

Mario's Manuals
Mario's Manuals
W9L10.2 W9U7912



VT750C2 SHADOW SPIRIT
2007 to 2009

GENERAL INFORMATION

SERVICE RULES

1. Use genuine Honda or Honda-recommended parts and lubricants or their equivalents. Parts that don't meet Honda's design specifications may cause damage to the motorcycle.
2. Use the special tools designed for this product to avoid damage and incorrect assembly.
3. Use only metric tools when servicing the motorcycle. Metric bolts, nuts and screws are not interchangeable with English fasteners.
4. Install new gaskets, O-rings, cotter pins, and lock plates when reassembling.
5. When tightening bolts or nuts, begin with the larger diameter or inner bolt first. Then tighten to the specified torque diagonally in incremental steps unless a particular sequence is specified.
6. Clean parts in cleaning solvent upon disassembly. Lubricate any sliding surfaces before reassembly.
7. After reassembly, check all parts for proper installation and operation.
8. Route all electrical wires as shown in the Cable and Harness Routing (page 1-22).

ABBREVIATION

Throughout this manual, the following abbreviations are used to identify the respective parts or systems.

Abbrev. term	Full term
SE valve	Starting Enrichment valve
TP sensor	Throttle Position sensor
EOP switch	Engine Oil Pressure switch
VS sensor	Vehicle Speed sensor
ICM	Ignition Control Module
CAV control valve	Carburetor Air Vent control valve
PAIR	Pulsed Secondary Air Injection
EVAP	Evaporative Emission
ECT sensor	Engine Coolant Temperature sensor

MODEL IDENTIFICATION

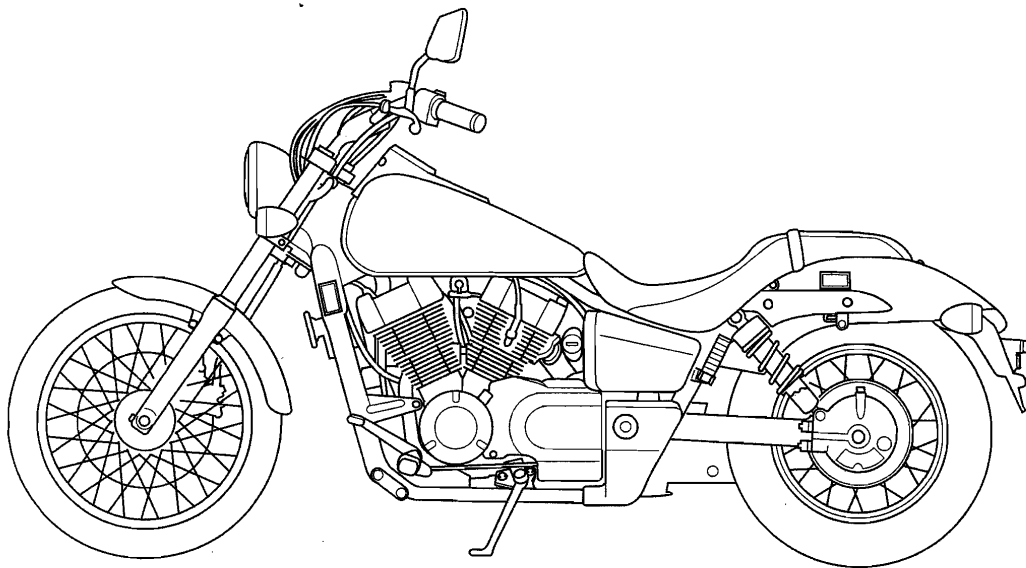

SERIAL NUMBERS

The Vehicle Identification Number (VIN) is stamped on the right side of the steering head.

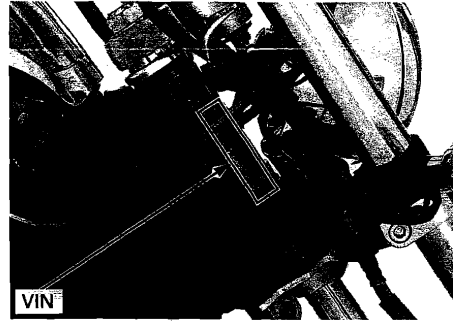

The engine serial number is stamped on the right side of the crankcase.

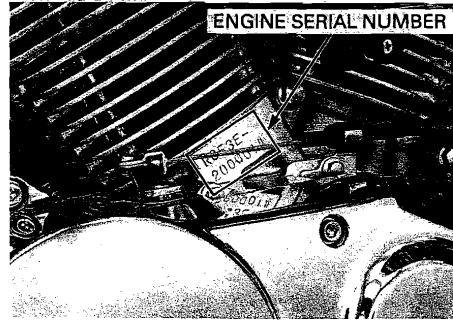

The carburetor identification number is stamped on the throttle position sensor side of the carburetor body.

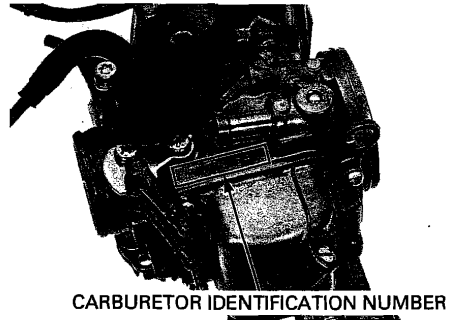

LABELS

The Safety Certification Label is located on the right side of the frame down tube.

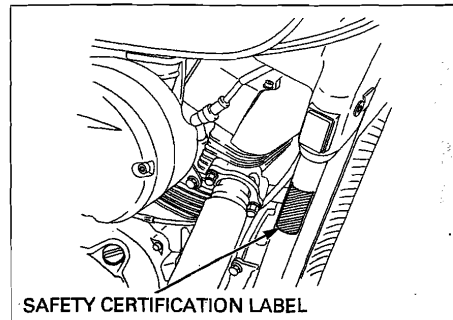

GENERAL INFORMATION

The color label is attached to the frame, behind of the left side cover. When ordering color-coded parts, always specify the designated color code.



The Emission Control Information Label ('07 model) is located on the rear fender and frame cross pipe as shown.

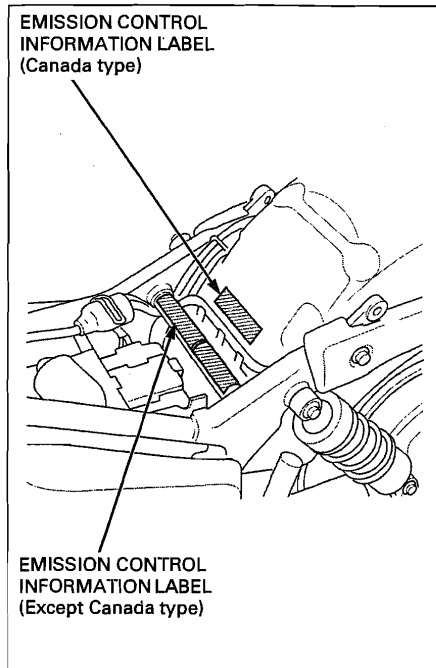

The Emission Control Information Label (After '07) is located on the left side of the frame down tube.

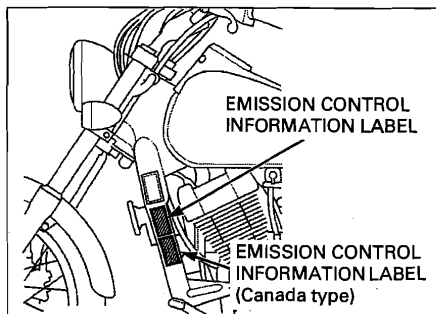

NEW

GENERAL SPECIFICATIONS

ITEM		SPECIFICATIONS
DIMENSION	Overall length Overall width Overall height Wheelbase Seat height Footpeg height Ground clearance Curb weight (49 states/Canada type) (California type) Maximum weight capacity (49 states/California type) (Canada type)	2,430 mm (95.7 in) 835 mm (32.9 in) 1,130 mm (44.5 in) 1,655 mm (65.2 in) 655 mm (25.8 in) 283 mm (11.1 in) 130 mm (5.1 in) 243 kg (536 lbs) 246 kg (542 lbs) 180 kg (397 lbs) 184 kg (406 lbs)
FRAME	Frame type Front suspension Front axle travel Rear suspension Rear axle travel Front tire size Rear tire size Tire brand Front Rear Front brake Rear brake Caster angle Trail length Fuel tank capacity	Double cradle Telescopic fork 115 mm (4.5 in) Swingarm 90 mm (3.5 in) 90/90-21M/C 54S 160/80-15M/C 74S EXEDRA G701 (BRIDGESTONE) D404F (DUNLOP) EXEDRA G702 (BRIDGESTONE) D404 (DUNLOP) Hydraulic single disc Internal expanding shoe 34° 30' 158 mm (6.2 in) 14 liters (3.7 US gal, 3.1 Imp gal)
ENGINE	Cylinder arrangement Bore and stroke Displacement Compression ratio Valve train Intake valve opens closes Exhaust valve opens closes Lubrication system Oil pump type Cooling system Air filtration Engine dry weight Firing order Cylinder number	2 cylinders 52° V transverse 79 x 76 mm (3.1 x 3.0 in) 745 cm ³ (45.4 cu-in) 9.6 : 1 Silent cam chain driven, OHC Front: 0° BTDC (at 1 mm lift) Rear: 5° ATDC (at 1 mm lift) 25° ABDC (at 1 mm lift) 35° BBDC (at 1 mm lift) Front: 0° ATDC (at 1 mm lift) Rear: 5° BTDC (at 1 mm lift) Forced pressure and wet sump Trochoid Liquid cooled Viscous paper element 72.3 kg (159.4 lbs) Front - 308° - Rear - 412° - Front Front: #2/Rear: #1
CARBURETOR	Type Throttle bore	Constant velocity (CV) 34 mm (1.3 in)

GENERAL INFORMATION

	ITEM	SPECIFICATIONS
DRIVE TRAIN	Clutch system Clutch operation system Transmission Primary reduction Secondary reduction Third reduction (Output drive reduction) Final reduction Gear ratio 1st 2nd 3rd 4th 5th Gearshift pattern	Multi-plate, wet Cable operating Constant mesh, 5-speeds 1.763 (67/38) 0.891 (33/37) 1.058 (18/17) 3.091 (34/11) 2.400 (36/15) 1.550 (31/20) 1.174 (27/23) 0.960 (24/25) 0.852 (23/27) Left foot operated return system, 1 - N - 2 - 3 - 4 - 5
ELECTRICAL	Ignition system Starting system Charging system Regulator/rectifier Lighting system	Full transistorized ignition Electric starter motor Triple phase output alternator SCR shorted/triple phase full-wave rectification Battery

LUBRICATION SYSTEM SPECIFICATIONS

Unit: mm (in)

ITEM		STANDARD	SERVICE LIMIT
Engine oil capacity	At draining	2.5 liters (2.6 US qt, 2.2 Imp qt)	-
	At oil filter change	2.6 liters (2.7 US qt, 2.3 Imp qt)	-
	At disassembly	3.2 liters (3.4 US qt, 2.8 Imp qt)	-
Recommended engine oil		Pro Honda GN4 4-stroke oil (U.S.A. and Canada) or equivalent motor oil API service classification: SG or higher JASO T 903 standard: MA Viscosity: SAE 10W-30	-
Oil pressure at EOP switch		530 kPa (5.4 kgf/cm ² , 77 psi) at 5,000 rpm/(80°C/176°F)	-
Oil pump rotor	Tip clearance	0.15 (0.006)	0.20 (0.008)
	Body clearance	0.15 – 0.21 (0.006 – 0.008)	0.35 (0.014)
	Side clearance	0.02 – 0.08 (0.001 – 0.003)	0.10 (0.004)

FUEL SYSTEM SPECIFICATIONS

ITEM		SPECIFICATIONS
Carburetor identification number	49 states/Canada type	VE5EA
	California type	VE5EB
Main jet	Standard	#122
	High altitude	#120
Slow jet		#50
Pilot screw	Initial/final opening	See page 6-25
High altitude adjustment		See page 6-26
Float level		18.5 mm (0.73 in)
Engine idle speed		1,200 ± 100 rpm
Throttle grip freeplay		2 – 6 mm (1/16 – 1/4 in)

COOLING SYSTEM SPECIFICATIONS

ITEM		SPECIFICATIONS
Coolant capacity	Radiator and engine	1.58 liters (1.67 US qt, 1.39 Imp qt)
	Reserve tank	0.38 liter (0.40 US qt, 0.33 Imp qt)
Radiator cap relief pressure		108 – 137 kPa (1.1 – 1.4 kgf/cm ² , 16 – 20 psi)
Thermostat	Begin to open	80 – 84°C (176 – 183°F)
	Fully open	95°C (203°F)
	Valve lift	8 mm (0.3 in) minimum at 95°C (203°F)
Recommended antifreeze		Pro Honda HP Coolant or an equivalent high quality ethylene glycol antifreeze containing silicate-free corrosion inhibitors
Standard coolant concentration		1 : 1 (mixture with distilled water)

CYLINDER HEAD/VALVE SPECIFICATIONS

Unit: mm (in)

ITEM		STANDARD		SERVICE LIMIT
Cylinder compression at 400 rpm		1,373 ± 98 kPa (14.0 ± 1.0 kgf/cm ² , 199 ± 14 psi)		-
Valve clearance		IN	0.15 ± 0.02 (0.006 ± 0.001)	-
		EX	0.20 ± 0.02 (0.008 ± 0.001)	-
Cam chain tensioner wedge B length		-		6 (0.2)
Camshaft	Cam lobe height	IN	37.188 – 37.348 (1.4641 – 1.4704)	37.16 (1.463)
		EX	37.605 – 37.765 (1.4805 – 1.4868)	37.58 (1.480)
	Runout	IN/EX	-	0.05 (0.002)
	Journal O.D.	IN/EX	21.959 – 21.980 (0.8645 – 0.8654)	21.90 (0.862)
	Oil clearance	IN/EX	0.020 – 0.141 (0.0008 – 0.0056)	0.16 (0.006)
Rocker arm, rocker arm shaft	Rocker arm shaft O.D.	IN/EX	11.966 – 11.984 (0.4711 – 0.4718)	11.83 (0.466)
	Rocker arm I.D.	IN/EX	12.000 – 12.018 (0.4724 – 0.4731)	12.05 (0.474)
	Rocker arm-to-shaft clearance		0.016 – 0.052 (0.0006 – 0.0020)	0.07 (0.003)
Valve, valve guide	Valve stem O.D.	IN	5.475 – 5.490 (0.2156 – 0.2161)	5.45 (0.215)
		EX	5.455 – 5.470 (0.2148 – 0.2154)	5.41 (0.213)
	Valve guide I.D.	IN	5.500 – 5.510 (0.2165 – 0.2169)	5.56 (0.219)
		EX	5.500 – 5.512 (0.2165 – 0.2170)	5.56 (0.219)
	Stem-to-guide clearance	IN	0.010 – 0.035 (0.0004 – 0.0014)	0.10 (0.004)
		EX	0.030 – 0.057 (0.0012 – 0.0022)	0.11 (0.004)
	Valve guide projection above cylinder head	IN	18.7 – 18.9 (0.736 – 0.744)	-
		EX	17.2 – 17.4 (0.68 – 0.69)	-
Valve seat width	IN/EX	0.90 – 1.10 (0.035 – 0.043)	1.5 (0.06)	
Valve spring	Free length	IN	42.14 (1.659)	40.58 (1.598)
		EX	46.11 (1.815)	44.72 (1.761)
Cylinder head warpage		-		0.10 (0.004)

CYLINDER/PISTON SPECIFICATIONS

Unit: mm (in)

ITEM		STANDARD		SERVICE LIMIT	
Cylinder	I.D.	79.000 – 79.015 (3.1102 – 3.1108)		79.10 (3.114)	
	Out-of-round	-		0.06 (0.002)	
	Taper	-		0.06 (0.002)	
	Warpage	-		0.10 (0.004)	
Piston, piston pin, piston rings	Piston O.D. at 17 mm (0.7 in) from the bottom	78.97 – 78.99 (3.109 – 3.110)		78.90 (3.106)	
	Piston pin bore I.D.	18.002 – 18.008 (0.7087 – 0.7090)		18.05 (0.711)	
	Piston pin O.D.	17.994 – 18.000 (0.7084 – 0.7087)		17.98 (0.708)	
	Piston-to-piston pin clearance	0.002 – 0.014 (0.0001 – 0.0006)		0.04 (0.002)	
	Piston ring end gap	Top	0.15 – 0.25 (0.006 – 0.010)		0.4 (0.02)
		Second	0.25 – 0.40 (0.010 – 0.016)		0.6 (0.02)
		Oil (side rail)	0.20 – 0.80 (0.008 – 0.031)		1.0 (0.04)
	Piston ring-to-ring groove clearance	Top	0.025 – 0.055 (0.0010 – 0.0022)		0.08 (0.003)
Second		0.015 – 0.045 (0.0006 – 0.0018)		0.07 (0.003)	
Cylinder-to-piston clearance		0.010 – 0.045 (0.0004 – 0.0018)		0.10 (0.004)	
Connecting rod small end I.D.		18.016 – 18.034 (0.7093 – 0.7100)		18.07 (0.711)	
Connecting rod-to-piston pin clearance		0.016 – 0.040 (0.0006 – 0.0016)		0.06 (0.002)	

CLUTCH/GEARSHIFT LINKAGE SPECIFICATIONS

Unit: mm (in)

ITEM		STANDARD	SERVICE LIMIT
Clutch lever freeplay		10 – 20 (3/8 – 13/16)	–
Clutch	Spring free length	45.3 (1.78)	43.9 (1.73)
	Disc thickness	Disc A	2.62 – 2.78 (0.103 – 0.109)
		End disc	2.92 – 3.08 (0.115 – 0.121)
	Plate warpage	–	0.30 (0.012)
Clutch outer guide	I.D.	21.991 – 22.016 (0.8658 – 0.8668)	22.03 (0.867)
	O.D.	31.959 – 31.975 (1.2582 – 1.2589)	31.92 (1.257)
Mainshaft O.D. at clutch outer guide		21.967 – 21.980 (0.8648 – 0.8654)	21.95 (0.864)
Clutch outer guide-to-mainshaft clearance		0.011 – 0.049 (0.0004 – 0.0019)	0.08 (0.003)
Clutch outer I.D.		32.000 – 32.025 (1.2598 – 1.2608)	32.09 (1.263)
Clutch outer-to-outer guide clearance		0.025 – 0.066 (0.0010 – 0.0026)	0.18 (0.007)
Oil pump drive sprocket I.D.		32.025 – 32.145 (1.2608 – 1.2655)	32.16 (1.266)
Oil pump drive sprocket-to-clutch outer guide clearance		0.050 – 0.186 (0.0020 – 0.0073)	0.23 (0.009)

ALTERNATOR/STARTER CLUTCH SPECIFICATIONS

Unit: mm (in)

ITEM		STANDARD	SERVICE LIMIT
Starter driven gear	I.D.	37.000 – 37.025 (1.4567 – 1.4577)	37.10 (1.461)
	O.D.	57.749 – 57.768 (2.2736 – 2.2743)	57.73 (2.273)
Starter clutch outer I.D.		74.414 – 74.440 (2.9297 – 2.9307)	74.46 (2.931)

GENERAL INFORMATION

CRANKSHAFT/TRANSMISSION SPECIFICATIONS

Unit: mm (in)

ITEM		STANDARD	SERVICE LIMIT	
Crankshaft	Connecting rod big end side clearance	0.05 – 0.20 (0.002 – 0.008)	0.30 (0.012)	
	Crankpin bearing oil clearance	0.028 – 0.052 (0.0011 – 0.0020)	0.07 (0.003)	
	Main journal oil clearance	0.020 – 0.038 (0.0008 – 0.0015)	0.07 (0.003)	
	Crankshaft runout	–	0.03 (0.001)	
	Main journal O.D.	52.982 – 53.000 (2.0859 – 2.0866)	52.976 (2.0857)	
Main journal I.D.		58.010 – 58.022 (2.2839 – 2.2843)	58.070 (2.2862)	
Shift fork, fork shaft	I.D.	13.000 – 13.018 (0.5118 – 0.5125)	13.03 (0.513)	
	Claw thickness	5.93 – 6.00 (0.233 – 0.236)	5.6 (0.22)	
	Fork shaft O.D.	12.966 – 12.984 (0.5105 – 0.5112)	12.90 (0.508)	
Shift drum O.D. at left end		11.966 – 11.984 (0.4711 – 0.4718)	11.94 (0.470)	
Shift drum journal I.D.		12.000 – 12.018 (0.4724 – 0.4731)	12.05 (0.474)	
Shift drum-to-shift drum journal clearance		0.016 – 0.052 (0.0006 – 0.0020)	0.09 (0.035)	
Transmission	Gear I.D.	M3, M5	28.000 – 28.021 (1.1024 – 1.1032)	28.04 (1.104)
		C1, C4	31.000 – 31.025 (1.2205 – 1.2215)	31.05 (1.222)
		C2	24.000 – 24.021 (0.9449 – 0.9457)	24.04 (0.946)
	Gear busing O.D.	M3, M5	27.959 – 27.980 (1.1007 – 1.1016)	27.94 (1.100)
		C1, C4	30.950 – 30.975 (1.2185 – 1.2195)	30.93 (1.218)
		C2	23.959 – 23.980 (0.9433 – 0.9441)	23.94 (0.943)
	Gear-to-bushing clearance	M3, M5, C2	0.020 – 0.062 (0.0008 – 0.0024)	0.10 (0.004)
		C1, C4	0.025 – 0.075 (0.0010 – 0.0030)	0.11 (0.004)
	Gear bushing I.D.	M3	25.000 – 25.021 (0.9843 – 0.9851)	25.04 (0.986)
		C2	20.000 – 20.021 (0.7874 – 0.7882)	20.04 (0.789)
	Mainshaft O.D.	at M3 bushing	24.959 – 24.980 (0.9826 – 0.9835)	24.94 (0.982)
	Countershaft O.D.	at C2 bushing	19.980 – 19.993 (0.7866 – 0.7871)	19.96 (0.786)
	Bushing-to-shaft clearance	M3	0.020 – 0.062 (0.0008 – 0.0024)	0.10 (0.004)
		C2	0.007 – 0.041 (0.0003 – 0.0016)	0.07 (0.003)
	Output drive train	Output gear I.D.		24.000 – 24.021 (0.9449 – 0.9457)
Output gear bushing		O.D.	23.959 – 23.980 (0.9433 – 0.9441)	23.70 (0.933)
		I.D.	20.020 – 20.041 (0.7882 – 0.7890)	20.06 (0.790)
Output drive gear shaft O.D.		19.979 – 20.000 (0.7866 – 0.7874)	19.97 (0.786)	
Gear-to-bushing clearance		0.020 – 0.062 (0.0008 – 0.0024)	0.082 (0.0032)	
Gear bushing-to-shaft clearance		0.020 – 0.042 (0.0008 – 0.0017)	0.08 (0.003)	
Output gear damper spring free length		62.3 (2.45)	59 (2.3)	
Output drive gear backlash		0.08 – 0.23 (0.003 – 0.009)	0.40 (0.016)	
Backlash difference between measurements		–	0.10 (0.004)	

FINAL DRIVE SPECIFICATIONS

Unit: mm (in)

ITEM		STANDARD	SERVICE LIMIT
Recommended final drive oil		Hypoid gear oil, SAE #80	–
Final drive oil capacity	At draining	160 cm ³ (5.4 US oz, 5.6 Imp oz)	–
	At disassembly	170 cm ³ (5.7 US oz, 6.0 Imp oz)	–
Final drive gear backlash		0.05 – 0.15 (0.002 – 0.006)	0.30 (0.012)
Backlash difference between measurements		–	0.10 (0.004)
Ring gear-to-stop pin clearance		0.30 – 0.60 (0.012 – 0.024)	–
Final drive gear assembly pre-load		0.2 – 0.4 N·m (2 – 4 kgf·cm, 0.1 – 0.3 lbf·ft)	–

FRONT WHEEL/SUSPENSION/STEERING SPECIFICATIONS

Unit: mm (in)

ITEM		STANDARD	SERVICE LIMIT
Minimum tire tread depth		-	1.5 (0.06)
Cold tire pressure	Up to 90 kg (200 lbs) load	200 kPa (2.00 kgf/cm ² , 29 psi)	-
	Up to maximum weight capacity	200 kPa (2.00 kgf/cm ² , 29 psi)	-
Axle runout		-	0.2 (0.01)
Wheel rim runout	Radial	-	2.0 (0.08)
	Axial	-	2.0 (0.08)
Wheel balance weight		-	60 g max.
Fork	Spring free length	371.8 (14.64)	364.4 (14.35)
	Tube runout	-	0.2 (0.01)
	Recommended fork fluid	Pro Honda Suspension Fluid SS-8 (10W)	-
	Fluid level	100 (3.9)	-
	Fluid capacity	478 ± 2.5 cm ³ (16.2 ± 0.08 US oz, 16.8 ± 0.09 Imp oz)	-
Steering head bearing pre-load		8.5 – 12.7 N (0.9 – 1.3 kgf)	-

REAR WHEEL/BRAKE/SUSPENSION SPECIFICATIONS

Unit: mm (in)

ITEM		STANDARD	SERVICE LIMIT
Minimum tire tread depth		-	2.0 (0.08)
Cold tire pressure	Up to 90 kg (200 lbs) load	200 kPa (2.00 kgf/cm ² , 29 psi)	-
	Up to maximum weight capacity	250 kPa (2.50 kgf/cm ² , 36 psi)	-
Axle runout		-	0.2 (0.01)
Wheel rim runout	Radial	-	2.0 (0.08)
	Axial	-	2.0 (0.08)
Wheel balance weight		-	70 g max.
Brake drum I.D.		180.0 – 180.3 (7.09 – 7.10)	181 (7.1)
Brake pedal height		75 mm (3.0 in) above the top of the footpeg	-
Brake pedal freeplay		20 – 30 (13/16 – 1-3/16)	-
Shock absorber spring pre-load adjuster setting		2nd position	-

HYDRAULIC BRAKE SPECIFICATIONS

Unit: mm (in)

ITEM		STANDARD	SERVICE LIMIT
Recommended brake fluid		DOT 4	-
Front	Brake disc thickness	5.8 – 6.2 (0.23 – 0.24)	5.0 (0.20)
	Brake disc warpage	-	0.30 (0.012)
	Master cylinder I.D.	11.000 – 11.043 (0.4331 – 0.4348)	11.05 (0.435)
	Master piston O.D.	10.957 – 10.984 (0.4314 – 0.4324)	10.945 (0.4309)
	Caliper cylinder I.D.	27.000 – 27.050 (1.0630 – 1.0650)	27.060 (1.0654)
	Caliper piston O.D.	26.935 – 26.968 (1.0604 – 1.0617)	26.930 (1.0602)

GENERAL INFORMATION

BATTERY/CHARGING SYSTEM SPECIFICATIONS

ITEM		SPECIFICATIONS	
Battery	Capacity	12 V – 10 Ah or 12 V – 11 Ah	
	Current leakage	1 mA max.	
	Voltage (20°C/68°F)	Fully charged	13.0 – 13.2 V
		Needs charging	Below 12.4 V
	Charging current	Normal	1.1 A/5 – 10 h
Quick		5.5 A/1.0 h	
Alternator	Capacity	0.35 kW/5,000 rpm	
	Charging coil resistance (20°C/68°F)	0.1 – 1.0 Ω	

IGNITION SYSTEM SPECIFICATIONS

ITEM		SPECIFICATIONS
Spark plug	Standard	DPR6EA-9 (NGK), X20EPR-U9 (DENSO)
	For extended high speed riding	DPR7EA-9 (NGK), X22EPR-U9 (DENSO)
Spark plug gap		0.8 – 0.9 mm (0.03 – 0.04 in)
Ignition coil primary peak voltage		100 V minimum
Ignition pulse generator peak voltage		0.7 V minimum
Ignition timing ("F"mark)		13° BTDC at idle
TP sensor	Resistance (20°C/68°F)	4 – 6 kΩ
	Input voltage	5 V

ELECTRIC STARTER SPECIFICATIONS

ITEM	STANDARD	SERVICE LIMIT
Starter motor brush length	12.5 (0.49)	6.5 (0.26)

Unit: mm (in)

LIGHTS/METERS/SWITCHES SPECIFICATIONS

ITEM		SPECIFICATIONS
Bulbs	Headlight	12 V – 60/55 W
	Brake/taillight	12 V – 21/5 W
	License light	12 V – 5 W
	Front turn signal/position light	12 V – 21/5 W x 2
	Rear turn signal light	12 V – 21 W x 2
	Instrument light	LED x 6
	Turn signal indicator	LED
	High beam indicator	LED
	Neutral indicator	LED
	Oil pressure indicator	LED
	Coolant temperature indicator	LED
Fuse	Main fuse	30 A
	Sub fuse	10 A x 5, 20 A x 1
ECT sensor switch	Start to close (ON)	112 – 118°C (234 – 244°F)
	Stop to open (OFF)	108°C (226°F) minimum
Fan motor switch	Start to close (ON)	103 – 107°C (217 – 225°F)
	Stop to open (OFF)	94 – 98°C (201 – 208°F)

STANDARD TORQUE VALUES

FASTENER TYPE	TORQUE N-m (kgf-m, lbf-ft)	FASTENER TYPE	TORQUE N-m (kgf-m, lbf-ft)
5 mm bolt and nut	5.2 (0.5, 3.8)	5 mm screw	4.2 (0.4, 3.1)
6 mm bolt and nut	10 (1.0, 7)	6 mm screw	9 (0.9, 6.6)
8 mm bolt and nut	22 (2.2, 16)	6 mm flange bolt (8 mm head, small flange)	9 (0.9, 6.6)
10 mm bolt and nut	34 (3.5, 25)	6 mm flange bolt (8 mm head, large flange)	12 (1.2, 9)
12 mm bolt and nut	55 (5.6, 41)	6 mm flange bolt (10 mm head) and nut	12 (1.2, 9)
		8 mm flange bolt and nut	27 (2.8, 20)
		10 mm flange bolt and nut	39 (4.0, 29)

ENGINE & FRAME TORQUE VALUES

- Torque specifications listed below are for important fasteners.
- Others should be tightened to standard torque values listed above.

ENGINE**FRAME/BODY PANELS/EXHAUST SYSTEM**

ITEM	Q'TY	THREAD DIA. (mm)	TORQUE N-m (kgf-m, lbf-ft)	REMARKS
Left crankcase rear cover socket bolt	1	6	10 (1.0, 7)	
Exhaust pipe joint stud bolt	4	8	-	See page 3-11

MAINTENANCE

ITEM	Q'TY	THREAD DIA. (mm)	TORQUE N-m (kgf-m, lbf-ft)	REMARKS
Spark plug	4	12	18 (1.8, 13)	
Timing hole cap	1	14	10 (1.0, 7)	Apply grease to the threads
Crankshaft hole cap	1	30	15 (1.5, 11)	Apply grease to the threads
Valve adjusting screw lock nut	6	7	23 (2.3, 17)	Apply engine oil to the threads and seating surface
Engine oil filter cartridge	1	20	26 (2.7, 19)	Apply engine oil to the threads
Oil filter boss (crankcase side)	1	20	18 (1.8, 13)	Apply locking agent to the threads
Engine oil drain bolt	1	14	29 (3.0, 21)	
Alternator cover socket bolt	3	6	10 (1.0, 7)	

LUBRICATION SYSTEM

ITEM	Q'TY	THREAD DIA. (mm)	TORQUE N-m (kgf-m, lbf-ft)	REMARKS
EOP switch	1	PT 1/8	12 (1.2, 9)	Apply sealant to the threads
EOP switch terminal screw	1	4	1.9 (0.2, 1.4)	
Oil pump assembly bolt	3	6	13 (1.3, 10)	

GENERAL INFORMATION

FUEL SYSTEM

ITEM	Q'TY	THREAD DIA. (mm)	TORQUE		REMARKS
			N-m (kgf-m, lbf-ft)		
PAIR check valve cover bolt	4	5	7 (0.7, 5.2)		
Vacuum chamber cover screw	4	4	2.1 (0.2, 1.5)		
TP sensor torx screw	1	5	3.4 (0.3, 2.5)		
Carburetor heater set plate screw	2	5	3.4 (0.3, 2.5)		
Float chamber screw	4	4	2.1 (0.2, 1.5)		
Accelerator pump cover screw	3	4	2.1 (0.2, 1.5)		
Air cut-off valve cover screw	2	4	2.1 (0.2, 1.5)		
Accelerator pump link mounting bolt	1	5	3.4 (0.3, 2.5)		
Throttle cable stay mounting screw	2	5	3.4 (0.3, 2.5)		
SE valve nut	1	12	2.3 (0.2, 1.7)		
Carburetor drain screw	1	6	1.5 (0.2, 1.1)		
Slow jet	1	6	1.8 (0.2, 1.3)		
Needle jet holder	1	7	2.3 (0.2, 1.7)		
Main jet	1	5	2.1 (0.2, 1.5)		

COOLING SYSTEM

ITEM	Q'TY	THREAD DIA. (mm)	TORQUE		REMARKS
			N-m (kgf-m, lbf-ft)		
Water pump cover bolt	5	6	13 (1.3, 10)		

CYLINDER HEAD/VALVE

ITEM	Q'TY	THREAD DIA. (mm)	TORQUE		REMARKS
			N-m (kgf-m, lbf-ft)		
Cylinder head cover bolt	4	6	10 (1.0, 7)		
Cylinder head bolt	4	8	23 (2.3, 17)		Apply engine oil to the threads and seating surface
Cylinder head nut	8	10	47 (4.8, 35)		Apply engine oil to the threads and seating surface
Cam sprocket bolt	4	7	23 (2.3, 17)		Apply locking agent to the threads
Cam chain tensioner bolt	4	6	10 (1.0, 7)		See page 9-25
Camshaft holder bolt	6	8	23 (2.3, 17)		
Camshaft holder nut	4	8	23 (2.3, 17)		
Over head cover socket bolt	8	6	10 (1.0, 7)		

CYLINDER/PISTON

ITEM	Q'TY	THREAD DIA. (mm)	TORQUE		REMARKS
			N-m (kgf-m, lbf-ft)		
Cylinder stud bolt	2	8	-		See page 10-8
Cylinder stud bolt	6	10	-		See page 10-8
Cylinder stud bolt	2	12	-		See page 10-8

CLUTCH/GEARSHIFT LINKAGE

ITEM	Q'TY	THREAD DIA. (mm)	TORQUE		REMARKS
			N-m (kgf-m, lbf-ft)		
Clutch lifter plate bolt	4	6	12 (1.2, 9)		
Clutch center lock nut	1	18	128 (13.1, 94)		Lock nut; replace with a new one and stake
Oil pump driven sprocket bolt	1	6	15 (1.5, 11)		Apply engine oil to the threads and seating surface
Clutch cover socket bolt	5	6	10 (1.0, 7)		Apply locking agent to the threads
Primary drive gear bolt	1	12	88 (9.0, 65)		Apply engine oil to the threads and seating surface
Gearshift spindle return spring pin	1	8	23 (2.3, 17)		
Gearshift spindle oil seal stopper plate bolt	1	6	13 (1.3, 10)		

ALTERNATOR/STARTER CLUTCH

ITEM	Q'TY	THREAD DIA. (mm)	TORQUE N-m (kgf-m, lbf-ft)	REMARKS
Flywheel bolt	1	12	128 (13.1, 94)	Left hand threads Apply engine oil to the threads and seating surface
Stator socket bolt	3	6	12 (1.2, 9)	Apply locking agent to the threads
Starter one-way clutch outer socket bolt	6	8	30 (3.1, 22)	Apply locking agent to the threads
Stator wire holder socket bolt	1	6	12 (1.2, 9)	Apply locking agent to the threads

CRANKSHAFT/TRANSMISSION

ITEM	Q'TY	THREAD DIA. (mm)	TORQUE N-m (kgf-m, lbf-ft)	REMARKS
Crankcase bolt	15	8	23 (2.3, 17)	
Gearshift cam plate bolt	1	6	12 (1.2, 9)	Apply locking agent to the threads
Crankpin bearing cap nut	4	8	33 (3.4, 24)	Apply engine oil to the threads and seating surface
Output gear case mounting bolt	3	8	31 (3.2, 23)	Apply sealant to the threads
Output drive gear assembly mounting bolt	2	8	31 (3.2, 23)	Apply engine oil to the threads and seating surface
Output driven gear assembly mounting socket bolt	4	8	31 (3.2, 23)	Apply engine oil to the threads and seating surface
Output drive gear bearing lock nut (inner)	1	30	73 (7.4, 54)	Lock nut; replace with a new one and stake Apply engine oil to the threads and seating surface
(outer)	1	64	98 (10.0, 72)	Lock nut; replace with a new one and stake Apply engine oil to the threads and seating surface
Output driven gear bearing lock nut (inner)	1	30	73 (7.4, 54)	Lock nut; replace with a new one and stake Apply engine oil to the threads and seating surface
(outer)	1	64	98 (10.0, 72)	Lock nut; replace with a new one and stake Apply engine oil to the threads and seating surface
Output drive gear shaft bolt	1	10	49 (5.0, 36)	

ELECTRIC STARTER

ITEM	Q'TY	THREAD DIA. (mm)	TORQUE N-m (kgf-m, lbf-ft)	REMARKS
Starter motor cable terminal nut	1	6	10 (1.0, 7)	
Starter motor assembly bolt	2	5	4.9 (0.5, 3.6)	
Negative brush screw	1	5	3.7 (0.4, 2.7)	

LIGHTS/METERS/SWITCHES

ITEM	Q'TY	THREAD DIA. (mm)	TORQUE N-m (kgf-m, lbf-ft)	REMARKS
Neutral switch	1	10	12 (1.2, 9)	
VS sensor mounting bolt	1	6	9.8 (1.0, 7.2)	

GENERAL INFORMATION

FRAME

FRAME/BODY PANELS/EXHAUST SYSTEM

ITEM	Q'TY	THREAD DIA. (mm)	TORQUE N-m (kgf-m, lbf-ft)	REMARKS
Seat mounting socket bolt	2	8	26 (2.7, 19)	ALOC screw; replace with a new one
Grab rail mounting bolt	6	10	64 (6.5, 47)	
Fuel tank mounting bolt	1	8	27 (2.8, 20)	
Fuel valve nut	1	22	34 (3.5, 25)	
Fuel valve lever screw	1	5	0.6 (0.1, 0.4)	
Exhaust pipe joint nut	4	8	25 (2.5, 18)	
Muffler stay mounting bolt	4	8	27 (2.8, 20)	
Muffler mounting nut	2	10	44 (4.5, 32)	
Muffler bracket bolt	2	8	34 (3.5, 25)	

MAINTENANCE

ITEM	Q'TY	THREAD DIA. (mm)	TORQUE N-m (kgf-m, lbf-ft)	REMARKS
Air cleaner cover socket bolt	5	5	1.5 (0.2, 1.1)	
Final drive oil filler cap	1	30	12 (1.2, 9)	
Final drive oil drain bolt	1	8	12 (1.2, 9)	

FUEL SYSTEM

ITEM	Q'TY	THREAD DIA. (mm)	TORQUE N-m (kgf-m, lbf-ft)	REMARKS
Air cleaner chamber stay mounting screw	1	5	1.1 (0.1, 0.8)	
Air cleaner chamber connecting tube band screw	1	4	0.7 (0.1, 0.5)	

COOLING SYSTEM

ITEM	Q'TY	THREAD DIA. (mm)	TORQUE N-m (kgf-m, lbf-ft)	REMARKS
Fan motor mounting bolt	3	5	5.1 (0.5, 3.8)	Apply locking agent to the threads
Cooling fan mounting nut	1	5	2.7 (0.3, 2.0)	
Radiator filler mounting bolt	2	6	10 (1.0, 7)	See page 7-10
Thermostat housing cover bolt	2	6	10 (1.0, 7)	
Water hose band screw	6	-	-	
Fan motor assembly mounting bolt	3	6	8.4 (0.9, 6.2)	

ENGINE REMOVAL/INSTALLATION

ITEM	Q'TY	THREAD DIA. (mm)	TORQUE N-m (kgf-m, lbf-ft)	REMARKS
Engine mounting nut	4	10	54 (5.5, 40)	
Engine hanger plate bolt	8	8	26 (2.7, 19)	
Main footpeg bracket mounting bolt	3	10	39 (4.0, 29)	
Main footpeg bracket mounting nut	1	10	39 (4.0, 29)	
Gearshift arm pinch bolt	1	6	12 (1.2, 9)	

CLUTCH/GEARSHIFT LINKAGE

ITEM	Q'TY	THREAD DIA. (mm)	TORQUE N-m (kgf-m, lbf-ft)	REMARKS
Gearshift pedal pivot bolt	1	10	39 (4.0, 29)	

FINAL DRIVE

ITEM	Q'TY	THREAD DIA. (mm)	TORQUE N-m (kgf-m, lbf-ft)	REMARKS
Pinion retainer	1	64	108 (11.0, 80)	
Pinion retainer lock tab bolt	1	6	10 (1.0, 7)	
Pinion joint nut	1	16	108 (11.0, 80)	Apply locking agent to the threads
Dust guard plate bolt	1	6	10 (1.0, 7)	
Final gear case cover bolt	2	10	47 (4.8, 35)	Apply locking agent to the threads
Final gear case cover bolt	6	8	25 (2.5, 18)	
Final gear case assembly mounting nut	4	10	64 (6.5, 47)	
Final gear case stud bolt	4	10	-	See page 14-22
Rear shock absorber lower mounting bolt (left side)	1	8	22 (2.2, 16)	

FRONT WHEEL/SUSPENSION/STEERING

ITEM	Q'TY	THREAD DIA. (mm)	TORQUE N-m (kgf-m, lbf-ft)	REMARKS
Clutch lever pivot bolt	1	6	1 (0.1, 0.7)	
Clutch lever pivot nut	1	6	6 (0.6, 4.4)	
Handlebar upper holder bolt	4	8	23 (2.3, 17)	
Handlebar lower holder nut	2	8	23 (2.3, 17)	
Front brake disc bolt	6	8	42 (4.3, 31)	ALOC bolt; replace with a new one
Spoke	52	BC4	4.2 (0.4, 3.1)	
Front axle bolt	1	14	59 (6.0, 44)	
Front axle pinch bolt	2	8	22 (2.2, 16)	
Fork center socket bolt	2	10	29.5 (3.0, 22)	Apply locking agent to the threads
Fork cap	2	38	22.1 (2.3, 16)	
Tire valve nut	1	8V1	4 (0.4, 3.0)	
Fork top bridge pinch bolt	2	8	22 (2.2, 16)	
Fork bottom bridge pinch bolt	2	10	49 (5.0, 36)	
Steering top thread	1	26	-	See page 15-32
Steering top thread lock nut	1	26	-	See page 15-32
Steering stem nut	1	24	103 (10.5, 76)	

REAR WHEEL/BRAKE/SUSPENSION

ITEM	Q'TY	THREAD DIA. (mm)	TORQUE N-m (kgf-m, lbf-ft)	REMARKS
Spoke	52	BC4	4.2 (0.4, 3.1)	
Tire valve nut	1	8V1	4 (0.4, 3.0)	
Rear axle nut	1	18	88 (9.0, 65)	U-nut
Rear axle pinch bolt	1	8	27 (2.8, 20)	
Rear brake stopper arm nut	1	8	22 (2.2, 16)	
Rear brake arm pinch bolt	1	8	26 (2.7, 19)	
Rear shock absorber upper mounting bolt	2	8	26 (2.7, 19)	
Rear shock absorber lower mounting bolt (right side)	1	10	34 (3.5, 25)	
Stopper plate bolt	5	6	20 (2.0, 15)	ALOC bolt; replace with a new one
Swingarm left pivot bolt	1	30	103 (10.5, 76)	
Swingarm right pivot bolt	1	30	-	See page 16-26
Swingarm right pivot bolt lock nut	1	30	103 (10.5, 76)	

GENERAL INFORMATION

HYDRAULIC BRAKE

ITEM	Q'TY	THREAD DIA. (mm)	TORQUE N-m (kgf-m, lbf-ft)	REMARKS
Brake caliper bleed valve	1	8	5.5 (0.6, 4.1)	
Front master cylinder reservoir cap screw	2	4	1.5 (0.2, 1.1)	
Brake pad pin	1	10	18 (1.8, 13)	
Brake pad pin plug	1	10	2.5 (0.3, 1.8)	
Brake hose oil bolt	2	10	34 (3.5, 25)	
Brake lever pivot bolt	1	6	1 (0.1, 0.7)	
Brake lever pivot nut	1	6	6 (0.6, 4.4)	
Front brake light switch screw	1	4	1.2 (0.1, 0.9)	
Front master cylinder holder bolt	2	6	12 (1.2, 9)	
Front brake caliper bracket pin	1	8	12 (1.2, 9)	Apply locking agent to the threads
Front brake caliper pin	1	8	27 (2.8, 20)	Apply locking agent to the threads
Front brake caliper mounting bolt	2	8	30 (3.1, 22)	ALOC bolt; replace with a new one

BATTERY/CHARGING SYSTEM

ITEM	Q'TY	THREAD DIA. (mm)	TORQUE N-m (kgf-m, lbf-ft)	REMARKS
Battery case cover screw	1	6	1 (0.1, 0.7)	

LIGHTS/METERS/SWITCHES

ITEM	Q'TY	THREAD DIA. (mm)	TORQUE N-m (kgf-m, lbf-ft)	REMARKS
Headlight unit mounting bolt	2	5	4.1 (0.4, 3.0)	
Brake/tail light mounting nut	3	6	6.3 (0.6, 4.6)	
Speedometer mounting socket bolt	2	6	10 (1.0, 7)	
Ignition switch mounting bolt	2	6	12 (1.2, 9)	
Ignition switch cover screw	1	4	1 (0.1, 0.7)	
Fan motor switch	1	16	18 (1.8, 13)	
Sidestand switch bolt	1	6	10 (1.0, 7)	ALOC bolt; replace with a new one
ECT sensor switch	1	PT 1/8	7 (0.7, 5.2)	Apply sealant to the threads
Horn mounting bolt	1	8	21 (2.1, 15)	

OTHERS

ITEM	Q'TY	THREAD DIA. (mm)	TORQUE N-m (kgf-m, lbf-ft)	REMARKS
Sidestand pivot bolt	1	10	9 (0.9, 6.6)	Apply grease to the sliding surface
Sidestand pivot lock nut	1	10	30 (3.1, 22)	
Sidestand bracket bolt	2	10	49 (5.0, 36)	
Tool box screw	2	4	2 (0.2, 1.5)	

LUBRICATION & SEAL POINTS**ENGINE**

MATERIAL	LOCATION	REMARKS
Molybdenum disulfide oil (a mixture of 1/2 engine oil and 1/2 molybdenum disulfide grease)	Camshaft lobes and journal surface Valve stem (valve guide sliding surface) Rocker arm slipper surface Rocker arm shaft outer surface Crankpin bearing thrust surface Crankshaft main journals Clutch outer guide outer surface Transmission gear shift fork groove Transmission bushing sliding surface Connecting rod small end inner surface	
Engine oil	Piston outer surface Piston ring outer surface Piston pin outer surface Primary drive gear bolt threads and seating surface Flywheel bolt threads and seating surface Starter one-way clutch sprag Starter idle and reduction gear shaft outer surface Clutch center lock nut threads and seating surface Clutch lifter arm sliding surface of the right crankcase cover Clutch lifter arm sliding surface and slit Clutch discs and plates Cylinder wall Cylinder stud bolt threads Valve adjusting screw lock nut threads and seating surface Shift fork shaft whole surface Crankpin bearing cap nut threads and seating surface Output drive gear assembly mounting bolt threads and seating surface Output driven gear assembly mounting socket bolt threads and seating surface Output drive gear bearing lock nut (inner/outer) threads and seating surface Output driven gear bearing lock nut (inner/outer) threads and seating surface Cylinder head bolt/nut threads and seating surface Transmission gear tooth Engine oil filter cartridge threads Crankshaft main journal bearing surface Oil pipe seal Each bearings rotating area Each O-rings	
Multi-purpose grease	Crankshaft hole cap threads Timing hole cap threads Each oil seal lips	
Sealant	EOP switch threads Right and left crankcase mating surface Right crankcase cover mating surface Left crankcase cover mating surface Output gear case mounting bolt threads	Do not apply to the sealant to the head 3 – 4 mm (0.1 – 0.2 in)

GENERAL INFORMATION

MATERIAL	LOCATION	REMARKS
Locking agent	Cam sprocket bolt threads Starter one-way clutch outer socket bolt threads Oil pump driven sprocket bolt threads Final gear case stud bolt threads (gear case side) Stator wire holder socket bolt threads Gearshift cam plate bolt threads Transmission bearing setting plate bolt threads Cam chain tensioner setting plate bolt threads Stator socket bolt threads Oil filter boss crankcase side threads Left crankcase cover bolt threads (marked "△")	Coating width: 6.5 ± 1 mm (0.26 ± 0.04 in) Coating width: 6.5 ± 1 mm (0.26 ± 0.04 in) Coating width: 6.5 ± 1 mm (0.26 ± 0.04 in) Coating width: 6.5 ± 1 mm (0.26 ± 0.04 in) Coating width: 6.5 ± 1 mm (0.26 ± 0.04 in) Coating width: 6.5 ± 1 mm (0.26 ± 0.04 in)
Pro Honda Hondabond HT or equivalent	Cylinder head cover-to-gasket groove	

FRAME

MATERIAL	LOCATION	REMARKS
Sealant	Final gear case cover mating surface ECT sensor switch threads	Do not apply to the thread head
Multi-purpose grease	Sidestand pivot Main step sliding area Pillion step sliding area Throttle pipe flange groove and sliding surface Clutch lever pivot bolt sliding surface Gearshift spindle oil seal lips Gear shift pedal dust seal lips Front axle sliding surface Shock absorber mount inner surface Rear brake middle rod joint pivot and dust seal lips Rear brake cam sliding surface Brake shoe-to-anchor pin sliding surface Brake pedal pivot sliding surface Brake pedal dust seal lips Rear brake joint pins Front wheel dust seal lips Final gear case O-ring Final gear case oil seal lips	Apply 1 g Spreading 0.2 – 0.3 g Spreading 0.5 – 1.0 g Spreading 0.5 – 1.0 g
Urea based multi-purpose grease with extreme pressure (example: EXCELITE EP2 manufactured by KYODO YUSHI, Japan) or equivalent	Steering head bearings Steering head bearing dust seal lips Swingarm pivot bearing needle rollers Swingarm pivot dust seal lips	Apply 3 – 5 g for each bearing Apply 1.0 – 1.5 g for each bearing
Molybdenum disulfide grease	Output drive gear and damper cam splines Final drive shaft oil seal lip Final drive shaft splines (universal joint side) Final drive pinion joint splines	Apply 1 g Apply 0.5 g Apply 1 g Apply 2 g
Molybdenum disulfide paste	Final driven flange (rear wheel hub mating surface) Final driven flange O-ring Final gear case O-ring guide and driven flange joint surface Thrust washer and rear wheel hub end (final driven flange side)	Apply 0.5 – 1.0 g Apply 4 – 5 g Apply 2 – 3 g
Cable lubricant	Throttle cable outer inside Clutch cable outer inside Choke cable outer inside	
Pro Honda Handgrip Cement or equivalent	Handlebar grip inside Handlebar and throttle pipe outer surface (grip rubber contacting area)	
Engine oil	Steering top threads Rear brake cam felt seal	
Silicone grease	Brake lever pivot bolt sliding surface Brake lever-to-master piston contacting area Brake caliper and bracket pin boot inside Brake caliper dust seal	Apply 0.1 g Apply 0.1 g Apply 0.4 g
DOT 4 brake fluid	Brake master piston and cups Brake caliper piston and piston seals	
Pro Honda Suspension Fluid SS-8 (10W)	Fork dust seal and oil seal lips Fork cap O-ring	
Locking agent	Pinion joint nut threads Final gear case cover 10 mm bolt threads Fork center socket bolt threads Front brake caliper bracket pin threads Front brake caliper pin threads Final gear case stud bolt threads Steering stem cover bolt threads Cooling fan mounting nut threads	

GENERAL INFORMATION

CABLE & HARNESS ROUTING

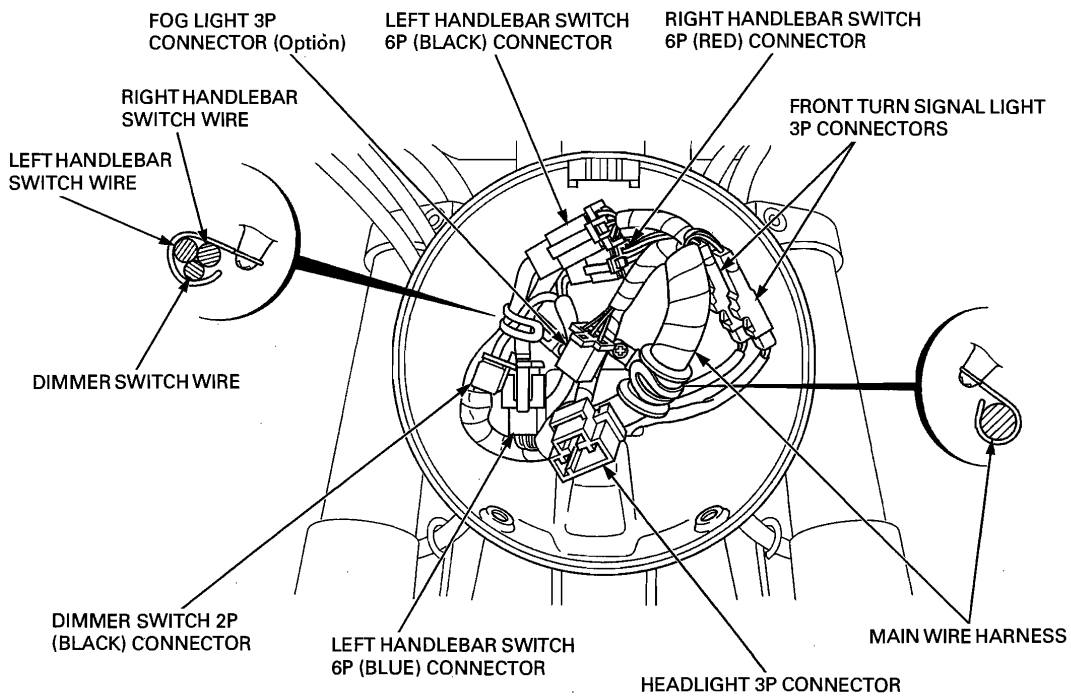
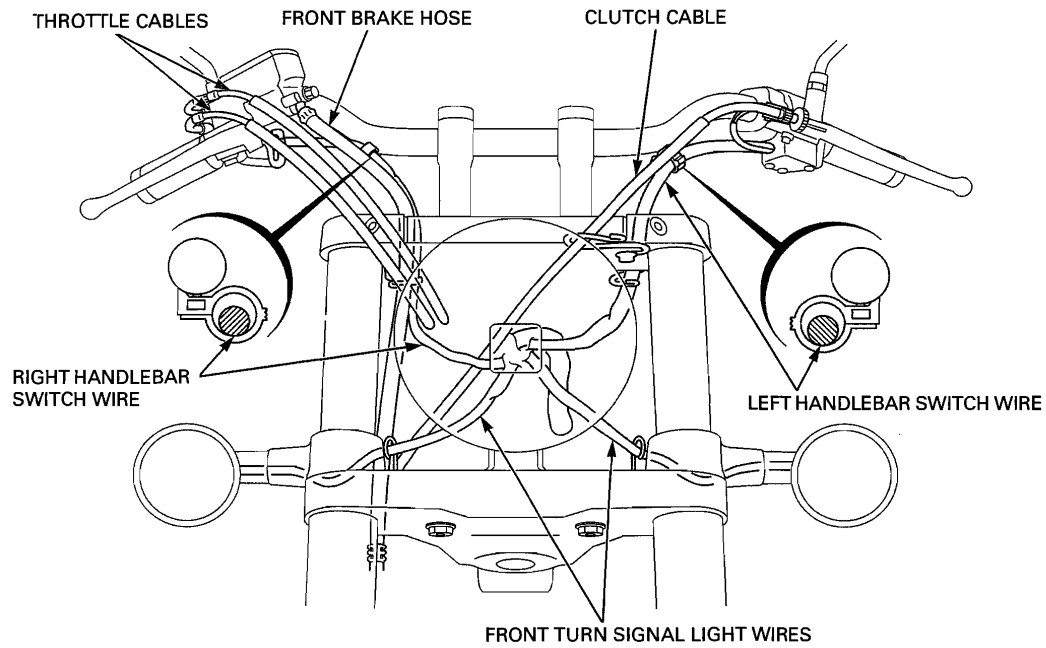

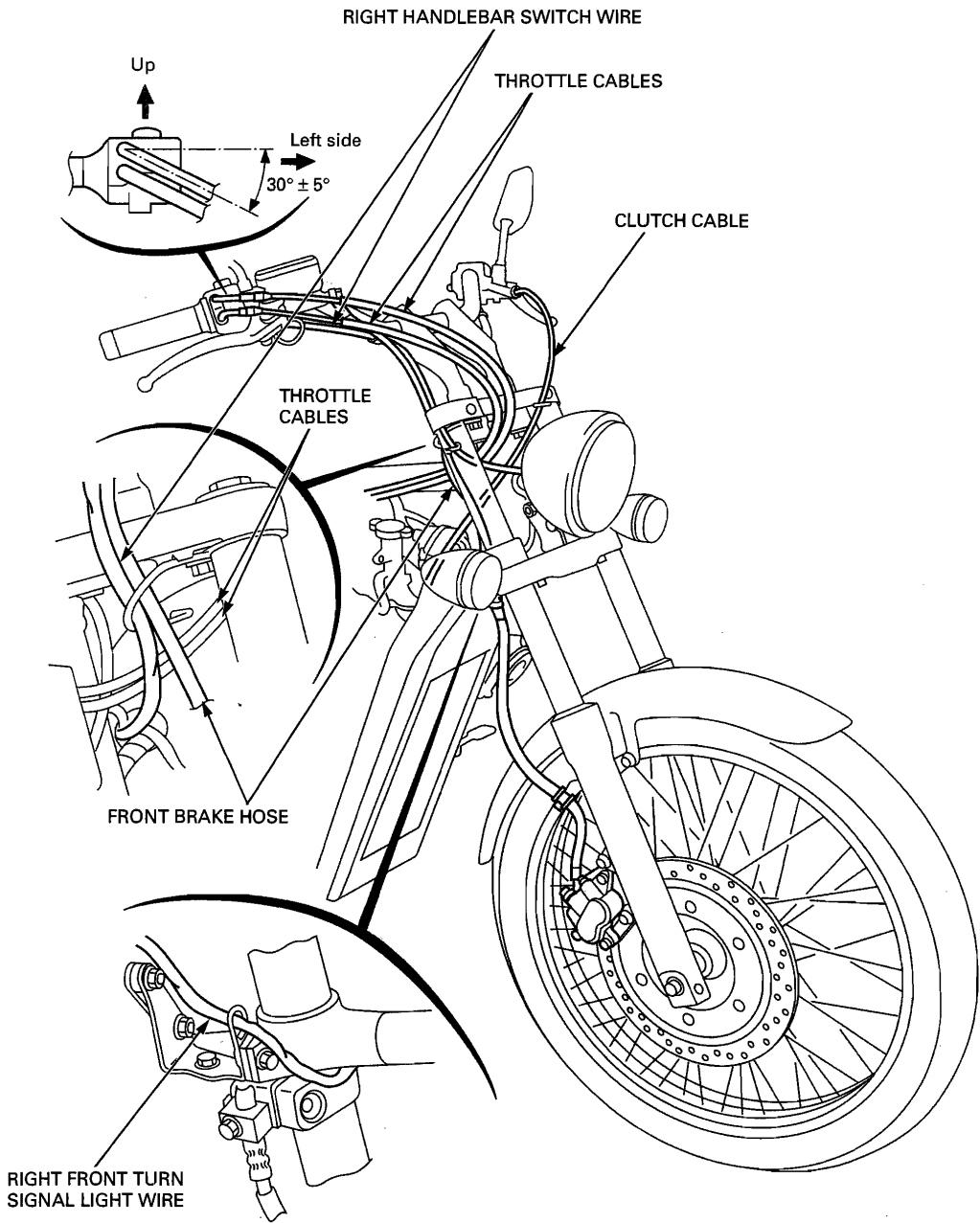

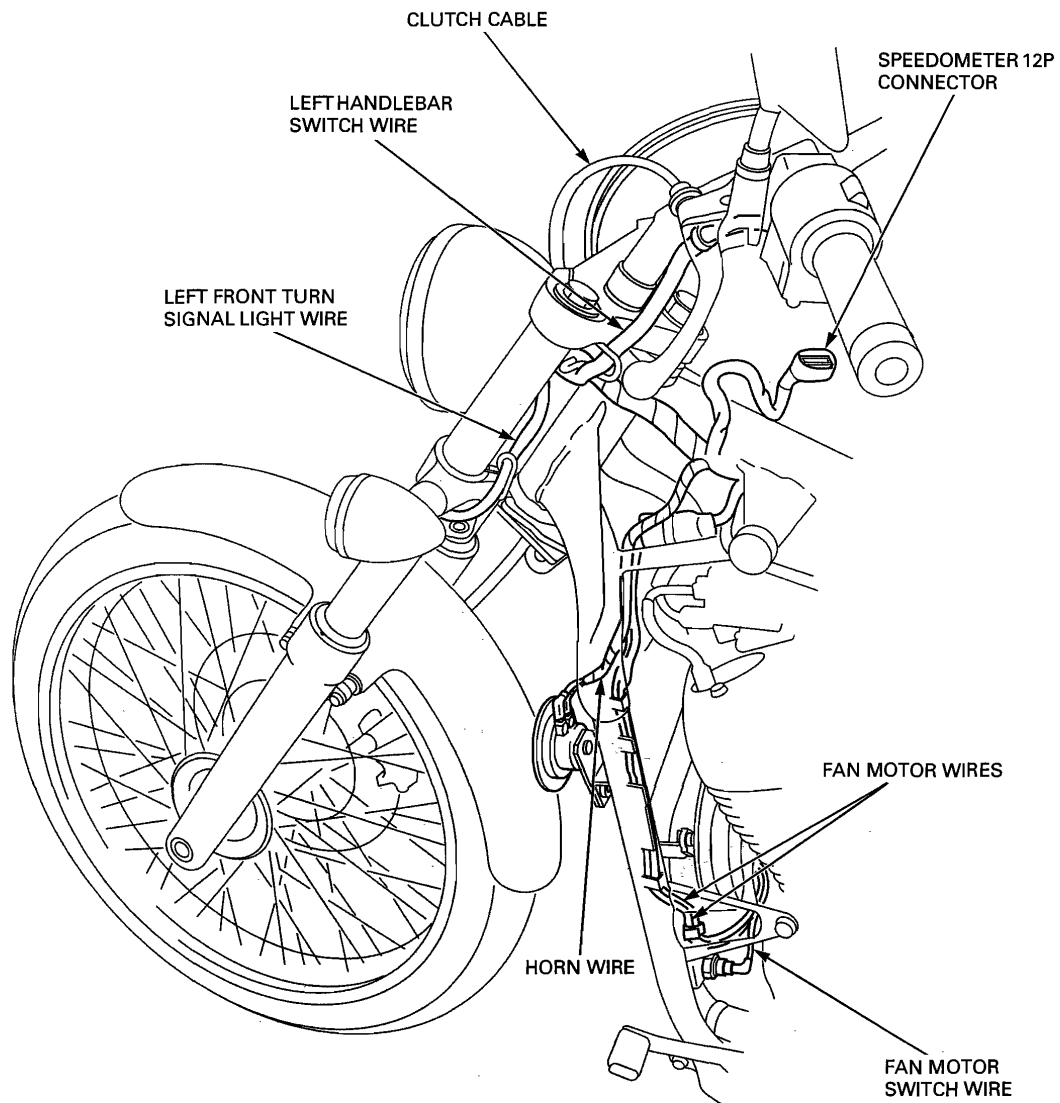

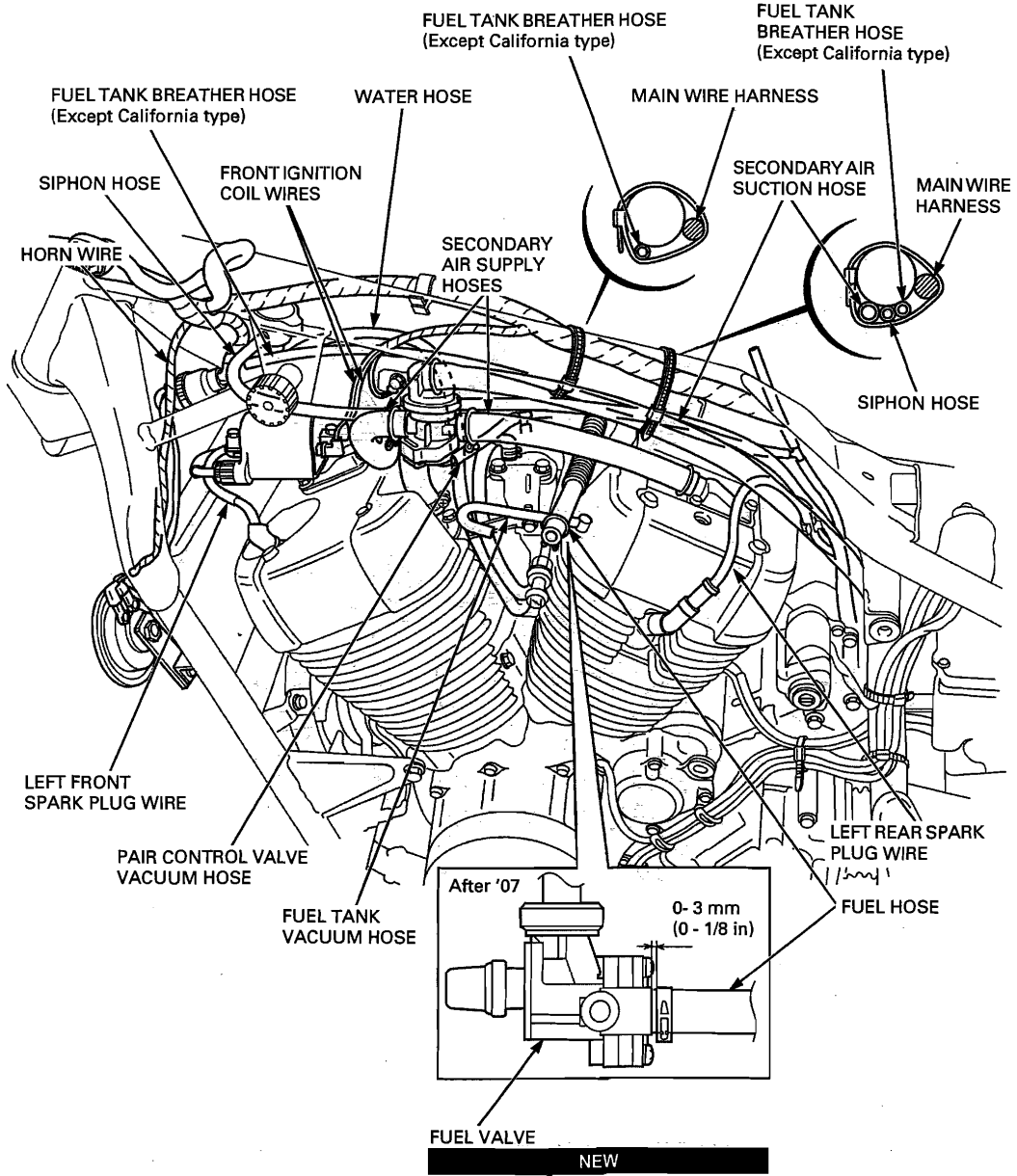

GENERAL INFORMATION

- (1) SIDESTAND SWITCH WIRE
- (2) GROUND CABLE
- (3) STARTER MOTOR CABLE
- (4) ALTERNATOR WIRE
- (5) NEUTRAL/OIL PRESSURE SWITCH WIRE
- (6) VS SENSOR WIRE
- (7) IGNITION SWITCH WIRE

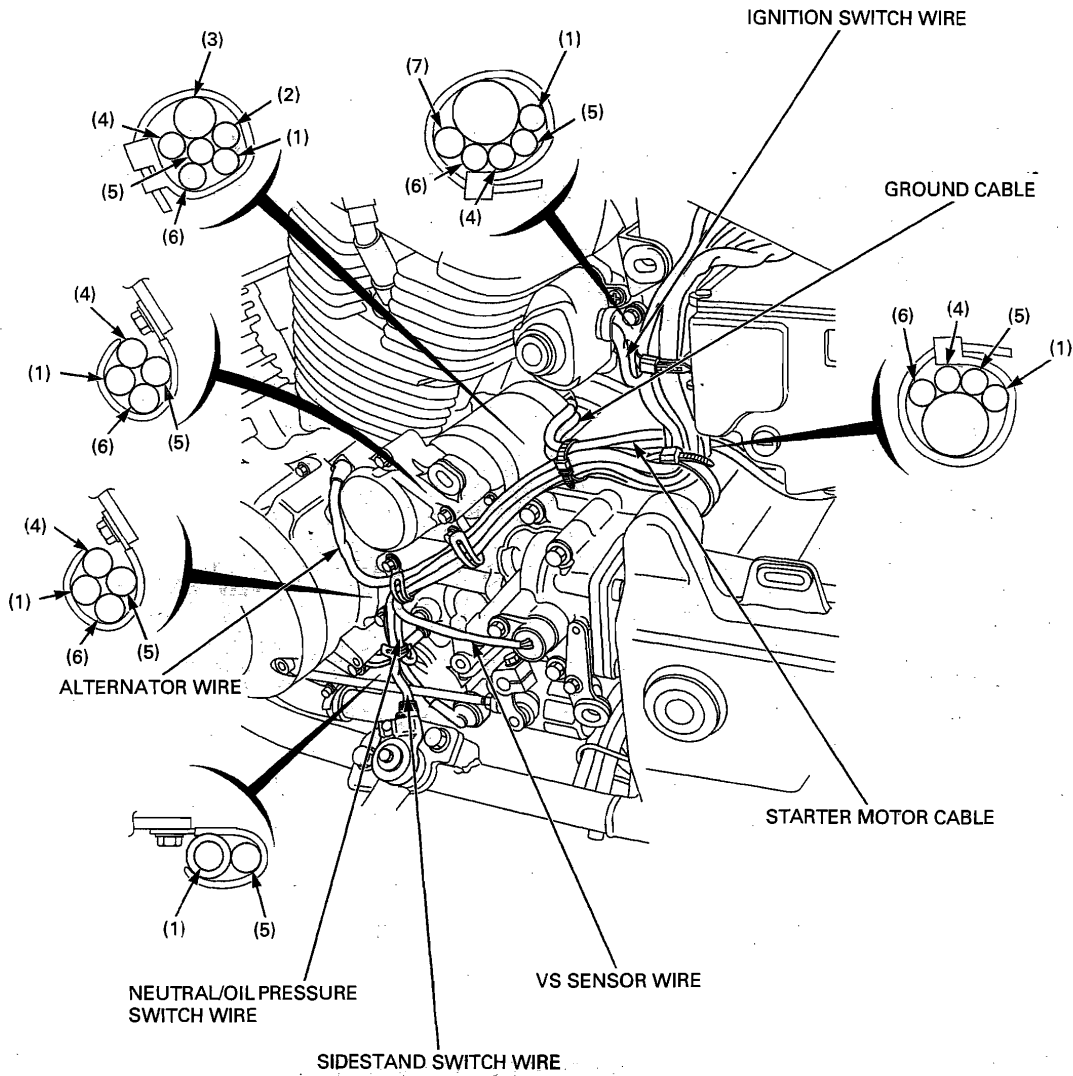

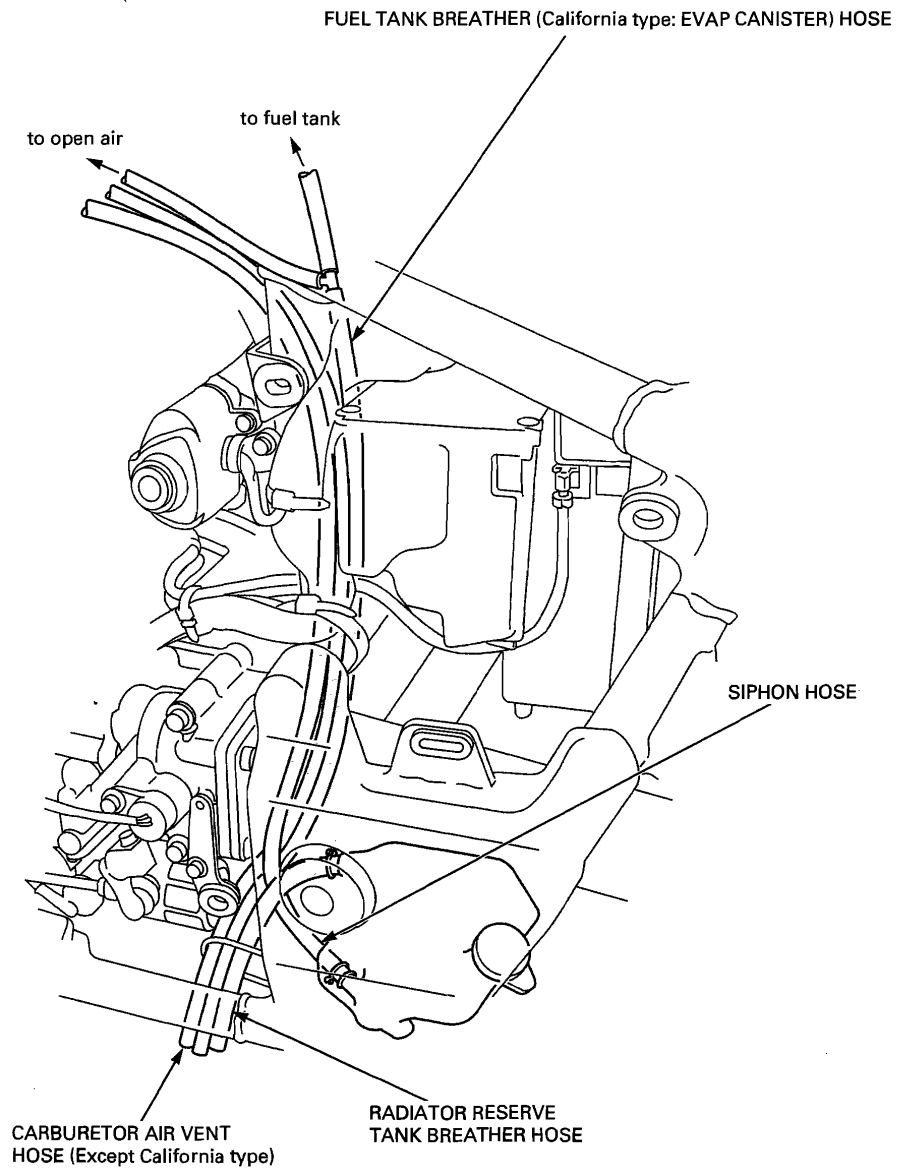

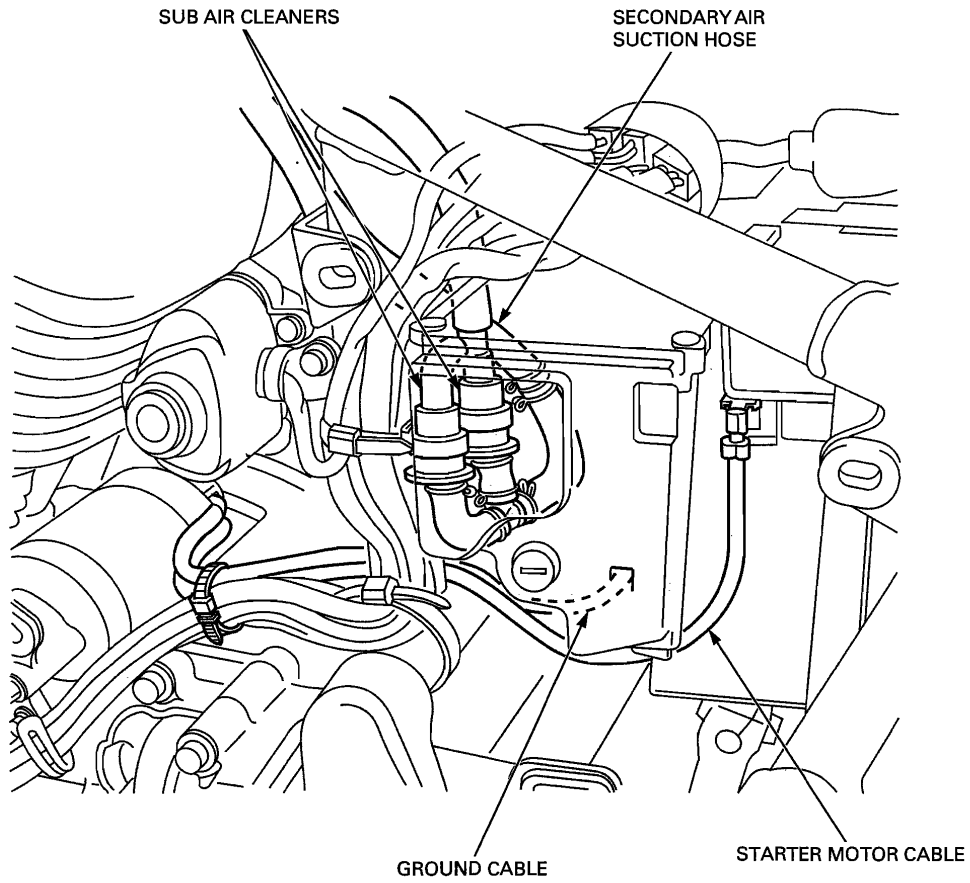

INSIDE BOOT CONNECTORS:

- IGNITION PULSE GENERATOR 2P (RED) CONNECTOR
- FAN MOTOR 2P (NATURAL) CONNECTOR
- REAR BRAKE LIGHT SWITCH 3P (LIGHT GRAY) CONNECTOR

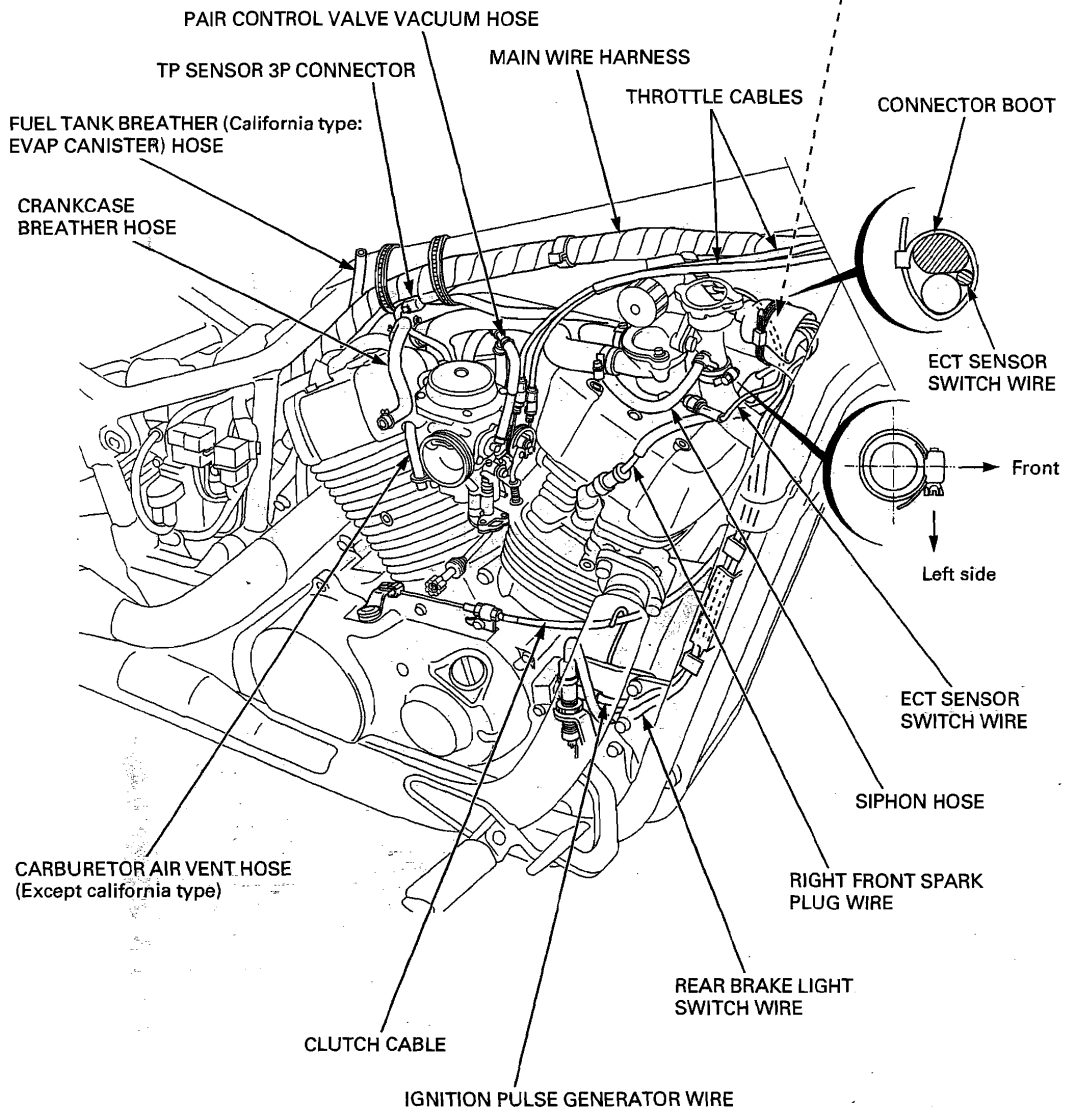

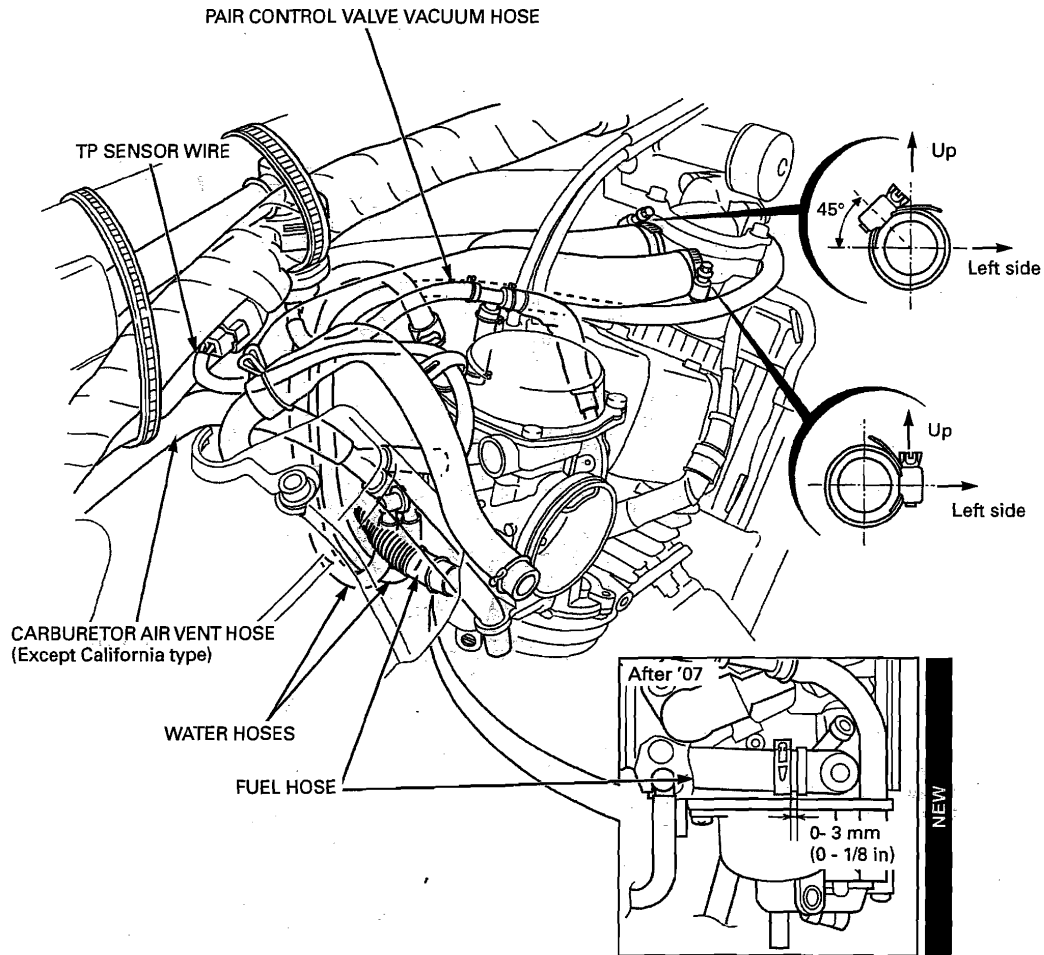

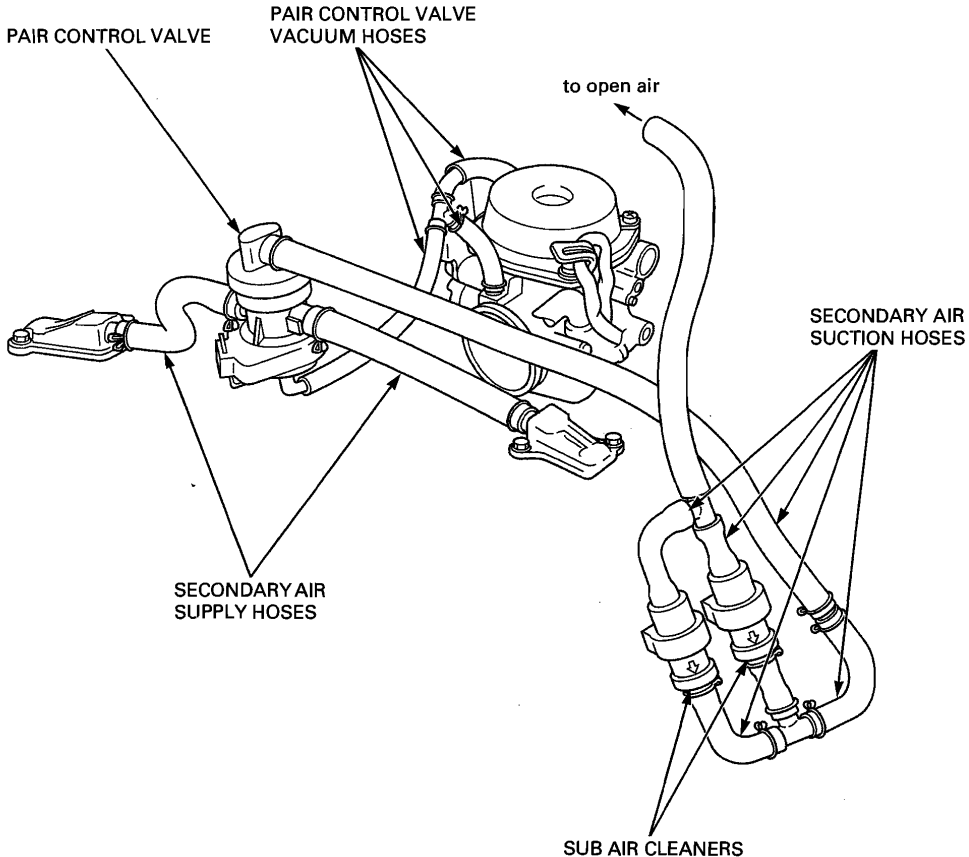

GENERAL INFORMATION

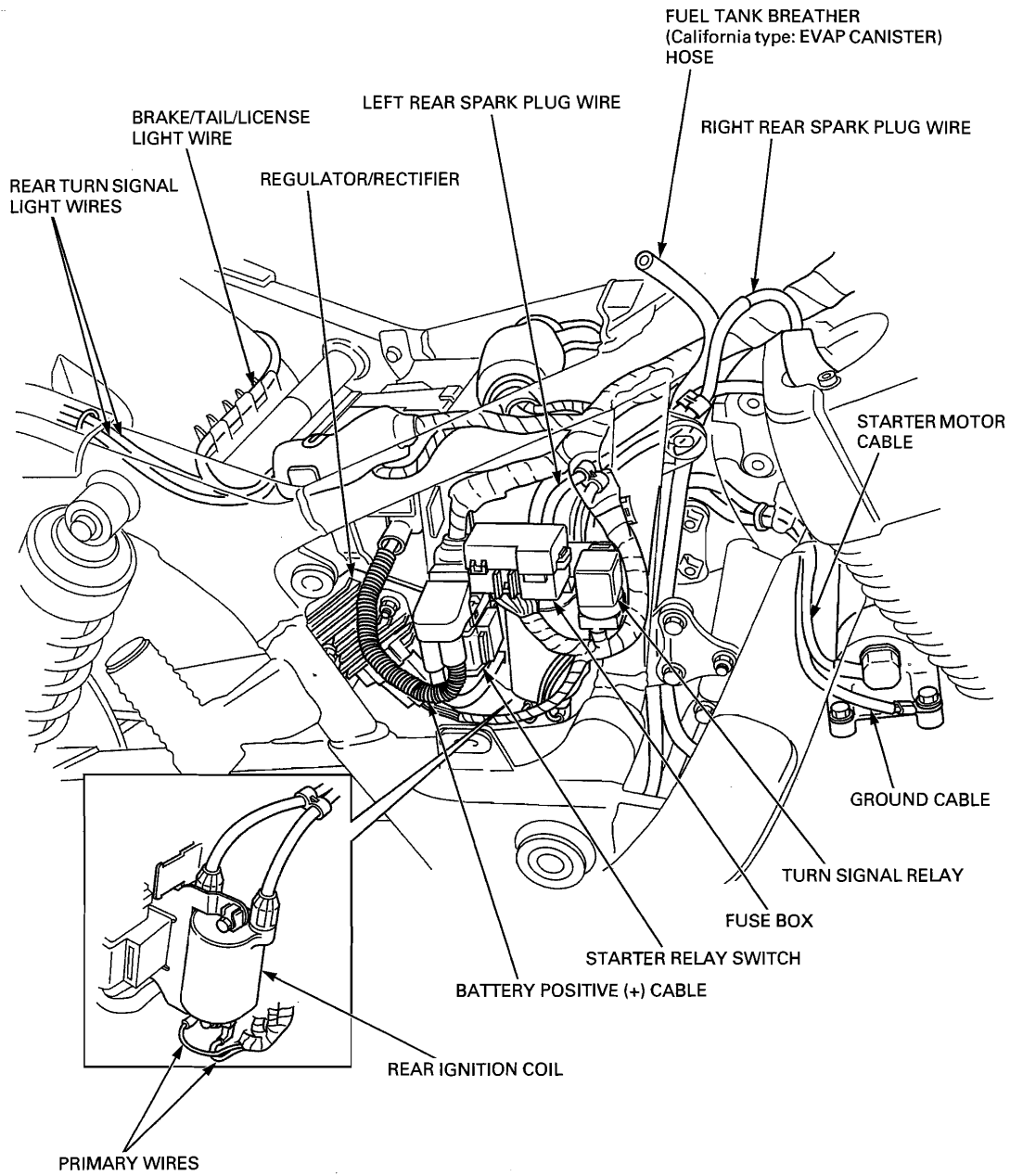

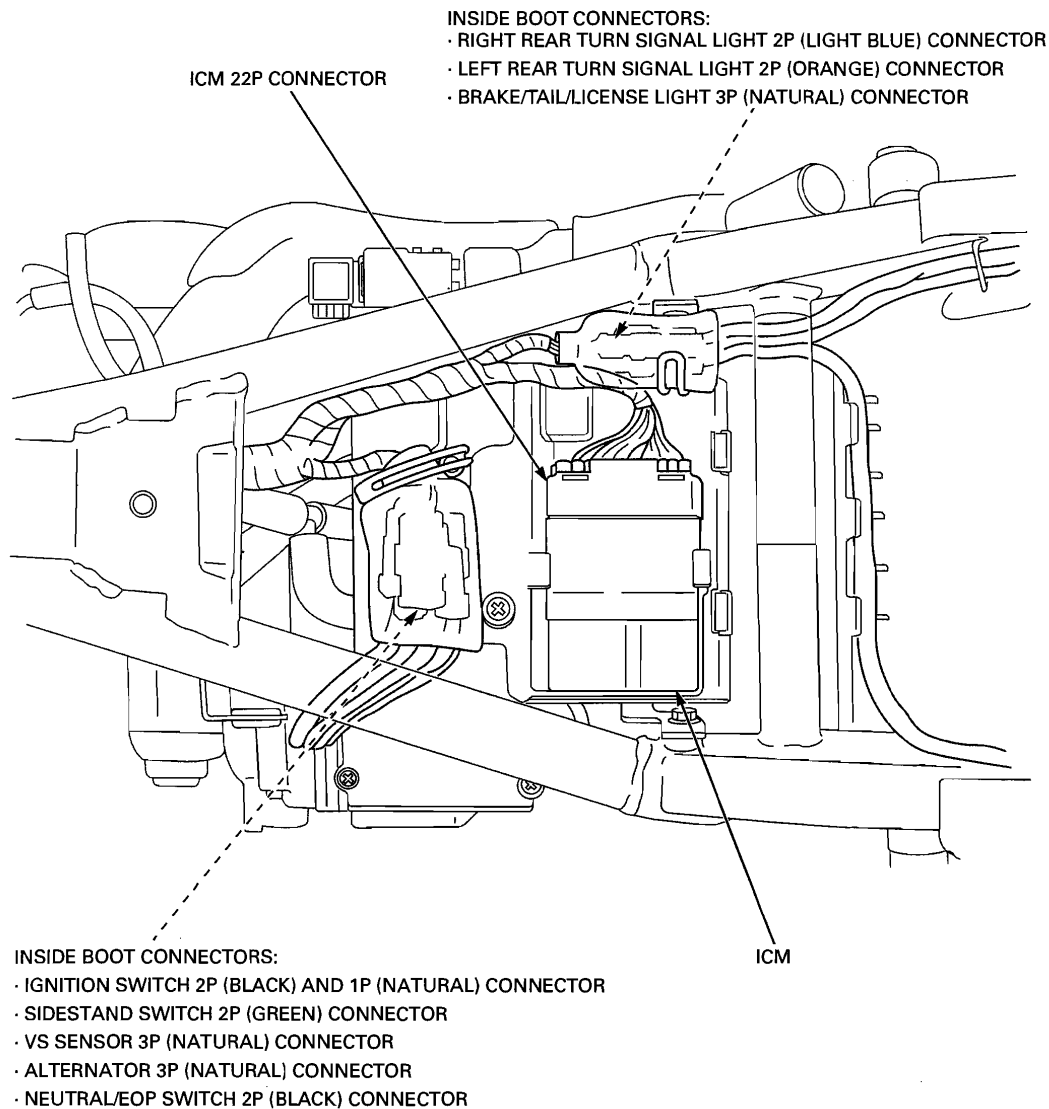

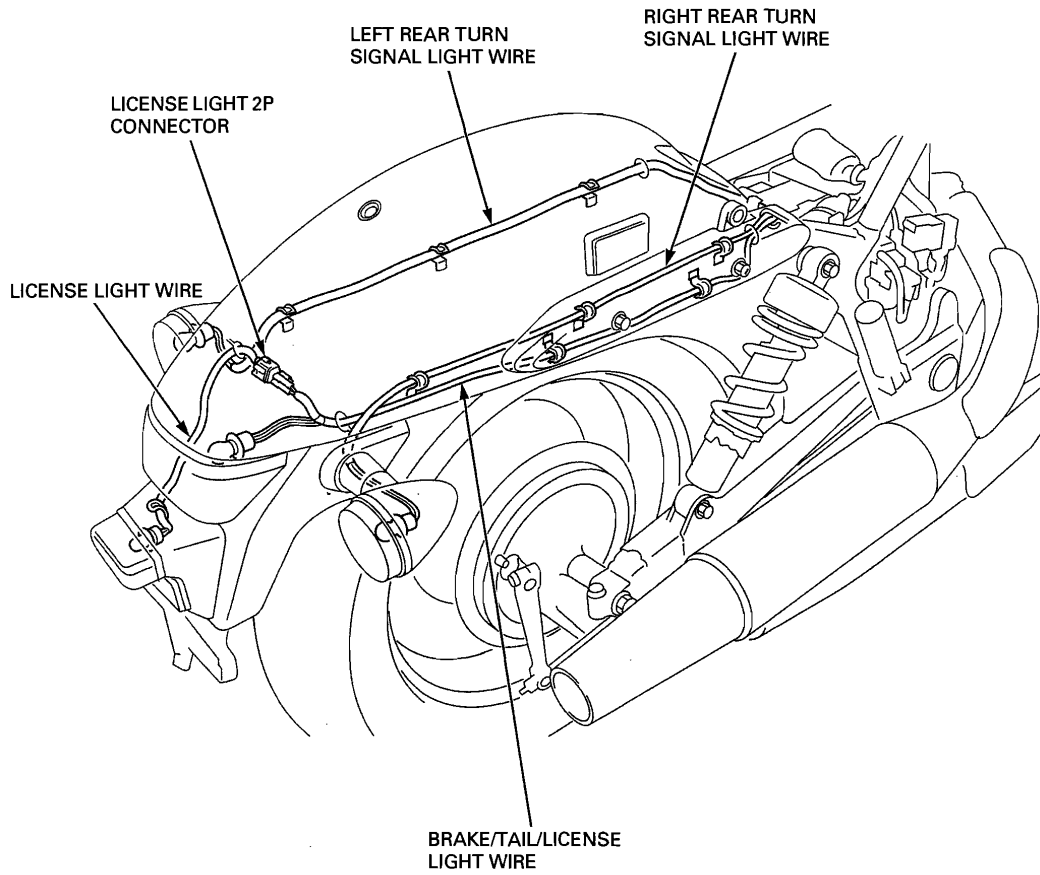

EVAP CONTROL SYSTEM (California type only)

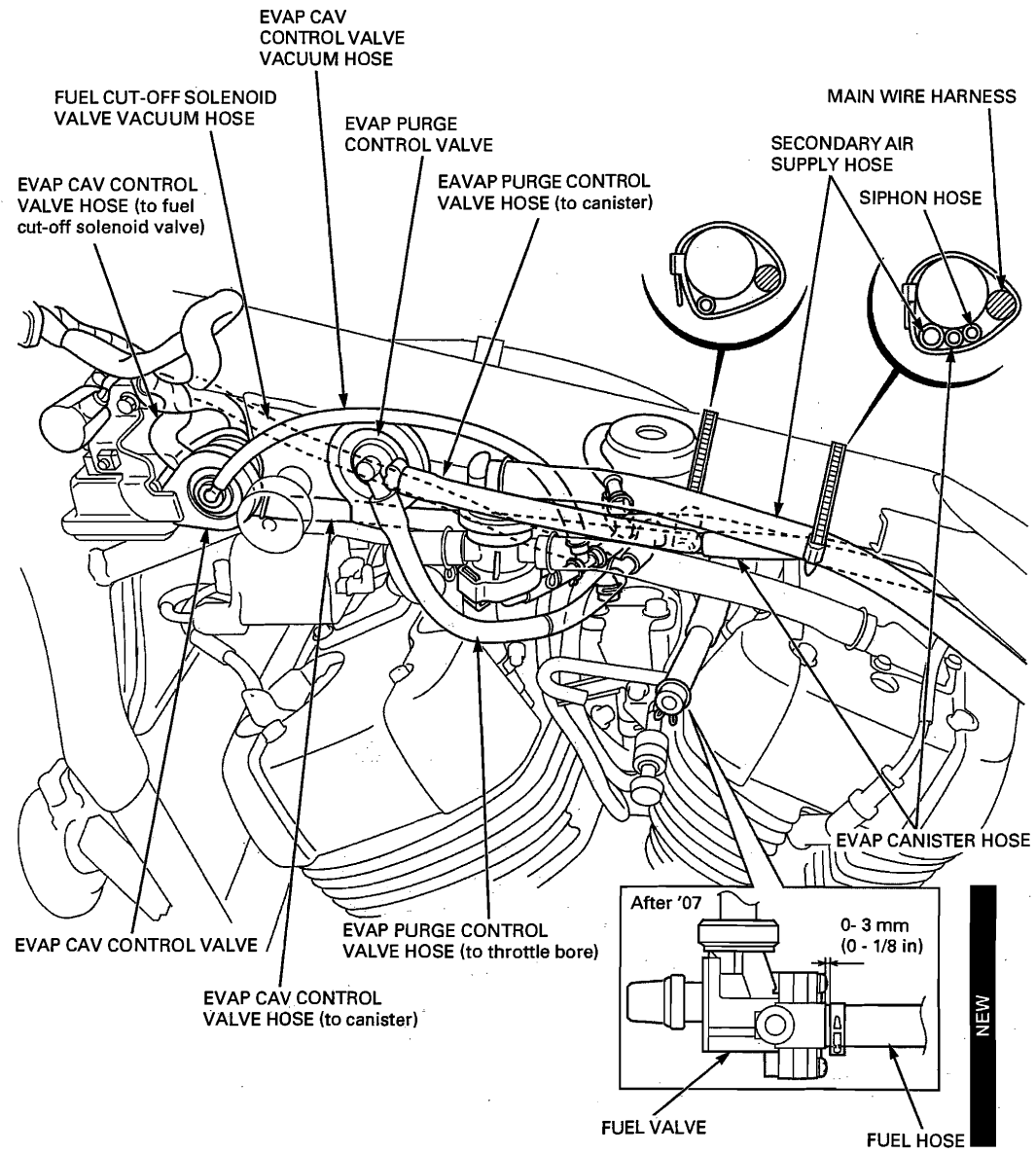

GENERAL INFORMATION

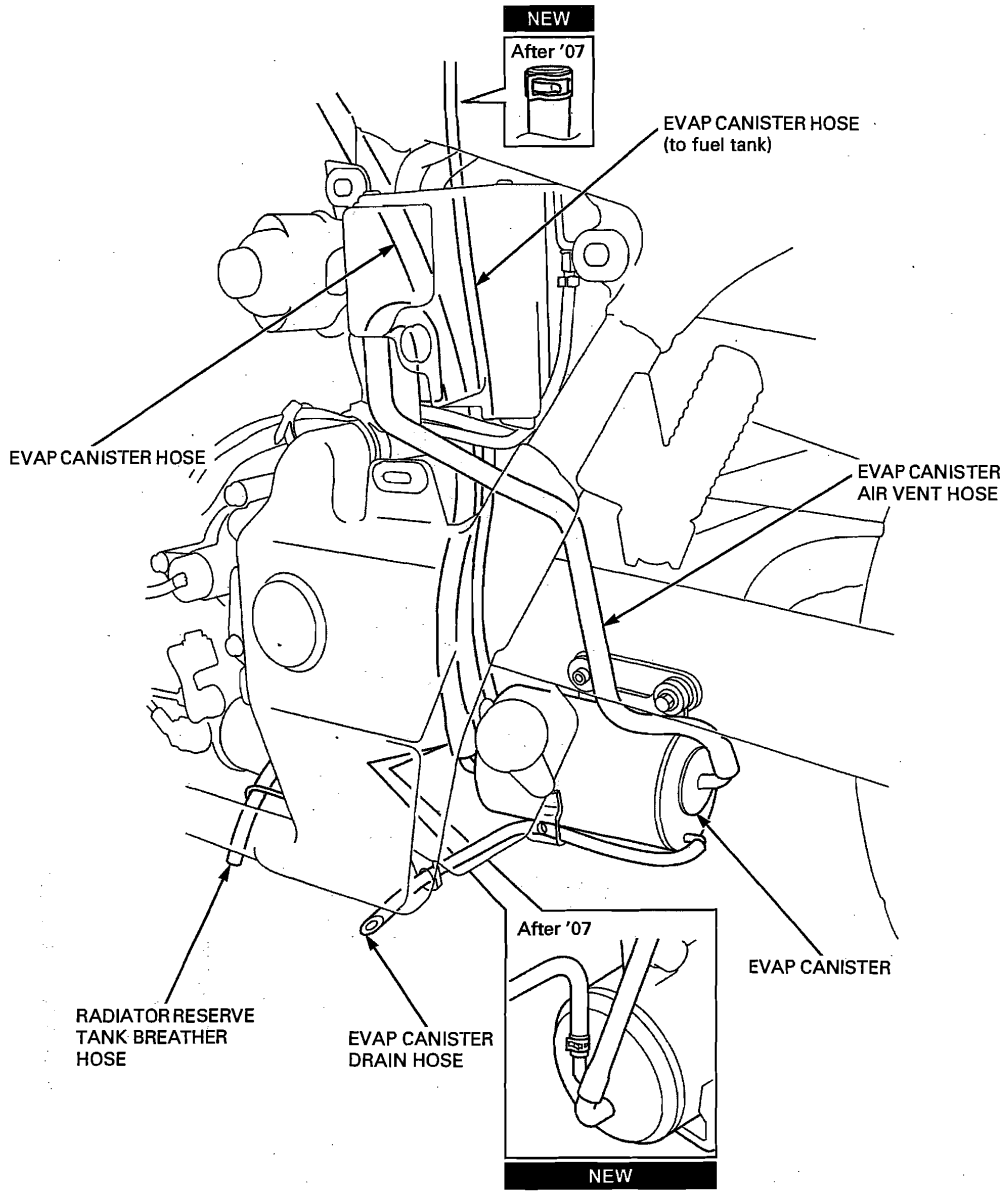

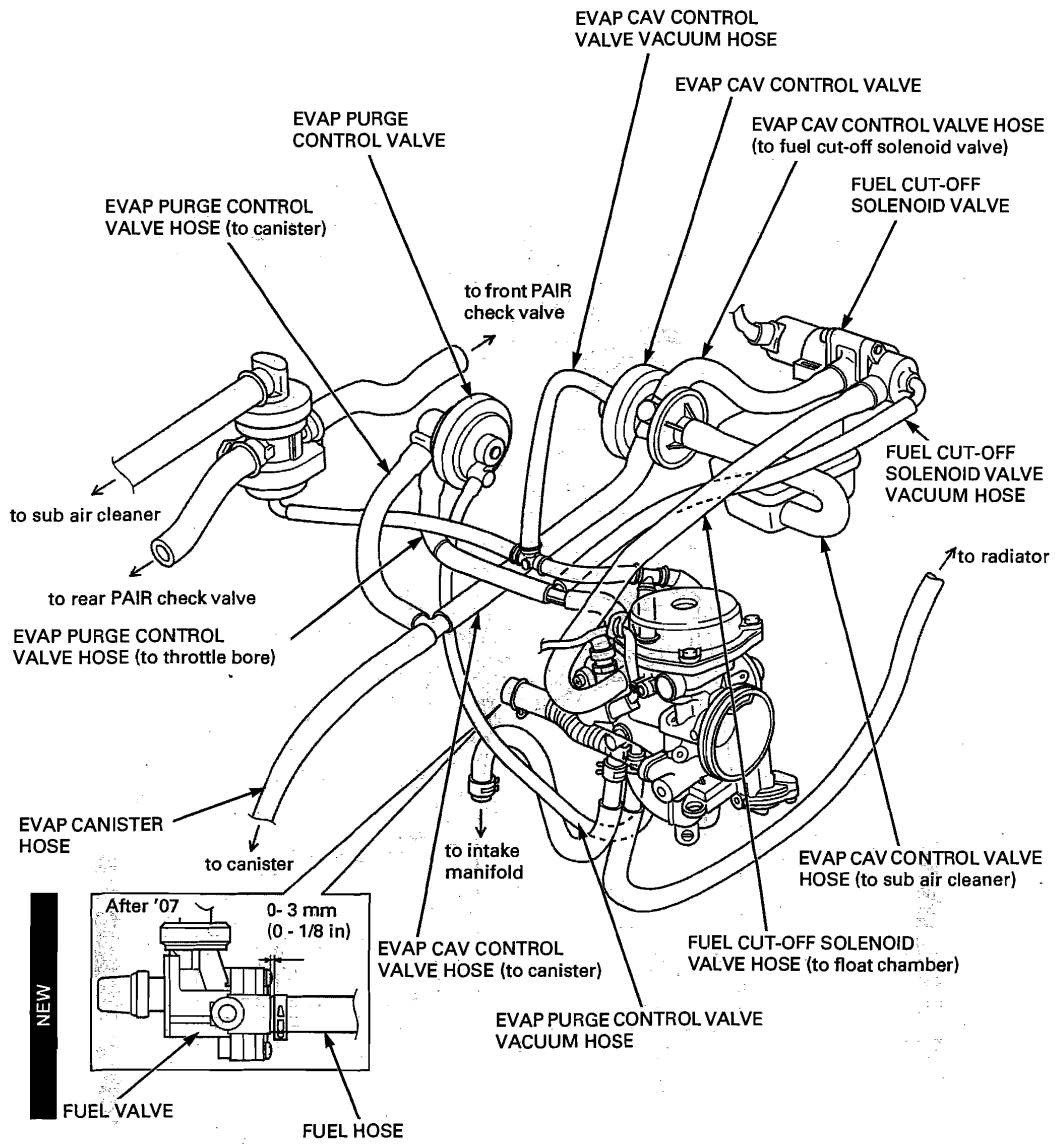

Revised: May 2007, 2007-2008 VT750C2

GENERAL INFORMATION

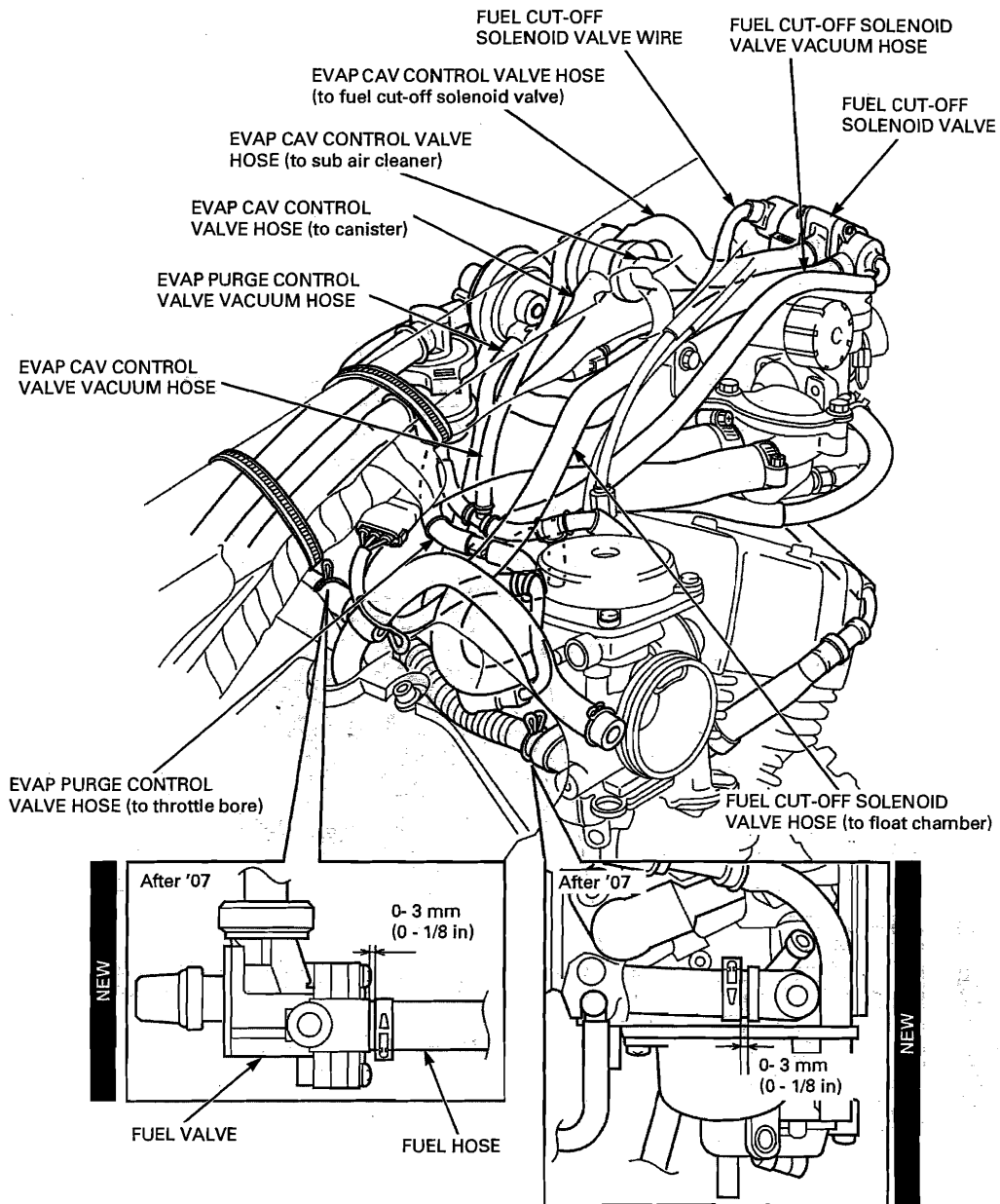

EMISSION CONTROL SYSTEMS

EXHAUST EMISSION REQUIREMENT

The U.S. Environmental Protection Agency (EPA), California Air Resources Board (CARB) and Transport Canada require manufacturers to certify that their motorcycles comply with applicable exhaust emissions standards during their useful life, when operated and maintained according to the instructions provided.

NOISE EMISSION REQUIREMENT

The EPA also required that motorcycles built after January 1, 1983 comply with applicable noise emission standards for one year or 6,000 km (3,730 miles) after the time of sale to the ultimate purchaser, when operated and maintained according to the instructions provided.

WARRANTY COMPLIANCE

Compliance with the terms of the Distributor's Limited Warranty for Honda Motorcycle Emission Control Systems is necessary in order to keep the emissions system warranty in effect.

SOURCE OF EMISSIONS

The combustion process produces carbon monoxide (CO), oxides of nitrogen (NO_x) and hydrocarbons (HC). Control of carbon monoxide, oxides of nitrogen and hydrocarbons is very important because, under certain conditions, they react to form photochemical smog when subjected to sunlight. Carbon monoxide does not react in the same way, but is toxic.

Honda Motor Co., Ltd. utilizes appropriate carburetor settings as well as other systems, to reduce carbon monoxide, and hydrocarbons.

CRANKCASE EMISSION CONTROL SYSTEM

The engine is equipped with a closed crankcase system to prevent discharging crankcase emissions into the atmosphere. Blow-by gas is returned to the combustion chamber through the air cleaner and carburetor.

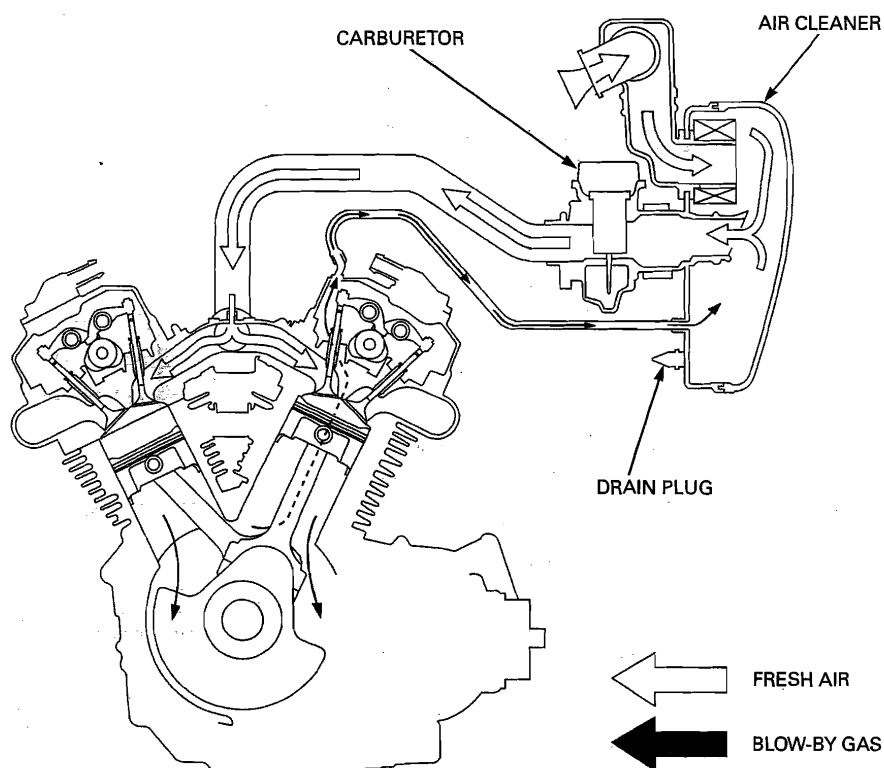

GENERAL INFORMATION

EXHAUST EMISSION CONTROL SYSTEM

The exhaust emission control system is composed of a pulse secondary air supply system and lean carburetor settings.

No adjustment should be made except idle speed adjustment with the throttle stop screw. The exhaust emission control system is separate from the crankcase emission control system.

SECONDARY AIR SUPPLY SYSTEM

The pulse secondary air supply system introduces filtered air into the exhaust gases in the exhaust port. Fresh air is drawn into the exhaust port by the function of the PAIR (Pulse Secondary Air Injection) control valve.

This charge of fresh air promotes burning of the unburned exhaust gases and changes a considerable amount of hydrocarbons and carbon monoxide into relatively harmless carbon dioxide and water vapor.

The reed valve prevents reverse air flow through the system. The PAIR control valve reacts to high intake manifold vacuum and will cut off the supply of fresh air during engine deceleration, thereby preventing afterburn in the exhaust system.

No adjustments to the secondary air supply system should be made, although periodic inspection of the components is recommended.

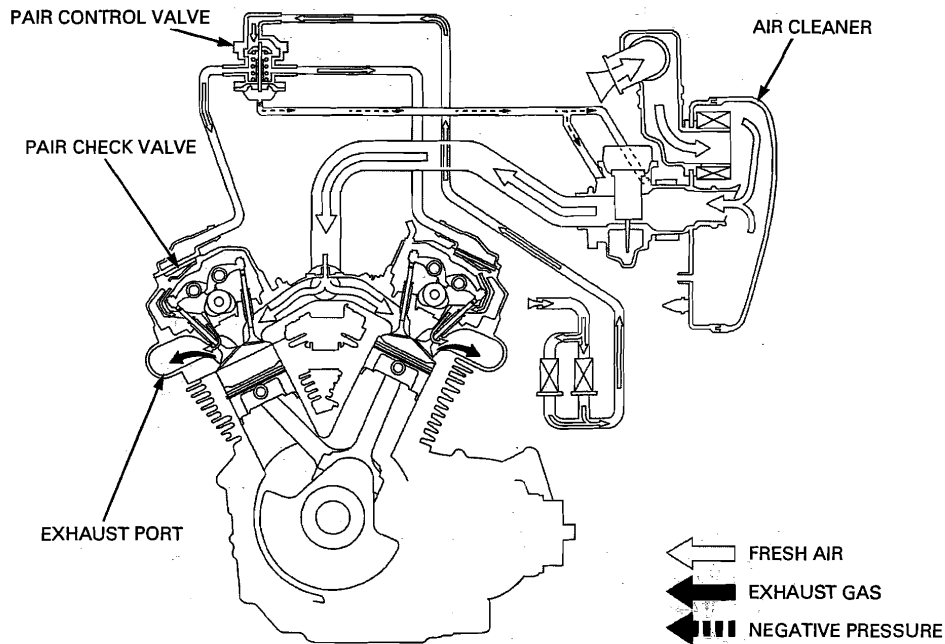

OXIDATION CATALYTIC CONVERTER (California type only)

This motorcycle is equipped with an oxidation catalytic converter.

The oxidation catalytic converter is in the exhaust system. Through chemical reactions, it converts HC and CO in the engine's exhaust to carbon dioxide (CO₂) and water vapor.

FUEL PERMEATION EMISSION CONTROL SYSTEM

NEW This motorcycle complies with the Fuel Permeation Emission regulations of the U.S. Environmental Protection Agency (EPA), California Air Resources Board (CARB), and Environment Canada (EC). The fuel tank, fuel hoses, and fuel vapor charge hoses used on this motorcycle incorporate fuel permeation control technologies. Tampering with the fuel tank, fuel hoses, or fuel vapor charge hoses to reduce or defeat the effectiveness of the fuel permeation technologies is prohibited by federal regulations.

EVAPORATIVE EMISSION CONTROL SYSTEM (California type only)

This model complies with CARB evaporative emission requirements. Fuel vapor from the fuel tank is routed into the evaporative emission (EVAP) canister where it is absorbed and stored while the engine is stopped. When the engine is running and the EVAP purge control solenoid valve is open, fuel vapor in the EVAP canister is drawn into the engine through the carburetor.

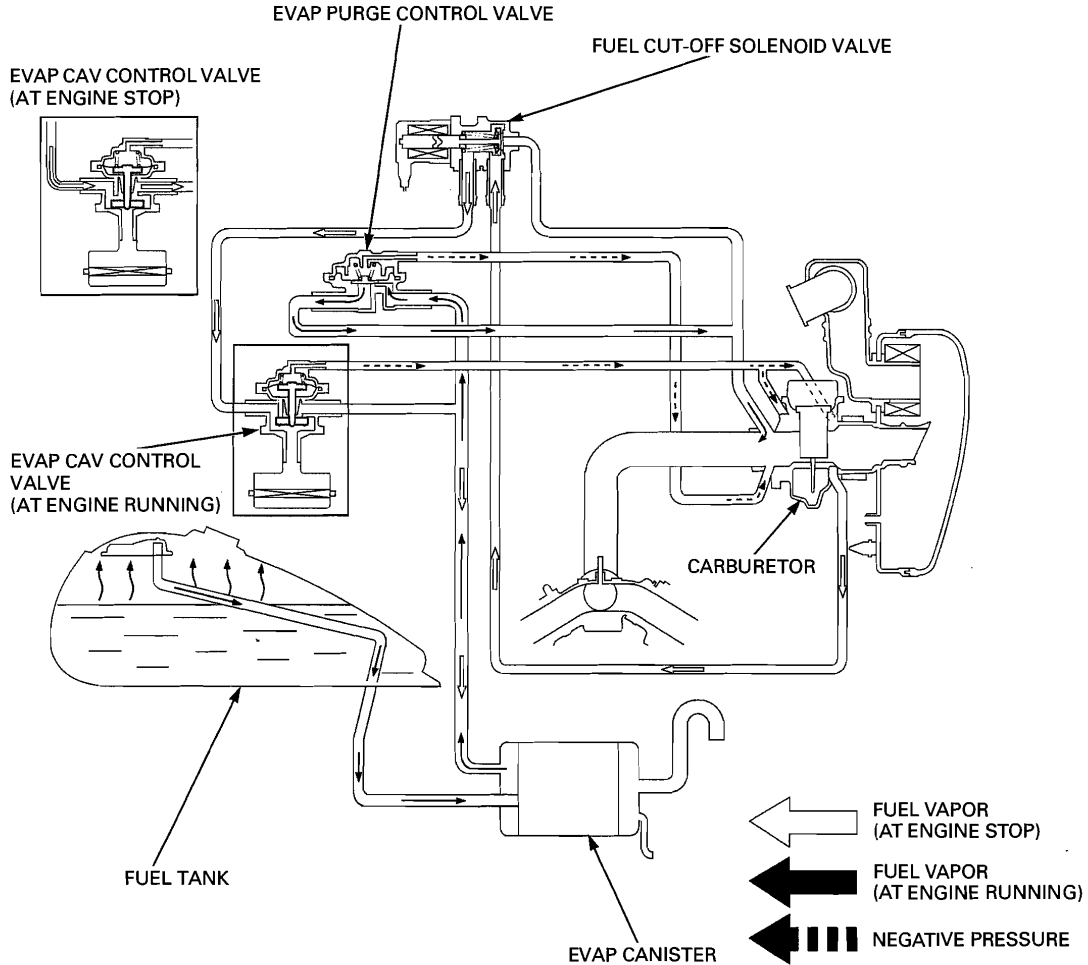

NOISE EMISSION CONTROL SYSTEM

TAMPERING WITH THE NOISE CONTROL SYSTEM IS PROHIBITED: U.S. Federal law prohibits, or Canadian provincial law may prohibit the following acts or the causing thereof: (1) The removal or rendering inoperative by any person, other than for purposes of maintenance, repair or replacement, of any device or element of design incorporated into any vehicle for the purpose of noise control prior to its sale or delivery to the ultimate customer or while it is in use; (2) the use of the vehicle after such device or element of design has been removed or rendered inoperative by any person.

AMONG THOSE ACTS PRESUMED TO CONSTITUTE TAMPERING ARE THE ACTS LISTED BELOW:

1. Removal of, or puncturing of the muffler, baffles, header pipes or any other component which conducts exhaust gases.
2. Removal of, or puncturing of any part of the intake system.
3. Lack of proper maintenance.
4. Replacing any moving parts of the vehicle, or parts of the exhaust or intake system, with parts other than those specified by the manufacturer.

OXIDATION CATALYTIC CONVERTER PROTECTION FROM UNBURNED GASOLINE (California type only)

OUTLINE

This motorcycle is equipped with heat-tube enhanced oxidation catalytic converters. Through the chemical reactions, they convert HC and CO in the engine's exhaust to carbon dioxide (CO₂) and water vapor. If the unburned (raw) gasoline from the combustion chamber flows into the catalytic converter, it will damage the catalytic converter through excessive temperatures. A damaged catalytic converter cannot be effective for exhaust emissions control.

The fuel cut-off solenoid valve and heat-tube protect the oxidation catalytic converter from damage by raw gasoline.

FUEL CUT-OFF SOLENOID VALVE

CONSTRUCTION

Raw gasoline can enter the catalytic converter under the following conditions:

- The engine stop switch is turned to "OFF" suddenly while the engine is running.
- Ignition cut system (rev limiter) operates when the engine is over revved.

The fuel cut-off solenoid valve is controlled by the ICM, and the float chamber air vent passage is changed according to above described conditions.

The fuel cut-off solenoid valve consists of a coil and valve, and 3 passages.

1. Connection to sub air cleaner (atmosphere)
2. Connection to throttle bore
3. Connection to float chamber air vent

The fuel cut-off solenoid valve opens passages 1 to 3 passage when there is no operation voltage.

OPERATION

Normal Operation (When the fuel cut-off solenoid valve does not operate):

1. No operation voltage from the ICM.
2. The float chamber air vent is open to atmosphere.
3. The float chamber pressure (surface of the gasoline in the float chamber) is atmosphere.
4. The carburetor operates normally.

Fuel Cut Operation (When the fuel cut-off solenoid valve operates):

1. The operation voltage comes from the ICM.
2. The float chamber air vent passage is closed to atmosphere.
3. The float chamber air vent is opened to the throttle bore.
4. The float chamber pressure (surface of the gasoline in the float chamber) becomes negative.
5. The float chamber pressure will be same as throttle bore pressure.
6. The carburetor stops fuel supply.

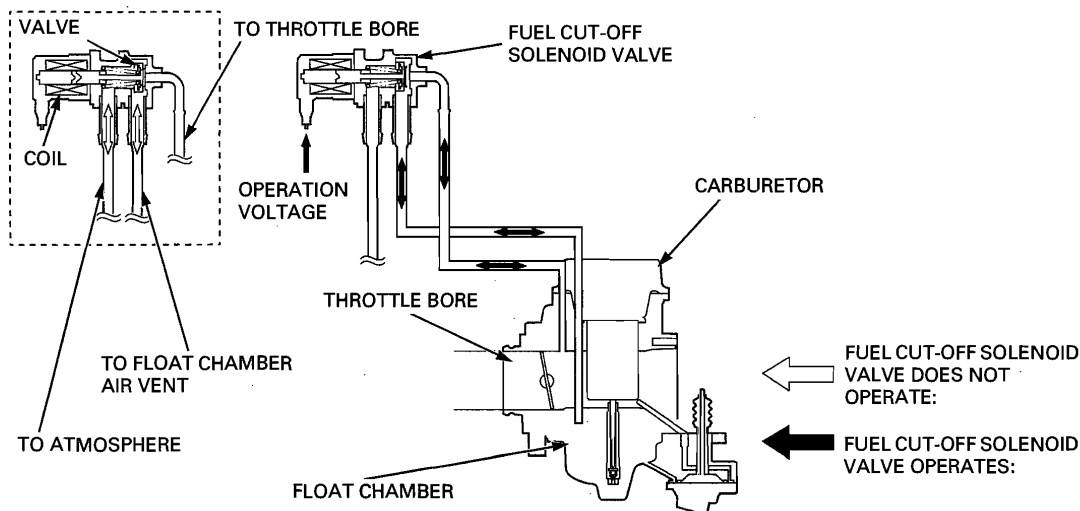

HEAT-TUBE

Raw gasoline can enter the catalytic converter under the following conditions:

- The engine stop switch is turned to "⊗" suddenly while the engine is running.
- The engine stop switch is turned to "⊗" suddenly while the engine is running and the throttle is snapped open (additional fuel is discharged from the accelerator pump).

The heat-tube is installed upstream of the oxidation catalytic converter to protect the catalytic converter from damage by chemical reactions.

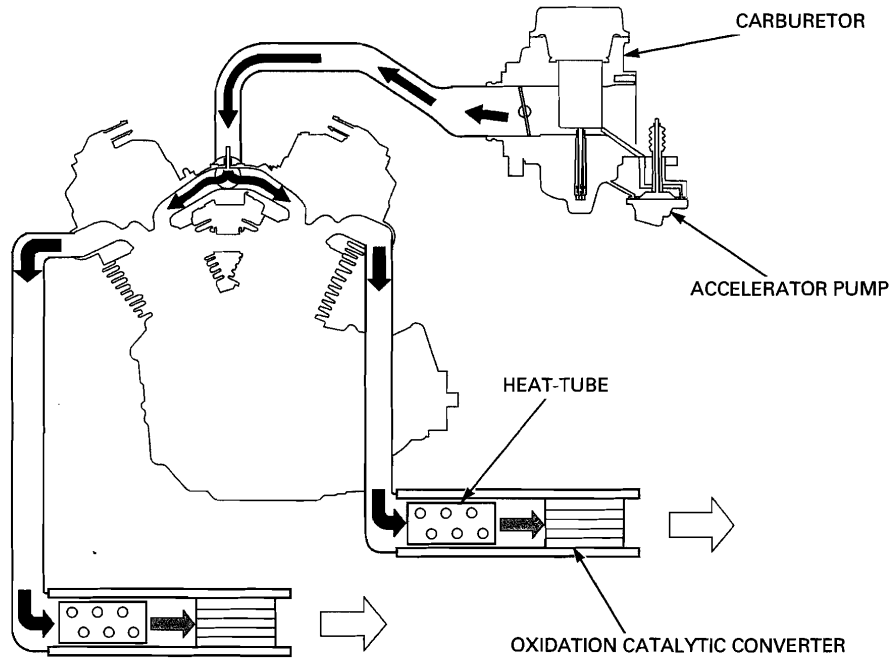

3. FRAME/BODY PANELS/EXHAUST SYSTEM

SERVICE INFORMATION	3-2	STEERING SIDE COVER	3-5
TROUBLESHOOTING	3-2	LEFT CRANKCASE REAR COVER	3-5
SEAT.....	3-3	FRONT FENDER	3-6
SIDE COVER.....	3-3	REAR FENDER	3-6
FUEL TANK	3-4	EXHAUST SYSTEM	3-8

SERVICE INFORMATION

GENERAL

- This section covers removal and installation of the body panels, fuel tank and exhaust system.
- Serious burns may result if the exhaust system is not allowed to cool before components are removed or serviced.
- Always replace the exhaust system gaskets with new ones after removing the exhaust system from the engine.
- When installing the exhaust system, loosely install all of the exhaust pipe fasteners. Always tighten the exhaust clamps first, then tighten the mounting fasteners.
- Always inspect the exhaust system for leaks after installation.

TORQUE VALUES

Seat mounting socket 8 mm bolt	26 N·m (2.7 kgf·m, 19 lbf·ft)
Grab rail mounting bolt	64 N·m (6.5 kgf·m, 47 lbf·ft)
Fuel tank mounting bolt	27 N·m (2.8 kgf·m, 20 lbf·ft)
Fuel valve nut	34 N·m (3.5 kgf·m, 25 lbf·ft)
Left crankcase rear cover socket bolt	10 N·m (1.0 kgf·m, 7 lbf·ft)
Exhaust pipe joint nut	25 N·m (2.5 kgf·m, 18 lbf·ft)
Muffler stay mounting bolt	27 N·m (2.8 kgf·m, 20 lbf·ft)
Muffler mounting nut	44 N·m (4.5 kgf·m, 32 lbf·ft)
Muffler bracket bolt	34 N·m (3.5 kgf·m, 25 lbf·ft)
Exhaust pipe joint stud bolt	See page 3-11

TROUBLESHOOTING

Excessive exhaust noise

- Broken exhaust system
- Exhaust gas leak

Poor performance

- Deformed exhaust system
- Exhaust gas leaks
- Clogged muffler

SEAT

REMOVAL

Remove the 8 mm socket bolts, 6 mm bolt, washer and seat by moving it rearward.

INSTALLATION

Install the seat by inserting its prong under the raised lip of the frame.

Install the washer, 6 mm bolt and tighten the 6 mm bolt securely.

Install and tighten the 8 mm socket bolts to the specified torque.

TORQUE: 26 N·m (2.7 kgf·m, 19 lbf·ft)

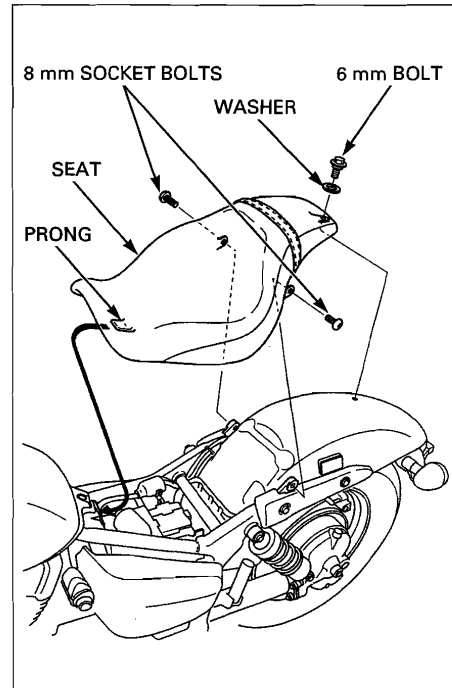

SIDE COVER

REMOVAL/INSTALLATION

Be careful not to damage the side cover bosses.

Remove the side cover by releasing its bosses from the frame grommets.

Install the side cover by inserting its bosses into the frame grommets.

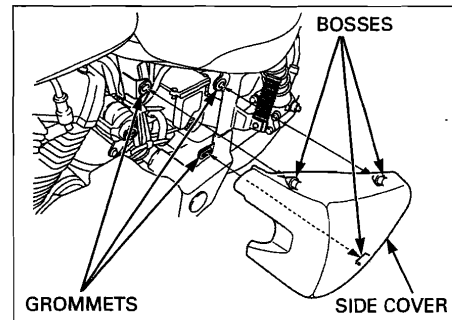

FUEL TANK

REMOVAL

Remove the following:

- Speedometer assembly (page 21-10)
- Seat (page 3-3)

Turn the fuel valve to OFF.

Disconnect the fuel and vacuum hoses from the fuel valve.

Disconnect the breather hose (California type: EVAP canister hose) from the fuel tank.

Remove the mounting bolt, washer and collar.

Remove the fuel tank by moving it rearward.

INSTALLATION

Install the fuel tank by inserting its grooves over the mounting rubbers.

Install the collar and washer with the flat of the washer facing rearward.

Install and tighten the mounting bolt to the specified torque.

TORQUE: 27 N-m (2.8 kgf-m, 20 lbf-ft)

Route the hoses properly (page 1-22).

Install the removed parts in the reverse order of removal.

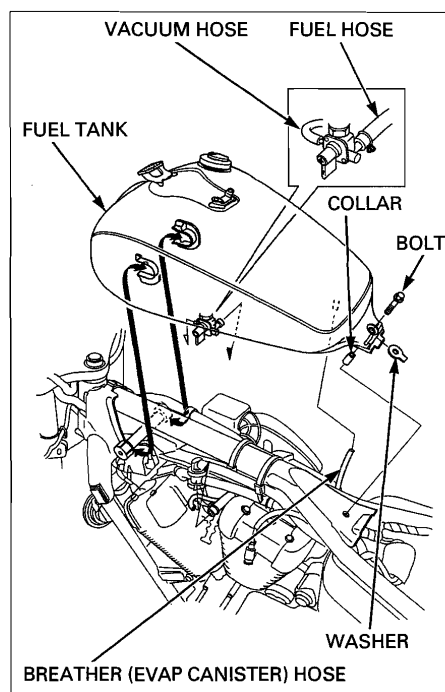

DISASSEMBLY

Remove the fuel tank (page 3-4).

Drain the fuel from the fuel tank into an approved gasoline container.

Loosen the nut and remove the fuel valve.

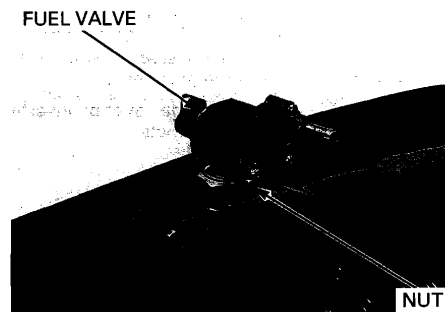

Remove the fuel strainer screen and O-ring.

Wash the fuel strainer screen in high flash-point cleaning solvent.

Check the fuel strainer screen for clog or damage, replace it if necessary.

ASSEMBLY

Install a new O-ring and fuel strainer screen to the fuel valve.

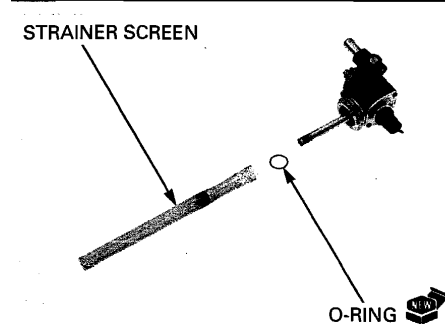

Install the fuel valve into the fuel tank.
Tighten the nut to the specified torque while holding the fuel valve.

TORQUE: 34 N·m (3.5 kgf·m, 25 lbf·ft)

Install the fuel tank (page 3-4).

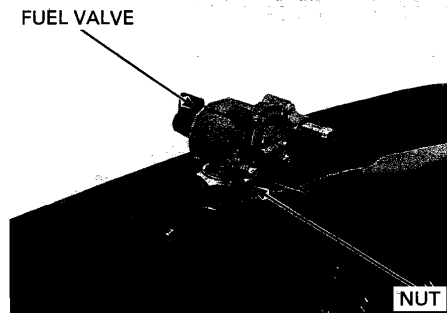

STEERING SIDE COVER

REMOVAL/INSTALLATION

Remove the speedometer assembly (page 21-10).

Remove the bolts.

Remove the retaining clip by sliding it rearward.

Be careful not to damage the boss and slot.

Remove the steering side covers by releasing the left cover boss from the right cover slot.

Installation is in the reverse order of removal.

NOTE:

After installation, check that the wire harness and cables do not interfere with handlebar rotation.

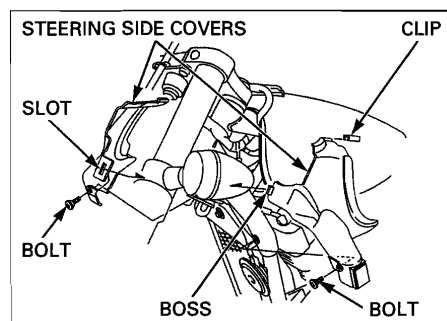

LEFT CRANKCASE REAR COVER

REMOVAL/INSTALLATION

Remove the B-clip and washer.

Remove the socket bolt and left crankcase rear cover by releasing its bosses from the grommets.

Check the B-clip for fatigue or damage, replace it if necessary.

Installation is in the reverse order of removal.

TORQUE:

**Left crankcase rear cover socket bolt:
10 N·m (1.0 kgf·m, 7 lbf·ft)**

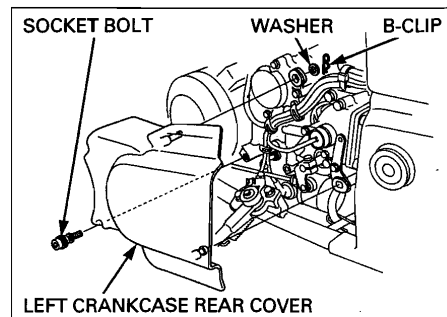

FRONT FENDER

REMOVAL/INSTALLATION

Remove the following:

- Bolts
- Nuts
- Collars
- Front fender brace
- Front fender
- Grommets

Installation is in the reverse order of removal.

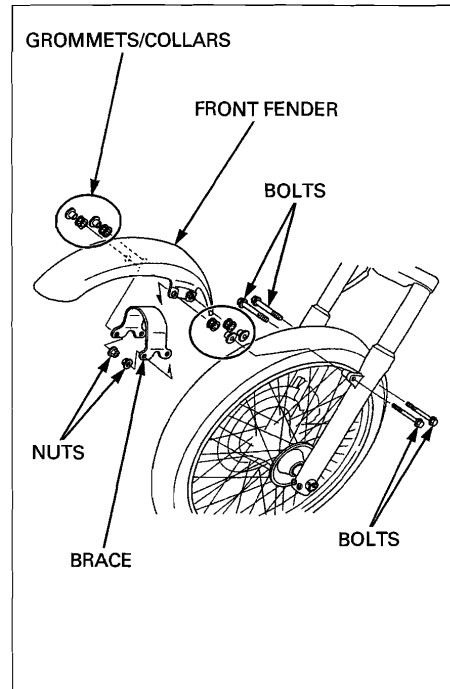

REAR FENDER

REAR FENDER ASSEMBLY

REMOVAL

Remove the seat (page 3-3).

Disconnect the brake/tail/license light 3P and rear turn signal light 2P connectors.

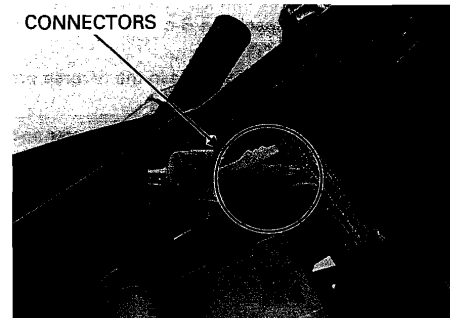

Remove the following:

- Bolts
- Washers
- Grab rails
- Rear fender assembly

NOTE:

When removing the rear fender assembly, be careful not to damage the wires.

INSTALLATION

Installation is in the reverse order of removal.

TORQUE:

Grab rail mounting bolt:
64 N·m (6.5 kgf·m, 47 lbf·ft)

Route the wires properly (page 1-22).

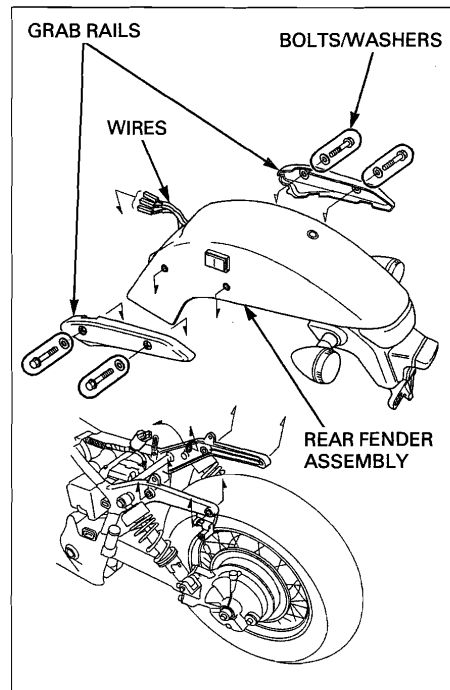

REAR FRAME/REAR FENDER A

REMOVAL

Remove the rear fender assembly (page 3-6).

Release the rear frame bosses from the rear fender holes, then remove the rear frame/rear fender A.

NOTE:

When removing the rear frame/rear fender A, be careful not to damage the wires.

Remove the rubber from the rear fender A.
Remove the grommet from the rear fender.

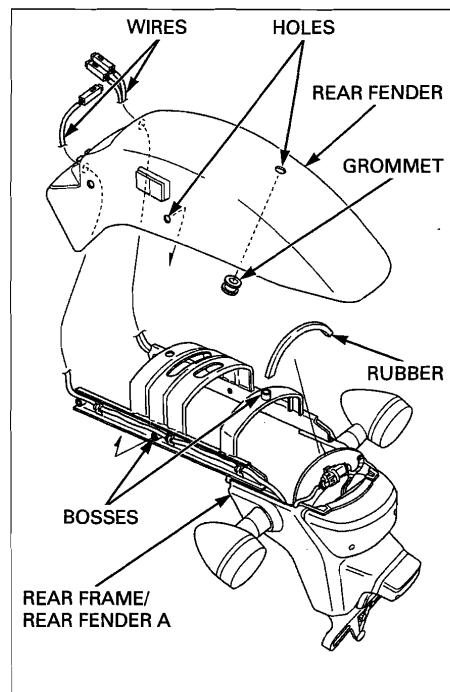

FRAME/BODY PANELS/EXHAUST SYSTEM

DISASSEMBLY/ASSEMBLY

Remove the following:

- Rear turn signal lights (page 21-7)
- Brake/tail light (page 21-8)
- License light (page 21-8)

Remove the mounting bolt, collars, grommets and rear fender A.

Remove the nut and reflector.

Assembly is in the reverse order of disassembly.

INSTALLATION

Installation is in the reverse order of removal.

Route the wires properly (page 1-22).

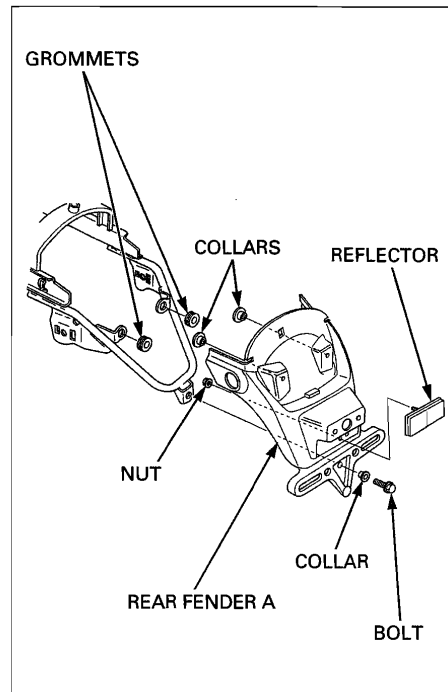

EXHAUST SYSTEM

REMOVAL

Remove the exhaust pipe joint nuts.

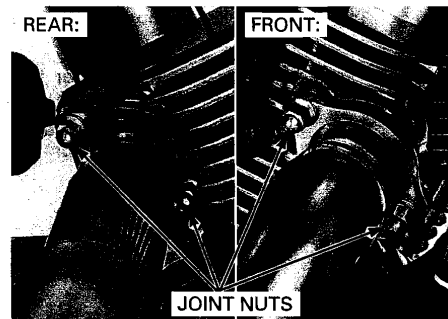

Remove the nuts, bolts, washers, collars and muffler assembly.

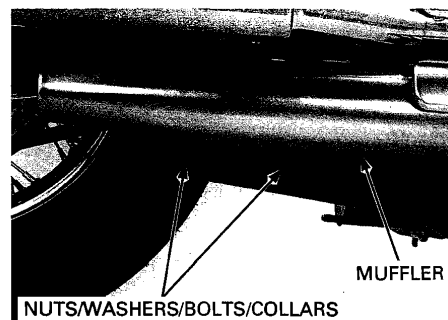

Remove the front and rear gaskets.

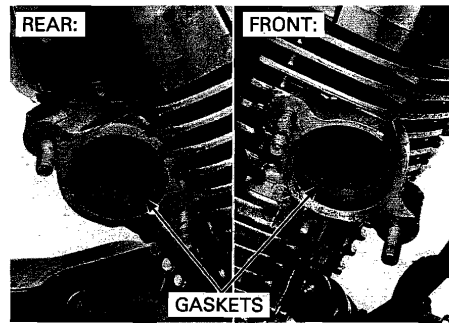

Remove the exhaust pipe joint collars and flanges.

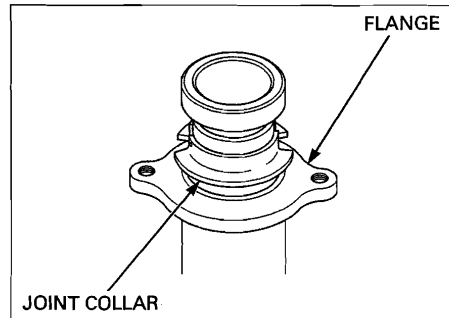

DISASSEMBLY

Rear muffler only: Drive the rear exhaust pipe protector using a plastic hammer and break the lock tab (reverse side of the protector) and remove it.

NOTE:

- The rear exhaust pipe protector can be removed without removing the exhaust system from the engine.
- Do not reuse the removed protector.

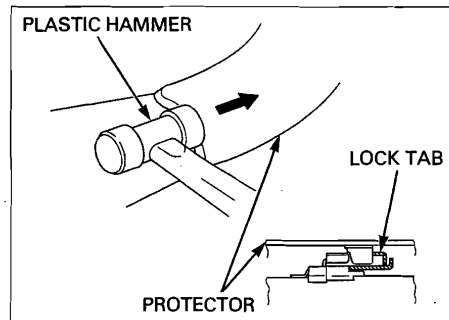

Loosen the muffler joint band bolt.

Remove the mounting bolts, muffler stay and separate the mufflers.

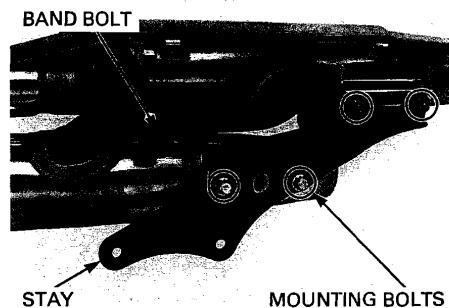

ASSEMBLY

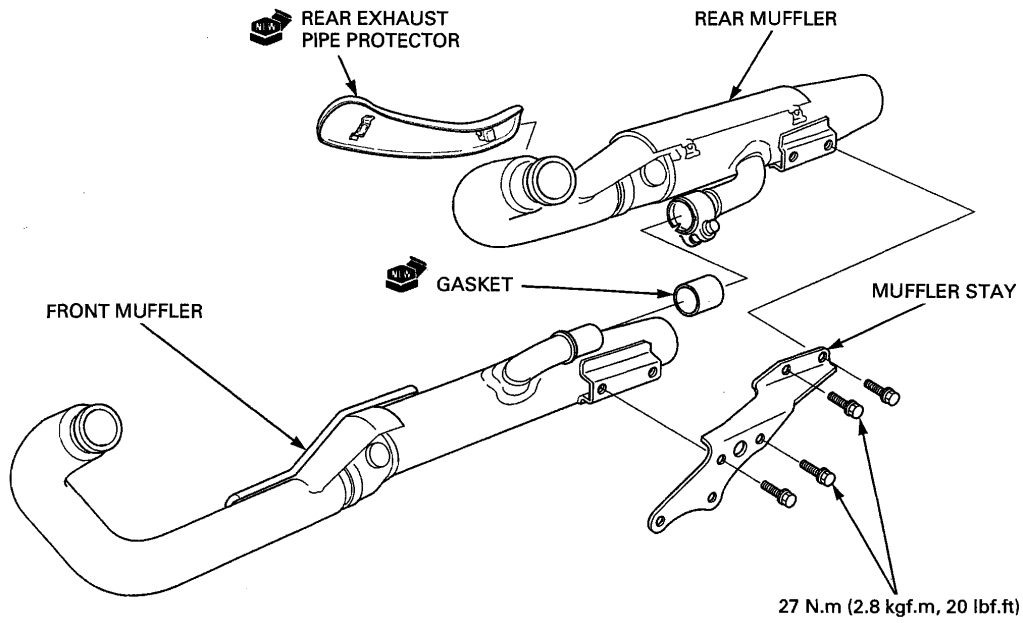

Install a new gasket onto the front muffler joint pipe.
 Assemble the front muffler and rear muffler.
 Install the muffler stay, mounting bolts and tighten the mounting bolts to the specified torque.
TORQUE: 27 N·m (2.8 kgf·m, 20 lbf·ft)
 Tighten the muffler joint band bolt securely.

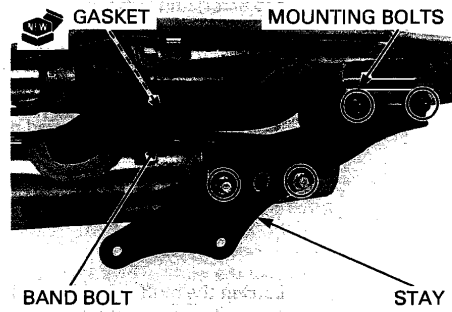

Rear muffler only: Install a new rear exhaust pipe protector.

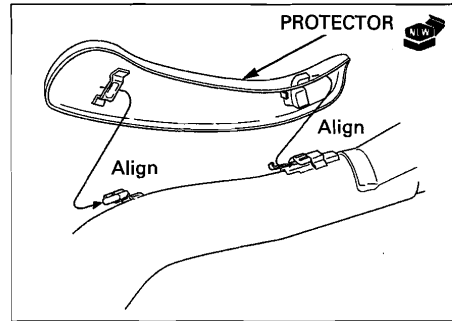

INSTALLATION

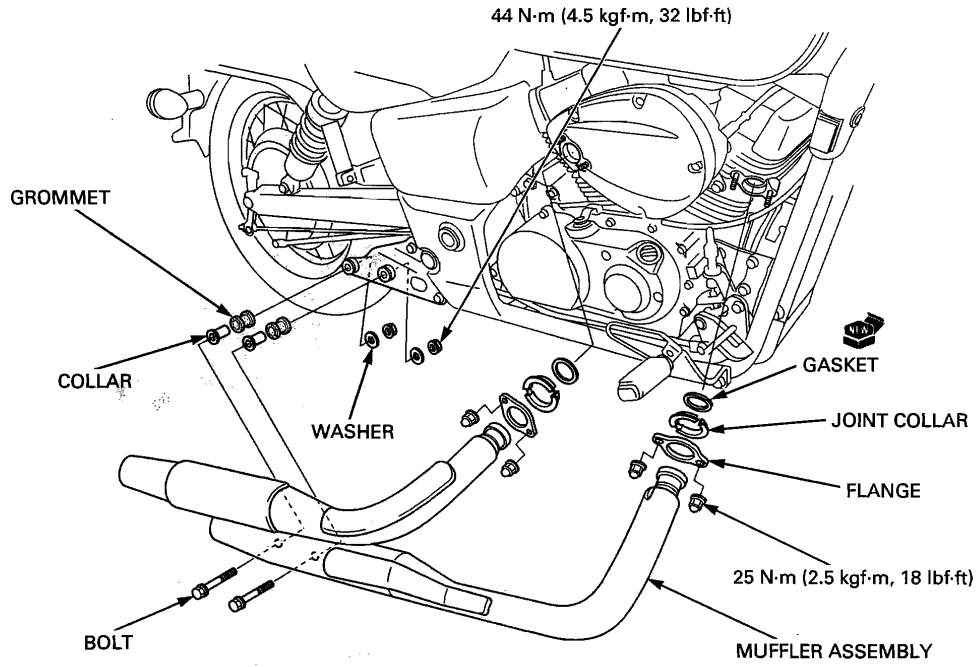

If the exhaust pipe joint stud bolts are loose, tighten them. Be sure to verify the distance from the top of the stud to the cylinder head as shown.

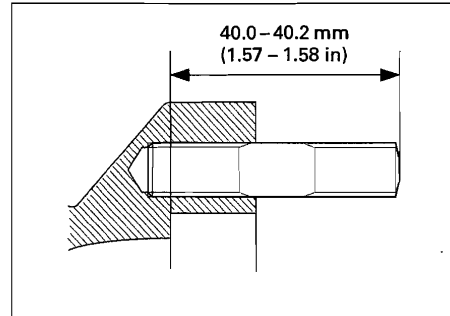

Install the flanges and exhaust pipe joint collars.

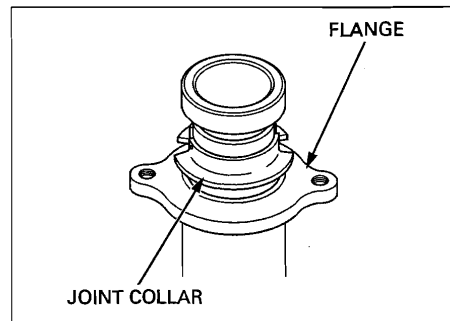

FRAME/BODY PANELS/EXHAUST SYSTEM

Install new gaskets.

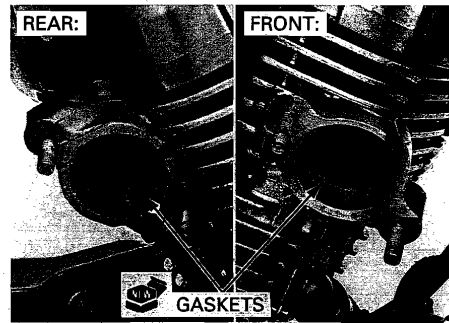

Install the muffler assembly.

NOTE:

Inserting the rear exhaust pipe to the rear exhaust port first, then insert the front exhaust pipe to the front exhaust port.

Temporarily install the all fasteners.

Tighten the exhaust pipe joint nuts to the specified torque.

TORQUE: 25 N·m (2.5 kgf·m, 18 lbf·ft)

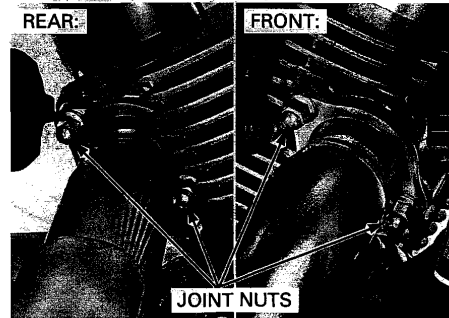

Tighten the muffler mounting nuts to the specified torque.

TORQUE: 44 N·m (4.5 kgf·m, 32 lbf·ft)

NOTE:

Always inspect the exhaust system for leaks after installation.

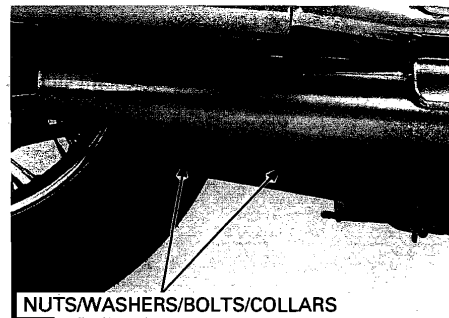

SERVICE INFORMATION	4-2	SECONDARY AIR SUPPLY SYSTEM	4-16
MAINTENANCE SCHEDULE	4-4	EVAP CONTROL SYSTEM (California type only)	4-17
FUEL LINE	4-5	FINAL DRIVE OIL	4-18
THROTTLE OPERATION	4-5	BRAKE FLUID	4-19
CHOKE OPERATION	4-6	BRAKE SHOES/PADS WEAR	4-20
AIR CLEANER	4-7	BRAKE SYSTEM	4-20
SUB AIR CLEANER	4-8	BRAKE LIGHT SWITCH	4-22
CRANKCASE BREATHER	4-8	HEADLIGHT AIM	4-22
SPARK PLUG	4-9	CLUTCH SYSTEM	4-22
VALVE CLEARANCE	4-10	SIDESTAND	4-23
ENGINE OIL	4-12	SUSPENSION	4-24
ENGINE OIL FILTER	4-13	NUTS, BOLTS, FASTENERS	4-24
ENGINE IDLE SPEED	4-15	WHEELS/TIRES	4-25
RADIATOR COOLANT	4-15	STEERING HEAD BEARINGS	4-26
COOLING SYSTEM	4-15		

MAINTENANCE

SERVICE INFORMATION

GENERAL

- Place the motorcycle on level ground before starting any work.
- Gasoline is extremely flammable and is explosive under certain conditions.
- Work in a well ventilated area. Smoking or allowing flames or sparks in the work area or where the gasoline is stored can cause a fire or explosion.
- The exhaust contains poisonous carbon monoxide gas that may cause loss of consciousness and may lead to death. Run the engine in an open area or with an exhaust evacuation system in an enclosed area.

SPECIFICATIONS

ITEM		SPECIFICATIONS	
Throttle grip freeplay		2 – 6 mm (1/16 – 1/4 in)	
Spark plug	Standard	DPR6EA-9 (NGK), X20EPR-U9 (DENSO)	
	For extended high speed riding	DPR7EA-9 (NGK), X22EPR-U9 (DENSO)	
Spark plug gap		0.8 – 0.9 mm (0.03 – 0.04 in)	
Valve clearance	IN	0.15 ± 0.02 mm (0.006 ± 0.001 in)	
	EX	0.20 ± 0.02 mm (0.008 ± 0.001 in)	
Recommended engine oil		Pro Honda GN4 4-stroke oil (U.S.A. and Canada) or equivalent motor oil API service classification: SG or higher JASO T 903 standard: MA Viscosity: SAE 10W-30	
Engine oil capacity	At draining	2.5 liters (2.6 US qt, 2.2 Imp qt)	
	At oil filter change	2.6 liters (2.7 US qt, 2.3 Imp qt)	
	At disassembly	3.2 liters (3.4 US qt, 2.8 Imp qt)	
Engine idle speed		1,200 ± 100 rpm	
Recommended antifreeze		Pro Honda HP coolant or an equivalent high quality ethylene glycol antifreeze containing silicate-free corrosion inhibitors	
Recommended final drive oil		Hypoid gear oil, SAE #80	
Final drive oil capacity	At draining	160 cm ³ (5.4 US oz, 5.6 Imp oz)	
	At disassembly	170 cm ³ (5.7 US oz, 6.0 Imp oz)	
Recommended brake fluid		DOT 4	
Brake pedal height		75 mm (3.0 in) above the top of the footpeg	
Brake pedal freeplay		20 – 30 mm (13/16 – 1-3/16 in)	
Clutch lever freeplay		10 – 20 mm (3/8 – 13/16 in)	
Cold tire pressure	Up to 90 kg (200 lbs) load	Front	200 kPa (2.00 kgf/cm ² , 29 psi)
		Rear	200 kPa (2.00 kgf/cm ² , 29 psi)
	Up to maximum weight capacity	Front	200 kPa (2.00 kgf/cm ² , 29 psi)
		Rear	250 kPa (2.50 kgf/cm ² , 36 psi)
Tire size	Front	90/90-21M/C 54S	
	Rear	160/80-15M/C 74S	
Tire brand	BRIDGESTONE	Front	EXEDRA G701
		Rear	EXEDRA G702
	DUNLOP	Front	D404F
		Rear	D404
Minimum tire tread depth	Front	1.5 mm (0.06 in)	
	Rear	2.0 mm (0.08 in)	

TORQUE VALUES

Spark plug	18 N·m (1.8 kgf·m, 13 lbf·ft)	Apply engine oil to the threads and seating surface
Valve adjusting screw lock nut	23 N·m (2.3 kgf·m, 17 lbf·ft)	
Timing hole cap	10 N·m (1.0 kgf·m, 7 lbf·ft)	Apply grease to the threads
Engine oil filter cartridge	26 N·m (2.7 kgf·m, 19 lbf·ft)	
Engine oil drain bolt	29 N·m (3.0 kgf·m, 21 lbf·ft)	Apply engine oil to the threads
Final drive oil filler cap	12 N·m (1.2 kgf·m, 9 lbf·ft)	
Final drive oil drain bolt	12 N·m (1.2 kgf·m, 9 lbf·ft)	Apply grease to the threads
Front master cylinder reservoir cap screw	1.5 N·m (0.2 kgf·m, 1.1 lbf·ft)	
Air cleaner cover socket bolt	1.5 N·m (0.2 kgf·m, 1.1 lbf·ft)	
Crankshaft hole cap	15 N·m (1.5 kgf·m, 11 lbf·ft)	
Alternator cover socket bolt	10 N·m (1.0 kgf·m, 7 lbf·ft)	
Spoke	4.2 N·m (0.4 kgf·m, 3.1 lbf·ft)	
SE valve nut	2.3 N·m (0.2 kgf·m, 1.7 lbf·ft)	

TOOLS

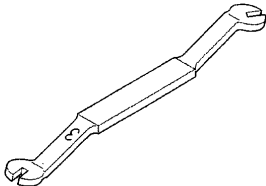
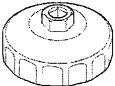
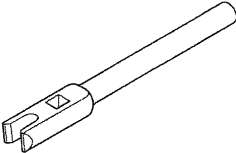
<p>Valve adjusting wrench 07908-KE90000</p>  <p>or 07908-KE90100 (U.S.A. only) with 10-mm offset box wrench</p>	<p>Oil filter wrench 07HAA-PJ70101</p>  <p>or 07HAA-PJ70100 (U.S.A. only) or 07HAA-PLCA100 (U.S.A. only)</p>	<p>Spoke wrench 07JMA-MR60100</p> 
--	---	---

MAINTENANCE

MAINTENANCE SCHEDULE

Perform the Pre-ride inspection in the Owner's Manual at each scheduled maintenance period.

I: Inspect and clean, adjust, lubricate or replace if necessary. C: Clean. R: Replace. A: Adjust. L: Lubricate.

The following items require some mechanical knowledge. Certain items (particularly those marked * and **) may require more technical information and tools. Consult your Honda dealer.

ITEMS	FREQUENCY	WHICHEVER COMES FIRST ↓	ODOMETER READING (NOTE 1)								REFER TO PAGE	
			X1,000 mi X1,000 km	0.6 1.0	4 6.4	8 12.8	12 19.2	16 25.6	20 32.0	24 38.4		
EMISSION RELATED ITEMS	* FUEL LINE					I			I		I	4-5
	* THROTTLE OPERATION					I			I		I	4-5
	* CHOKE OPERATION					I			I		I	4-6
	AIR CLEANER	NOTE 2					R				R	4-7
	* SUB AIR CLEANER						R				R	4-8
	CRANKCASE BREATHER	NOTE 3			C	C	C	C	C	C	C	4-8
	SPARK PLUG				I	R	I	R	I	R	I	4-9
	* VALVE CLEARANCE				I		I		I		I	4-10
	ENGINE OIL			INITIAL = 600 mi (1,000 km) or 1 month : R REGULAR = Every 8,000 mi (12,800 km) or 12 months : R								4-12
	ENGINE OIL FILTER				R		R		R		R	4-13
	* ENGINE IDLE SPEED				I	I	I	I	I	I	I	4-15
	RADIATOR COOLANT	NOTE 4				I		I			R	4-15
	* COOLING SYSTEM					I		I		I	I	4-15
* SECONDARY AIR SUPPLY SYSTEM					I		I		I	I	4-16	
* EVAP CONTROL SYSTEM	NOTE 5					I				I	4-17	
NON-EMISSION RELATED ITEMS	FINAL DRIVE OIL				I		I			R	4-18	
	BRAKE FLUID	NOTE 4			I	I	R	I	I	R	4-19	
	BRAKE SHOES/PADS WEAR				I	I	I	I	I	I	4-20	
	BRAKE SYSTEM			I		I		I		I	4-20	
	* BRAKE LIGHT SWITCH					I		I		I	4-22	
	* HEADLIGHT AIM					I		I		I	4-22	
	CLUTCH SYSTEM			I	I	I	I	I	I	I	4-22	
	SIDESTAND					I		I		I	4-23	
	* SUSPENSION					I		I		I	4-24	
	* NUTS, BOLTS, FASTENERS			I		I		I		I	4-24	
** WHEELS/TIRES			I	I	I	I	I	I	I	4-25		
** STEERING HEAD BEARINGS			I		I		I		I	4-26		

* Should be serviced by your dealer, unless the owner has proper tools and service data and is mechanically qualified

** In the interest of safety, we recommend these items be serviced only by your Honda dealer

NOTES:

1. At higher odometer reading, repeat at the frequency interval established here.
2. Service more frequently when riding in unusually wet or dusty areas.
3. Service more frequently when riding in rain or at full throttle.
4. Replace every 2 years, or at indicated odometer interval, whichever comes first. Replacement requires mechanical skill.
5. California type only.

FUEL LINE

Check the fuel line for deterioration, damage or leakage.
Replace the fuel line if necessary.

Also check the fuel valve vacuum hose for damage.
Replace the vacuum hose if necessary.

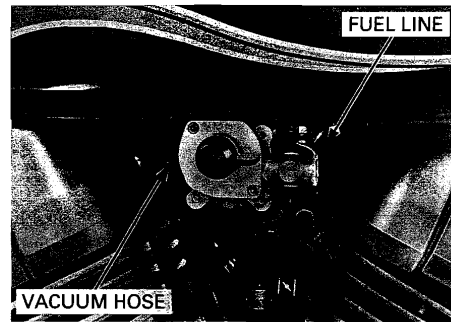

THROTTLE OPERATION

Check for any deterioration or damage to the throttle cables. Check the throttle grip for smooth operation. Check that the throttle opens and automatically closes in all steering positions.

If the throttle grip does not return properly, lubricate the throttle cables and overhaul and lubricate the throttle grip housing.

If the throttle grip still does not return properly, replace the throttle cables.

With the engine idling, turn the handlebar all the way to the right and left to ensure that the idle speed does not change. If idle speed increases, check the throttle grip freeplay and the throttle cable connection.

Measure the throttle grip freeplay at the throttle grip flange.

FREEPLAY: 2 – 6 mm (1/16 – 1/4 in)

Throttle grip freeplay can be adjusted at either end of the throttle cable.

Minor adjustment is made with the upper adjuster.

Loosen the lock nut, turn the adjuster as required.
Tighten the lock nut while holding the adjuster.

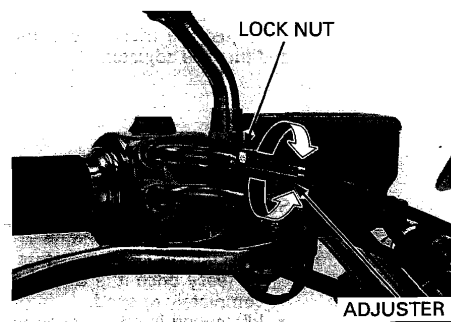
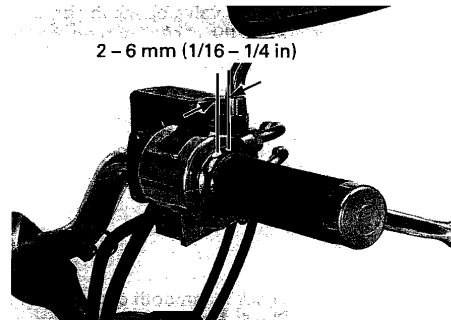

MAINTENANCE

Major adjustment is made with the lower adjuster.
Remove the air cleaner housing (page 6-6).
Loosen the lock nut, turn the adjuster as required.
Tighten the lock nut while holding the adjuster.
Recheck the throttle operation and install the air cleaner housing (page 6-7).

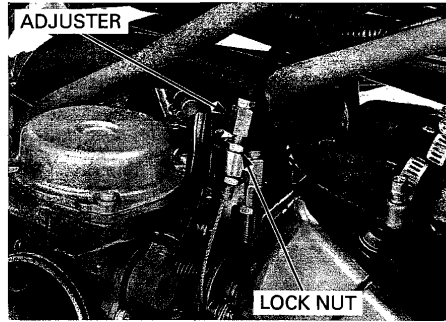

CHOKE OPERATION

This model's choke system uses a fuel enriching circuit controlled by a SE valve. The SE valve opens the enriching circuit via a cable when the choke knob on the left side of the frame is pulled out.

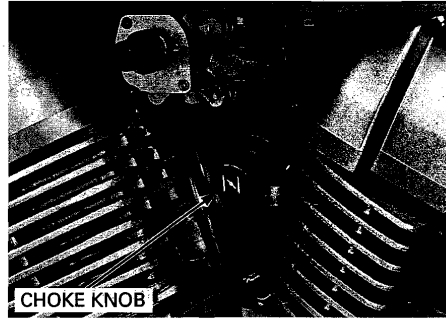

Check for smooth operation of the SE valve knob. Check for any deterioration or damage to the SE valve cable.

If the operation is not smooth, lubricate the SE valve cable and SE valve knob sliding surface with a commercially available cable lubricant or a light weight oil.

To adjust the friction, pull the rubber cover away and turn the adjuster.

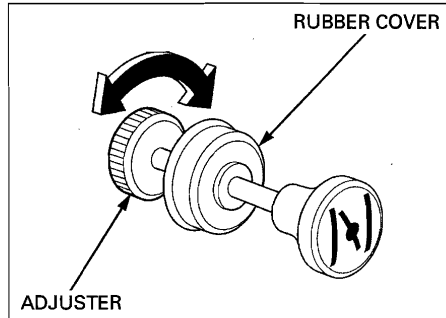

Starting enrichment system operation can be checked by the way the engine starts to runs:

- Difficulty in starting before the engine is warm up (easy once it is warmed up): SE valve is not completely opened.
- Idle speed is erratic even after warm-up (imperfect combustion): SE valve is not completely closed.

When the above symptoms occur, inspect the SE valve using the following procedure.

Remove the carburetor (page 6-7).

Loosen the SE valve nut and remove it from the carburetor.



Pull the SE valve knob all the way out to fully open position and recheck for smooth operation of the SE valve knob.
There should be no freeplay.

Check valve seat on the SE valve for damage.
Reinstall the SE valve in the reverse order of removal.

TORQUE:

SE valve nut: 2.3 N·m (0.2 kgf·m, 1.7 lbf·ft)

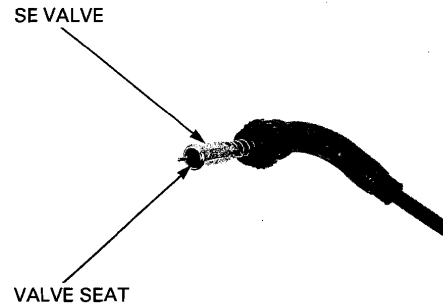

AIR CLEANER

NOTE:

- The viscous paper element type air cleaner can not be cleaned because the element contains a dust adhesive.
- If the motorcycle is used in usually wet or dusty areas, more frequent inspections are required.

Remove the socket bolts and air cleaner cover.



Remove the air cleaner element from the air cleaner housing.

Make sure that the O-ring is installed in position and is in good condition, and replace it with a new one if necessary.

Replace the air cleaner element in accordance with the maintenance schedule (page 4-4) or any time it is excessively dirty or damaged.

Install the removed parts in the reverse order of removal.

TORQUE:

Air cleaner cover socket bolt:
1.5 N·m (0.2 kgf·m, 1.1 lbf·ft)

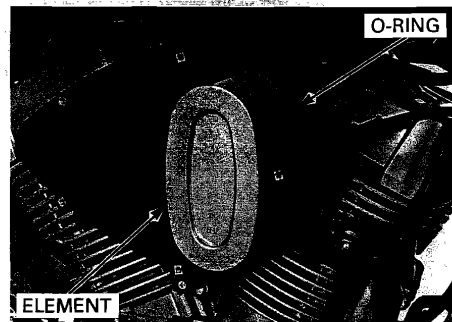

MAINTENANCE

SUB AIR CLEANER

Remove the left side cover (page 3-3).

Disconnect the air suction hoses and remove the sub air cleaners.

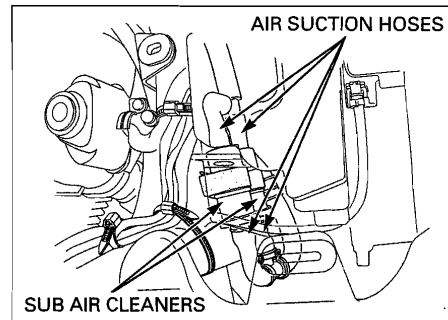

Replace the sub air cleaners in accordance with the maintenance schedule (page 4-4).

Install the sub air cleaners with the arrow mark facing down (PAIR control valve side) and connect the air suction hoses.

Install the left side cover (page 3-3).

SUB AIR CLEANER

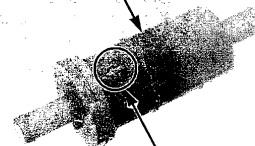

ARROW MARK

CRANKCASE BREATHER

NOTE:

Service more frequently when ridden in rain, at full throttle, or after the motorcycle is washed or overturned. Service if the deposit level can be seen in the drain plug.

Remove the drain plug from the air cleaner housing and drain the deposits into a suitable container, then reinstall the drain plug securely.

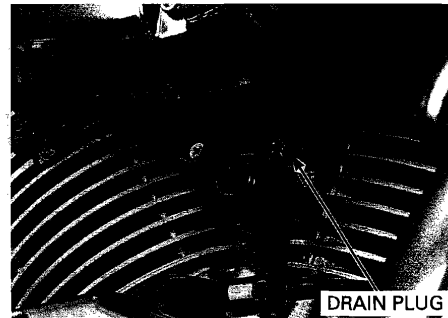

DRAIN PLUG

SPARK PLUG

REMOVAL

Disconnect the spark plug caps and clean around the spark plug bases.

NOTE:

Clean around the spark plug bases with compressed air before removing the spark plugs, and be sure that no debris is allowed to enter into the combustion chamber.

Remove the spark plugs.

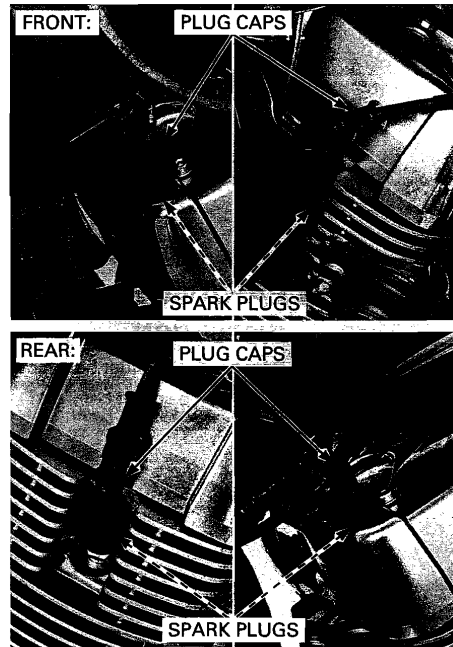

INSPECTION

Check the insulator for cracks or damage, and the electrodes for wear, fouling or discoloration. Replace each spark plug if necessary.

RECOMMENDED SPARK PLUG:

Standard:

DPR6EA-9 (NGK), X20EPR-U9 (DENSO)

For extended high speed riding:

DPR7EA-9 (NGK), X22EPR-U9 (DENSO)

Clean the spark plug electrodes with a wire brush or special plug cleaner.

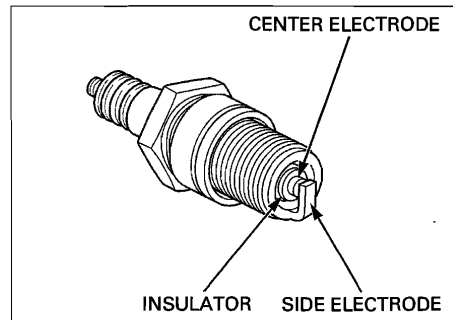

Check the spark plug gap between the center and side electrodes with a feeler gauge.

SPARK PLUG GAP: 0.8 – 0.9 mm (0.03 – 0.04 in)

If necessary, adjust the spark plug gap by bending the side electrode carefully.

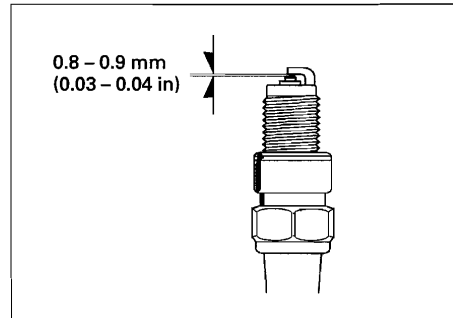

INSTALLATION

Install and hand tighten the spark plug to the cylinder head, then tighten the spark plug to the specified torque.

TORQUE: 18 N·m (1.8 kgf·m, 13 lbf·ft)

Connect the spark plug caps.

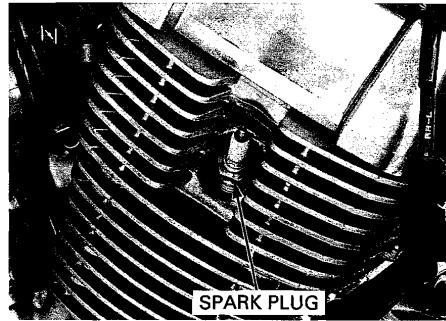

VALVE CLEARANCE

INSPECTION

Inspect and adjust the valve clearance while the engine is cold (below 35°C/95°F).

Remove the cylinder head cover (page 9-6).
Remove the socket bolts and alternator cover.

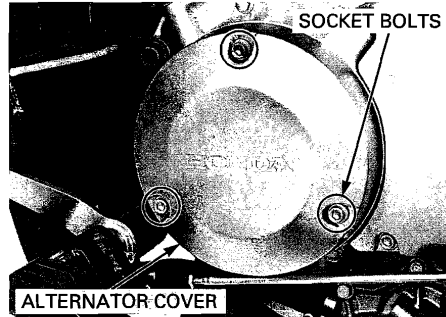

Remove the timing and crankshaft hole caps.

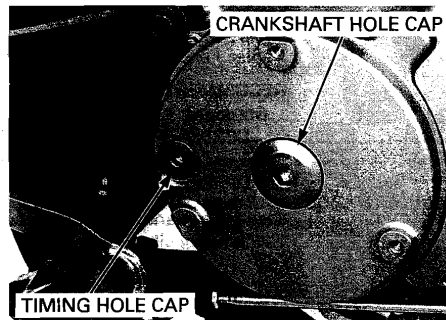

FRONT

Rotate the crankshaft counterclockwise and align the "FT" mark on the flywheel with the index notch on the left crankcase cover.

Make sure the piston is at TDC (Top Dead Center) on the compression stroke.

This position can be obtained by confirming that there is slack in the rocker arms. If there is no slack, rotate the crankshaft counterclockwise one full turn and align the "FT" mark with the index notch again.

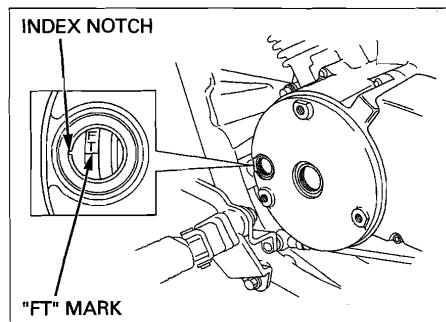

When checking the valve clearance, slide the feeler gauge from the center toward the outside.

Check the valve clearances by inserting a feeler gauge between the valve adjusting screw and valve stem.

VALVE CLEARANCES:

IN: 0.15 ± 0.02 mm (0.006 ± 0.001 in)
EX: 0.20 ± 0.02 mm (0.008 ± 0.001 in)

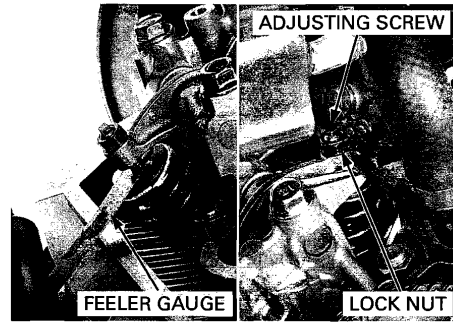

Adjust by loosening the valve adjusting screw lock nut and turning the adjusting screw until there is a slight drag on the feeler gauge.

TOOL:

Valve adjusting wrench **07908-KE90000 or 07908-KE90100 (U.S.A. only) with 10-mm offset box wrench**

Apply engine oil to the valve adjusting screw lock nut threads and seating surface.

Hold the valve adjusting screw and tighten the valve adjusting screw lock nut to the specified torque.

TORQUE: 23 N·m (2.3 kgf·m, 17 lbf·ft)

After tightening the valve adjusting screw lock nut, recheck the valve clearance.

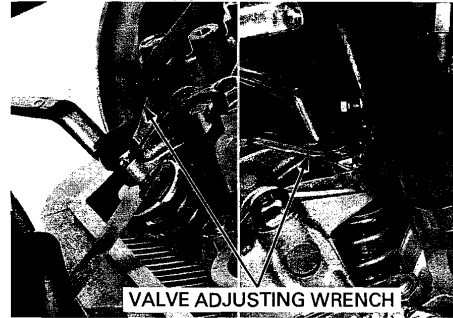

REAR

Rotate the crankshaft counterclockwise and align the "RT" mark on the flywheel with the index notch on the left crankcase cover. Make sure the piston is at TDC (Top Dead Center) on the compression stroke.

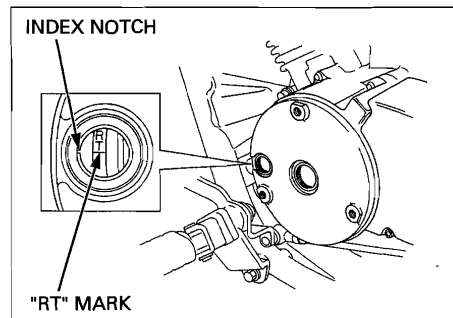

When checking the valve clearance, slide the feeler gauge from the center toward the outside.

Check the valve clearances by inserting a feeler gauge between the valve adjusting screw and valve stem.

VALVE CLEARANCES:

IN: 0.15 ± 0.02 mm (0.006 ± 0.001 in)
EX: 0.20 ± 0.02 mm (0.008 ± 0.001 in)

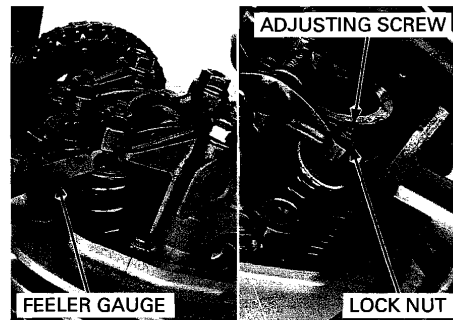

MAINTENANCE

Adjust by loosening the valve adjusting screw lock nut and turning the adjusting screw until there is a slight drag on the feeler gauge.

TOOL:

Valve adjusting wrench

07908-KE90000 or
07908-KE90100
(U.S.A. only) with
10-mm offset box
wrench

Apply engine oil to the valve adjusting screw lock nut threads and seating surface.

Hold the valve adjusting screw and tighten the valve adjusting screw lock nut to the specified torque.

TORQUE: 23 N-m (2.3 kgf-m, 17 lbf-ft)

After tightening the valve adjusting screw lock nut, recheck the valve clearance.

Coat new O-rings with engine oil and install them into the timing and crankshaft hole cap grooves. Apply grease to the timing and crankshaft hole cap threads.

Install the timing hole cap and tighten it to the specified torque.

TORQUE: 10 N-m (1.0 kgf-m, 7 lbf-ft)

Install the crankshaft hole cap and tighten it to the specified torque.

TORQUE: 15 N-m (1.5 kgf-m, 11 lbf-ft)

Install the alternator cover and tighten the socket bolts to the specified torque.

TORQUE: 10 N-m (1.0 kgf-m, 7 lbf-ft)

Install the cylinder head cover (page 9-31).

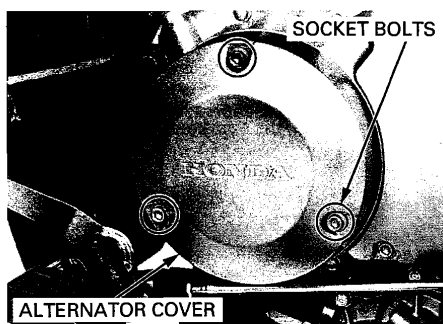
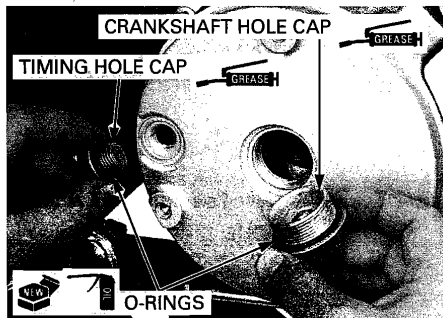
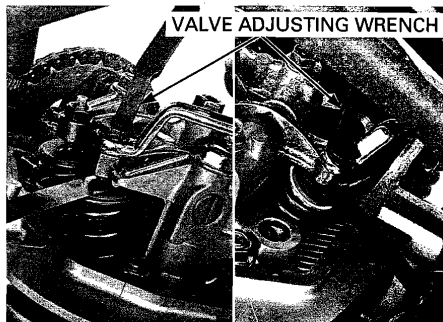

ENGINE OIL

OIL LEVEL CHECK

Start the engine, and let it idle for 3 – 5 minutes.
Stop the engine and wait 2 – 3 minutes.
Hold the motorcycle in an upright position.

Remove the oil filler cap/dipstick and wipe the oil from the dipstick with a clean cloth.
Insert the dipstick without screwing it in, remove it and check the oil level.

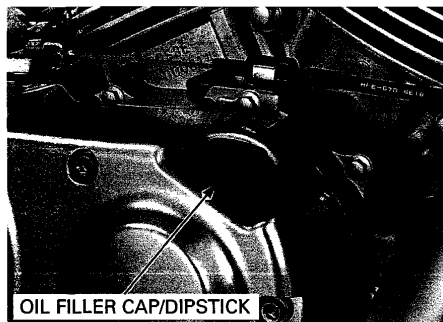

If the oil level is below or near the lower level mark on the dipstick, add the recommended oil to the upper level mark.

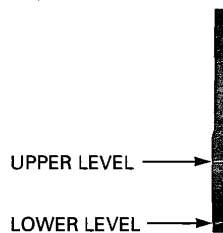

RECOMMENDED ENGINE OIL:

Pro Honda GN4 4-stroke oil (U.S.A. and Canada) or equivalent motor oil
API service classification: SG or higher
JASO T 903 standard: MA
Viscosity: SAE 10W-30

NOTE:

Other viscosities shown in the chart may be used when the average temperature in your riding area is within the indicated range.

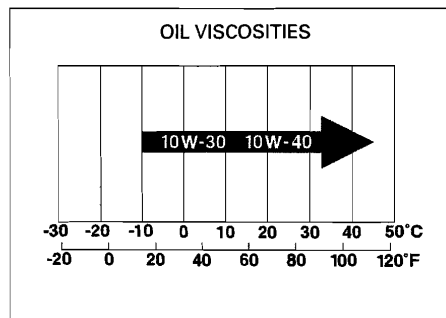

Check that the O-ring is in good condition, replace it if necessary.

Coat the O-ring with engine oil and install it. Reinstall the oil filler cap/dipstick.

For engine oil change (page 4-13).

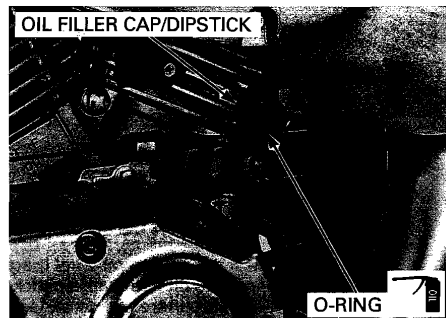

ENGINE OIL FILTER

NOTE:

Change the oil with engine warm and the motorcycle on its sidestand to assure complete and rapid draining.

Start the engine, warm it up and stop it.

Remove the oil filler cap/dipstick (page 4-12). Remove the oil drain bolt, sealing washer and drain the oil.

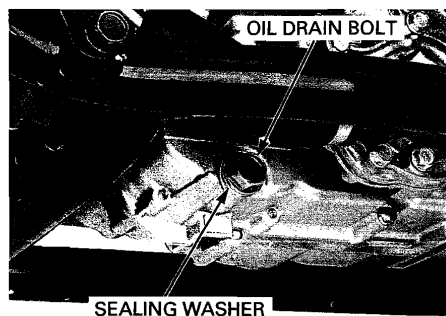

MAINTENANCE

Remove the oil filter cartridge using the special tool and let the remaining oil drain out.

TOOL:

Oil filter wrench

**07HAA-PJ70101 or
07HAA-PJ70100
(U.S.A. only) or
07HAA-PLCA100
(U.S.A. only)**

OIL FILTER WRENCH

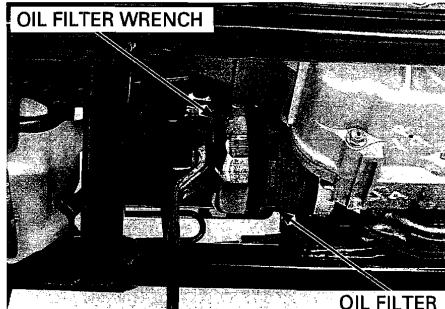

OIL FILTER

Coat a new O-ring with engine oil and install it to a new oil filter cartridge. Apply engine oil to the threads of a new oil filter cartridge.

Install the oil filter cartridge and tighten it to the specified torque.

TOOL:

Oil filter wrench

**07HAA-PJ70101 or
07HAA-PJ70100
(U.S.A. only) or
07HAA-PLCA100
(U.S.A. only)**

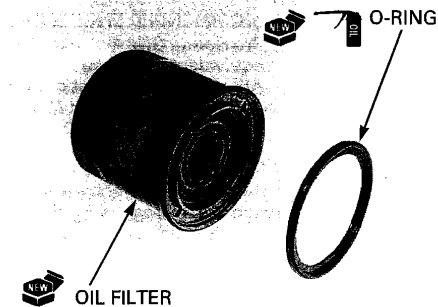

TORQUE: 26 N·m (2.7 kgf·m, 19 lbf·ft)

Install the oil drain bolt with a new sealing washer and tighten it to the specified torque.

TORQUE: 29 N·m (3.0 kgf·m, 21 lbf·ft)

Fill the crankcase with the recommended engine oil (page 4-13).

OIL CAPACITY:

**2.5 liters (2.6 US qt, 2.2 Imp qt) at draining
2.6 liters (2.7 US qt, 2.3 Imp qt) at oil filter change
3.2 liters (3.4 US qt, 2.8 Imp qt) at disassembly**

Check the engine oil level (page 4-12).
Install the oil filler cap/dipstick (page 4-13).
Make sure there are no oil leaks.

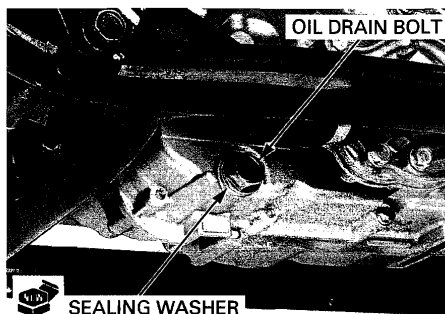

ENGINE IDLE SPEED

NOTE:

- Inspect and adjust the idle speed after all other engine maintenance items have been performed and are within specifications.
- The engine must be warm for accurate idle speed inspection and adjustment.

Connect a tachometer according to its manufacturer's instructions.

Warm up the engine, shift the transmission into neutral and hold the motorcycle in an upright position.

Check the idle speed.

IDLE SPEED: 1,200 ± 100 rpm

If the adjustment is necessary, turn the throttle stop screw knob as required.



RADIATOR COOLANT

Check the coolant level of the reserve tank.

The level should be between the "UPPER" and "LOWER" level lines with the motorcycle in an upright position.

If the level is low, remove the reserve tank cap, and fill the tank to the "UPPER" level line with a 1 : 1 mixture of distilled water and antifreeze (coolant preparation: page 7-6).

RECOMMENDED ANTIFREEZE:

Pro Honda HP coolant or an equivalent high quality ethylene glycol antifreeze containing silicate-free corrosion inhibitors.

Check to see if there are any coolant leaks when the coolant level decreases very rapidly.

If the reserve tank becomes completely empty, there is a possibility of air getting into the cooling system. Be sure to remove any air from the cooling system (page 7-7).

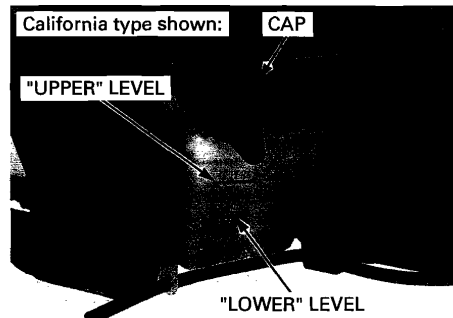

COOLING SYSTEM

Check the radiator air passage for clogs or damage.

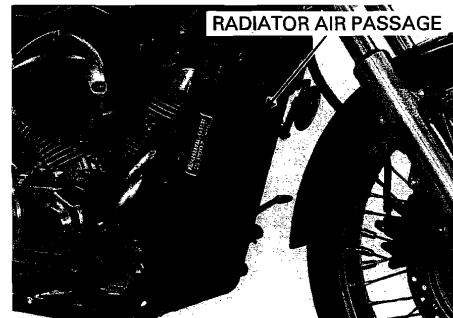

MAINTENANCE

Straighten bent fins with a small, flat blade screwdriver and remove insects, mud or other obstructions with compressed air or low pressure water. Replace the radiator if the air flow is restricted over more than 20% of the radiating surface.

For radiator replacement (page 7-11).

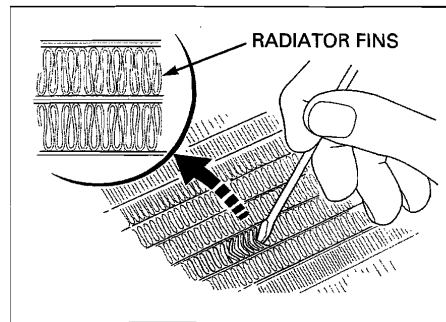

Remove the steering side covers (page 3-5).

Check for any coolant leakage from the water pump, water hoses and hose joints.

Check the radiator hoses for cracks or deterioration and replace if necessary.

Check that all water hose bands are tight (page 7-10).

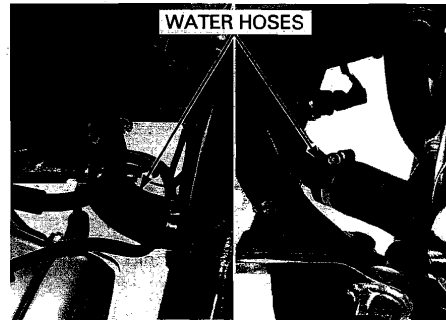

SECONDARY AIR SUPPLY SYSTEM

- This model is equipped with a built-in secondary air supply system. The pulse secondary air supply system is located on the cylinder head covers.
- The secondary air supply system introduces filtered air into exhaust gases in the exhaust port. The secondary air is drawn into the exhaust port whenever there is negative pressure pulse in the exhaust system. This charged secondary air promotes burning of the unburned exhaust gases and changes a considerable amount of hydrocarbons and carbon monoxide into relatively harmless carbon dioxide and water.

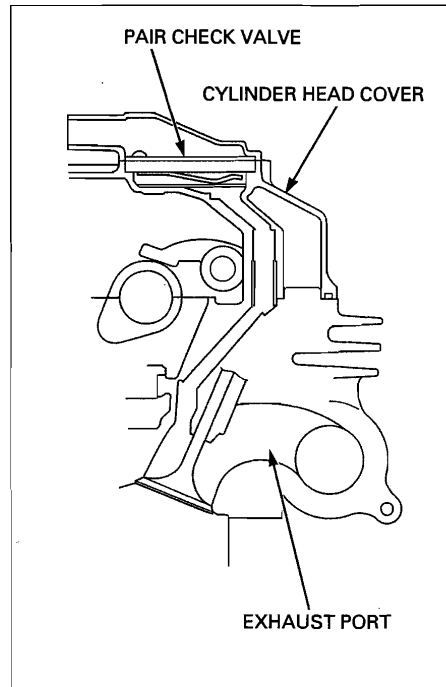

If the hoses show any signs of heat damage, inspect the PAIR check valves in the cylinder head covers for damage (page 6-29).

Remove the fuel tank (page 3-4).

Check the PAIR (pulse secondary air injection) air supply hoses between the PAIR control valve and cylinder head cover for deterioration, damage or loose connections. Make sure that the hoses are not cracked.

Check the air suction hose between the sub air cleaner and PAIR control valve for deterioration, damage or loose connections. Make sure that the hoses are not kinked, pinched or cracked.

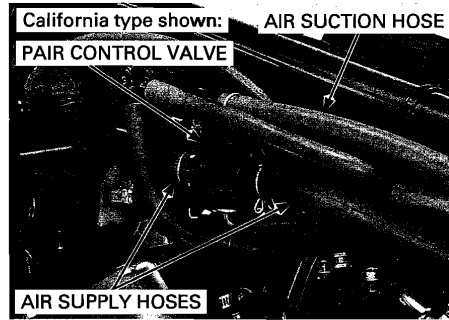

EVAP CONTROL SYSTEM (California type only)

Check the EVAP canister for cracks or damage.

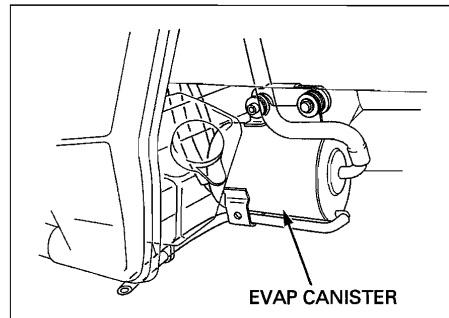

Remove the following:

- Steering side covers (page 3-5)
- Fuel tank (page 3-4)

Check the hoses between the fuel tank, EVAP canister, EVAP purge control valve, EVAP CAV control valve and carburetor for deterioration, damage or loose connections. Also check that the hoses are not kinked or pinched.

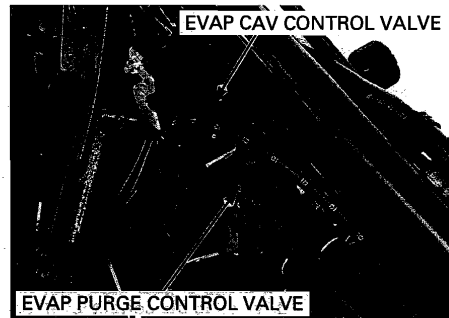

Remove the bolt and pull the sub air cleaner box out with the stay.

Remove the sub air cleaner cover and check the sub air cleaner filter for contamination or damage.

Replace the sub air cleaner filter if necessary.

Install the removed parts in the reverse order of removal.

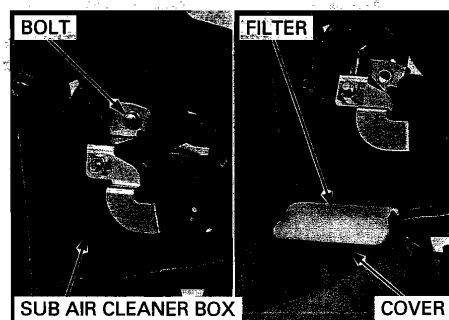

FINAL DRIVE OIL

OIL LEVEL CHECK

Place the motorcycle on its sidestand on a level surface.

Remove the oil filler cap from the final gear case.

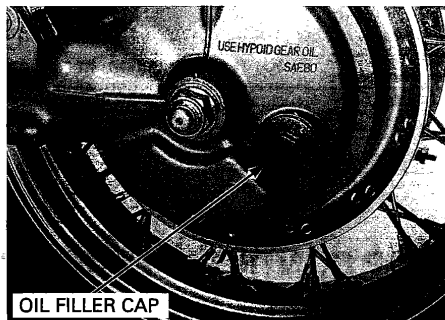

OIL FILLER CAP

Check that the oil level is up to the lower edge of the oil filler hole.

Check for leaks if the oil level is low. Fill the recommended final drive oil through the oil filler hole until it reaches the lower edge of the hole.

RECOMMENDED FINAL DRIVE OIL:

Hypoid gear oil, SAE #80

Coat a new O-ring with oil and install it onto the oil filler cap.

Install and tighten the oil filler cap to the specified torque.

TORQUE: 12 N·m (1.2 kgf·m, 9 lbf·ft)

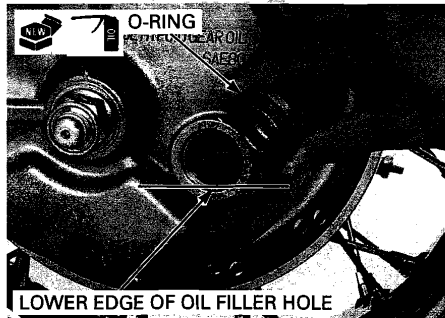

LOWER EDGE OF OIL FILLER HOLE

OIL CHANGE

Support the motorcycle securely and raise the rear wheel off the ground.

Remove the oil filler cap, drain bolt and sealing washer from the final gear case, slowly turn the rear wheel and drain the oil.

After the oil is completely drained, install the drain bolt with a new sealing washer and tighten it to the specified torque.

TORQUE: 12 N·m (1.2 kgf·m, 9 lbf·ft)

Fill the final gear case with the recommended final drive oil to the correct level (page 4-18).

OIL CAPACITY:

160 cm³ (5.4 US oz, 5.6 Imp oz) at draining

170 cm³ (5.7 US oz, 6.0 Imp oz) at disassembly

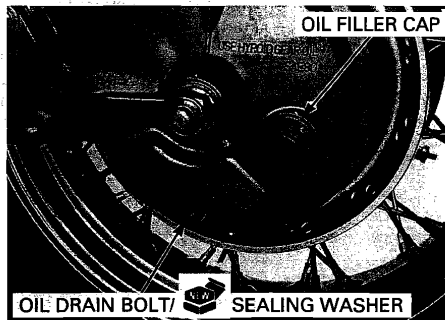

OIL FILLER CAP

OIL DRAIN BOLT / SEALING WASHER

BRAKE FLUID

NOTICE

Spilled fluid can damage painted, plastic or rubber parts. Place a rag over these parts whenever the system is serviced.

- Do not mix different types of fluid, as they are not compatible with each other.
- Do not allow foreign material to enter the system when filling the reservoir.

NOTE:

- When the fluid level is low, check the brake pads for wear (page 4-20).
- A low fluid level may be due to wear of the brake pads. If the brake pads are worn and the caliper pistons are pushed out, this accounts for a low reservoir level. If the brake pads are not worn and the fluid level is low, check the entire system for leaks (page 4-20).

Turn the handlebar to the left side so the reservoir is level and check the front brake reservoir fluid level through the sight glass.

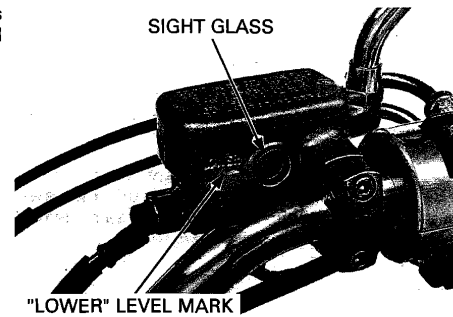

If the fluid level is near the "LOWER" level mark, remove the screws, reservoir cap, set plate and diaphragm.

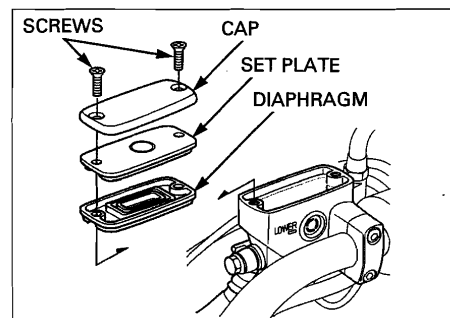

Fill the reservoir with DOT 4 brake fluid from a sealed container to the casting ledge.

Install the diaphragm, set plate and reservoir cap, then tighten the cap screws to the specified torque.

TORQUE: 1.5 N·m (0.2 kgf·m, 1.1 lbf·ft)

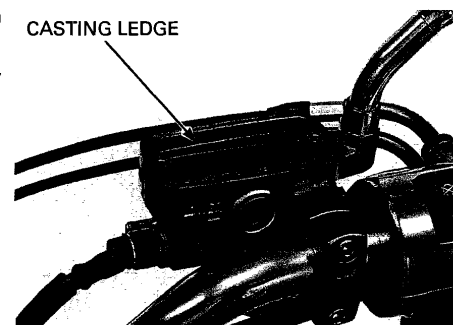

BRAKE SHOES/PADS WEAR

FRONT BRAKE PADS

Check the brake pad for wear.

Always replace the brake pads as a set to assure even disc pressure.

Replace the brake pads if either pad is worn to the wear limit groove.

For brake pad replacement (page 17-7).

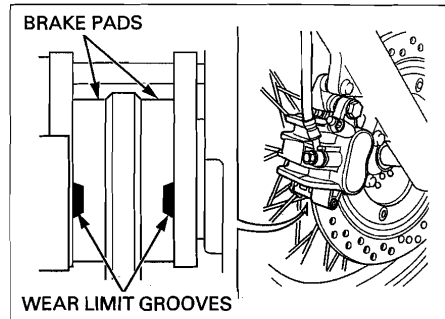

REAR BRAKE SHOES

Check the indicator plate position when the brake pedal applied.

If the arrow on the indicator plate aligns with the "Δ" mark, inspect the brake drum (page 16-14).

If the brake drum I.D. is within the service limit, replace the brake shoes (page 16-15).

NOTE:

If no adjustment remains before the wear indicator limit is reached, this indicates excessive wear and the brake shoes need to be replaced.

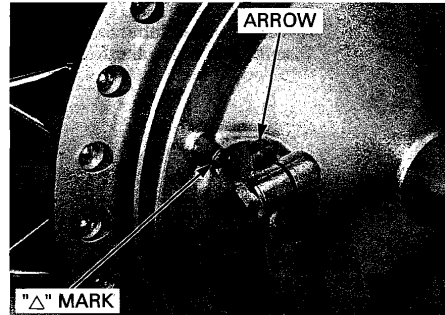

BRAKE SYSTEM

Firmly apply the brake lever, and check that no air has entered the system.

If the lever feels soft or spongy when operated, bleed the air from the system.

For air bleeding procedures (page 17-5).

Inspect the brake hose and fittings for deterioration, cracks, damage or signs of leakage.

Tighten any loose fittings.

Replace the hose and fittings as required.

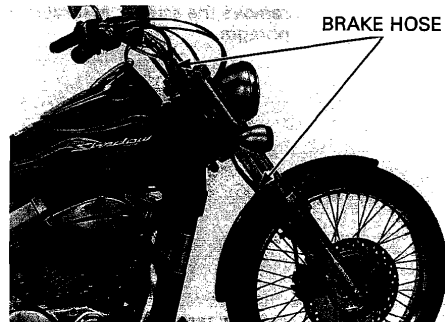

BRAKE PEDAL HEIGHT

Check the brake pedal height.

BRAKE PEDAL HEIGHT:

75 mm (3.0 in) above the top of the footpeg

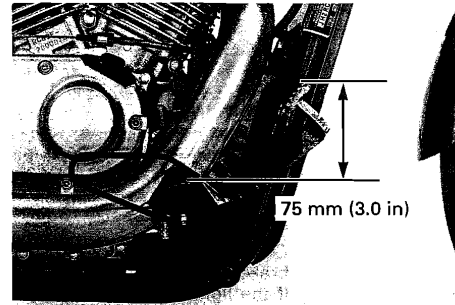

To adjust:

Loosen the lock nut and turn the stopper bolt as required.

Tighten the lock nut securely.

After adjusting the brake pedal height, check the following:

- Brake pedal freeplay (page 4-21)
- Rear brake light switch operation (page 4-22)

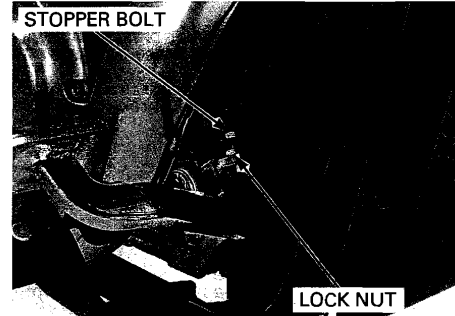

BRAKE PEDAL FREEPLAY

NOTE:

Perform brake pedal freeplay adjustment after adjusting brake pedal height.

Check the brake pedal freeplay.

FREEPLAY: 20 – 30 mm (13/16 – 1-3/16 in)

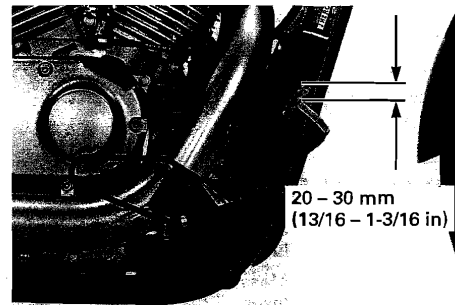

Make sure the cut-out on the adjusting nut is seated on the joint pin.

If necessary, adjust the brake pedal freeplay by turning the adjusting nut.

NOTE:

After adjusting the brake pedal freeplay, check the rear brake light switch operation (page 4-22).

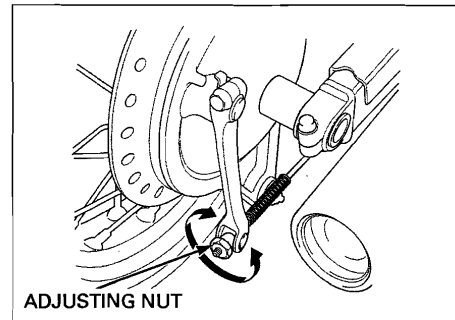

BRAKE LIGHT SWITCH

NOTE:

- The brake light switch on the front brake master cylinder cannot be adjusted. If the front brake light switch actuation and brake engagement are not synchronized, either replace the switch unit or the malfunctioning parts of the system.
- Make the rear brake light switch adjustments after the brake pedal height adjustment and the brake pedal freeplay adjustment have been made.

Check that the brake light comes on just prior to the brake actually being engaged. If the light fails to come on, adjust the rear brake light switch so that the light comes on at the proper time.

Do not turn the switch body while turning the adjusting nut.

Hold the rear brake light switch body and turn the adjusting nut as required.

Recheck the rear brake light switch operation.

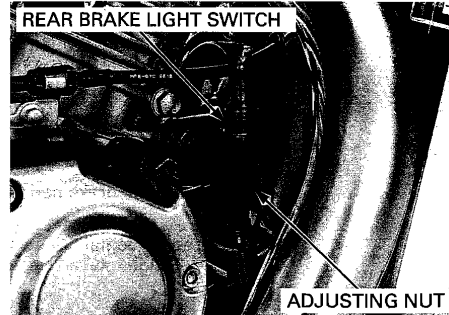

HEADLIGHT AIM

Hold the motorcycle in an upright position.

Adjust the headlight beam as specified by local laws and regulations.

Adjust vertically by turning the vertical adjusting screw.

Adjust horizontally by turning the horizontal adjusting screw.

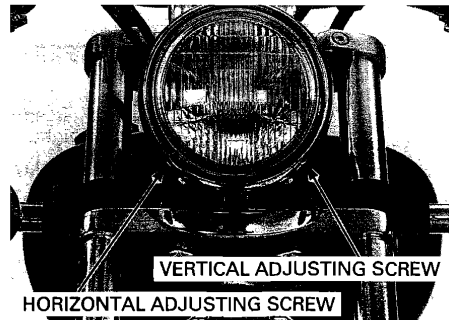

CLUTCH SYSTEM

Inspect the clutch cable for kinks or damage, and lubricate the cable if necessary.

Measure the clutch lever freeplay at the end of the lever.

FREEPLAY: 10 – 20 mm (3/8 – 13/16 in)

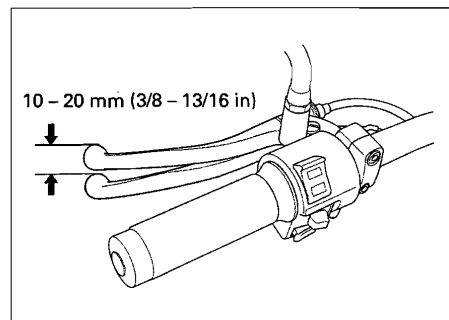

The adjuster may be damaged if it is positioned too far out, leaving minimal thread engagement.

Minor adjustment is made with the upper adjuster at the clutch lever.
 Loosen the lock nut and turn the adjuster as required.
 Tighten the lock nut while holding the adjuster.
 If the adjuster is threaded out near its limit and the correct freeplay cannot be obtained, turn the adjuster all the way in and back out one turn.
 Tighten the lock nut and make major adjustment (page 4-23).

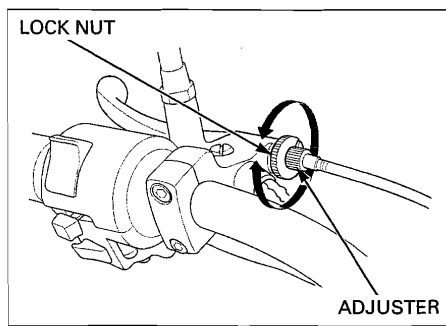

Major adjustment is made with the lower adjusting nut at the engine.
 Loosen the lock nut and turn the adjusting nut as required.
 After adjustment is complete, tighten the lock nut while holding the adjusting nut.
 Check the clutch operation.
 If the freeplay cannot be obtained, or the clutch slips during the test ride, disassemble and inspect the clutch (page 11-7).

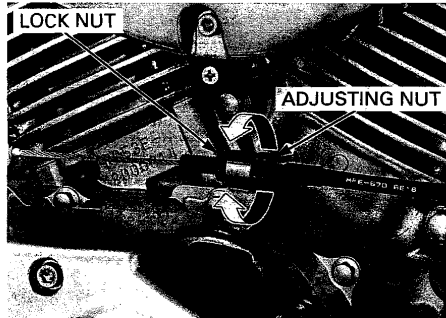

SIDESTAND

Hold the motorcycle in an upright position.
 Check the sidestand spring for damage or loss of tension.
 Check the sidestand assembly for freedom of movement and lubricate the sidestand pivot if necessary.
 Check the sidestand ignition cut-off system:

- Sit astride the motorcycle and raise the sidestand.
- Start the engine with the transmission in neutral, then shift the transmission into gear, while squeezing the clutch lever.
- Fully lower the sidestand.
- The engine should stop as the sidestand is lowered.

If there is a problem with the system, check the sidestand switch (page 21-20).

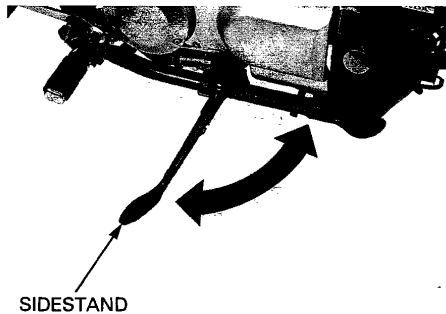

SUSPENSION

FRONT SUSPENSION INSPECTION

Check the action of the forks by applying the front brakes and compressing the front suspension several times.
Check the entire assembly for leaks, damage or loose fasteners.
Replace damaged components which cannot be repaired.
Tighten all nuts and bolts.
For fork service (page 15-19).

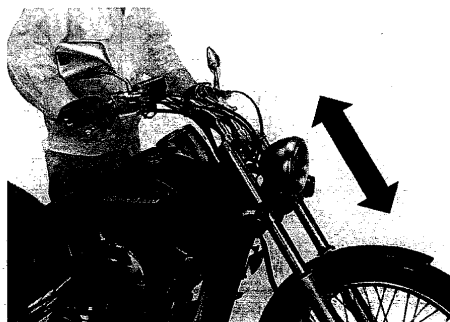

REAR SUSPENSION INSPECTION

Check the action of the shock absorbers by compressing them several times.
Check the entire shock absorber assembly for leaks, damage or loose fasteners.
Replace damaged components which cannot be repaired.
Tighten all nuts and bolts.
For shock absorber service (page 16-21).

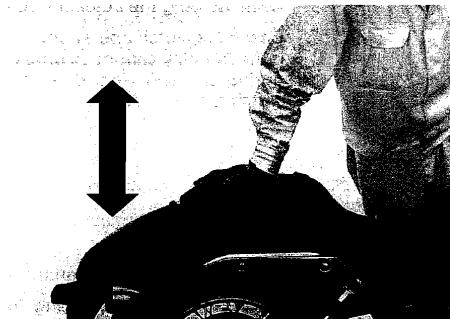

Support the motorcycle securely and raise the rear wheel off the ground.
Check for worn swingarm bearings by grabbing the rear wheel and attempting to move the wheel side to side.
Replace the bearings if any looseness is noted (page 16-22).

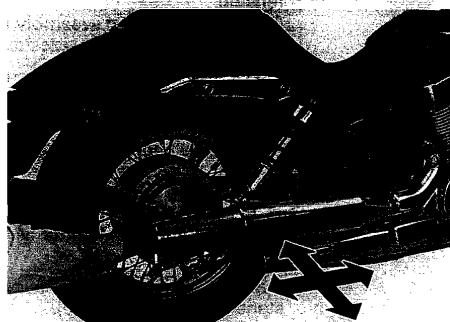

NUTS, BOLTS, FASTENERS

Check that all chassis nuts and bolts are tightened to their correct torque values (page 1-13).
Check that all cotter pins, safety clips, hose clamps and cable stays are in place and properly secured.

WHEELS/TIRES

Support the motorcycle securely and raise the front wheel off the ground.
Hold the front fork leg and move the front wheel sideways forcefully to see if the wheel bearings are worn.

For front wheel service (page 15-13).

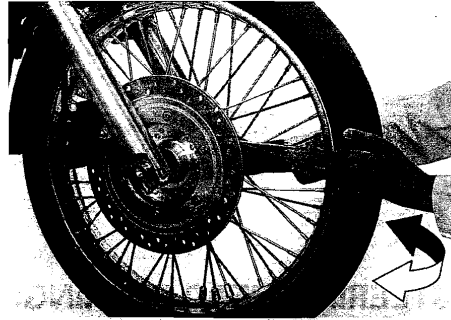

Support the motorcycle securely and raise the rear wheel off the ground.
Hold the swingarm and move the rear wheel sideways with the force to see if the wheel bearings are worn.

For rear wheel service (page 16-6).

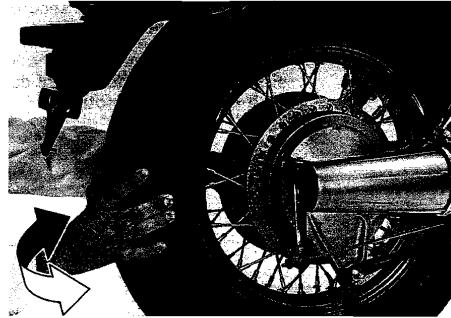

Inspect the spokes for looseness by tapping them with a screwdriver.

Tap on the spokes and be sure that the same clear metallic sound can be heard on all spokes.

If a spoke does not sound clearly, or if it sounds different from the other spokes, tighten it to the specified torque.

TOOL:
Spoke wrench **07JMA-MR60100**

TORQUE: 4.2 N-m (0.4 kgf-m, 3.1 lbf-ft)

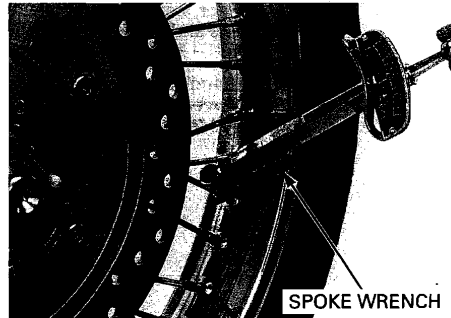

Check the tire pressure with a tire pressure gauge when the tires are cold.

RECOMMENDED TIRE PRESSURE:

- Up to 90 kg (200 lbs) load:
 - Front: 200 kPa (2.00 kgf/cm², 29 psi)
 - Rear: 200 kPa (2.00 kgf/cm², 29 psi)
- Up to maximum weight capacity:
 - Front: 200 kPa (2.00 kgf/cm², 29 psi)
 - Rear: 250 kPa (2.50 kgf/cm², 36 psi)

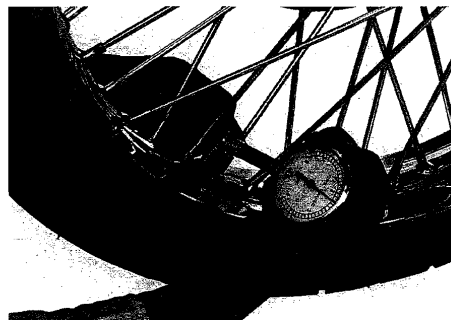

MAINTENANCE

Check the tires for cuts, embedded nails, or other damage.

Check the front and rear wheels for trueness.

Measure the tread depth at the center of the tires.

Replace the tires when the tread depth reaches the following limits.

MINIMUM TIRE TREAD DEPTH:

Front: 1.5 mm (0.06 in)

Rear: 2.0 mm (0.08 in)

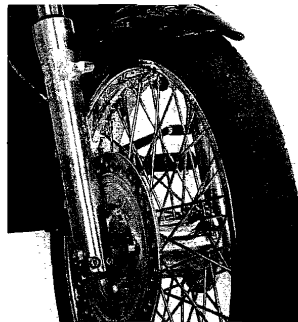

STEERING HEAD BEARINGS

Support the motorcycle securely and raise the front wheel off the ground.

Check that the handlebar moves freely from side to side. Make sure the control cables do not interfere with the handlebar rotation.

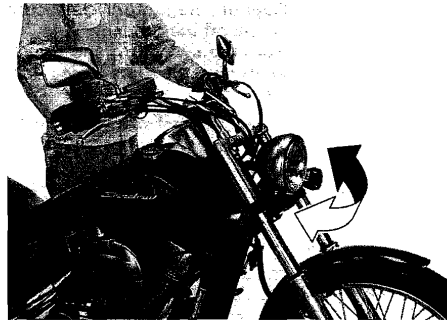

Check for steering stem bearings by grabbing the fork legs and attempting to move the front fork side to side.

If the handlebar moves unevenly, binds, or has vertical movement, inspect the steering head bearings (page 15-28).

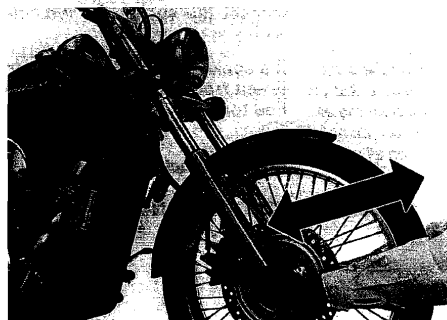

5. LUBRICATION SYSTEM

LUBRICATION SYSTEM DIAGRAM	5-2	OIL PRESSURE INSPECTION	5-5
SERVICE INFORMATION	5-3	OIL PUMP	5-6
TROUBLE SHOOTING	5-4		

LUBRICATION SYSTEM DIAGRAM

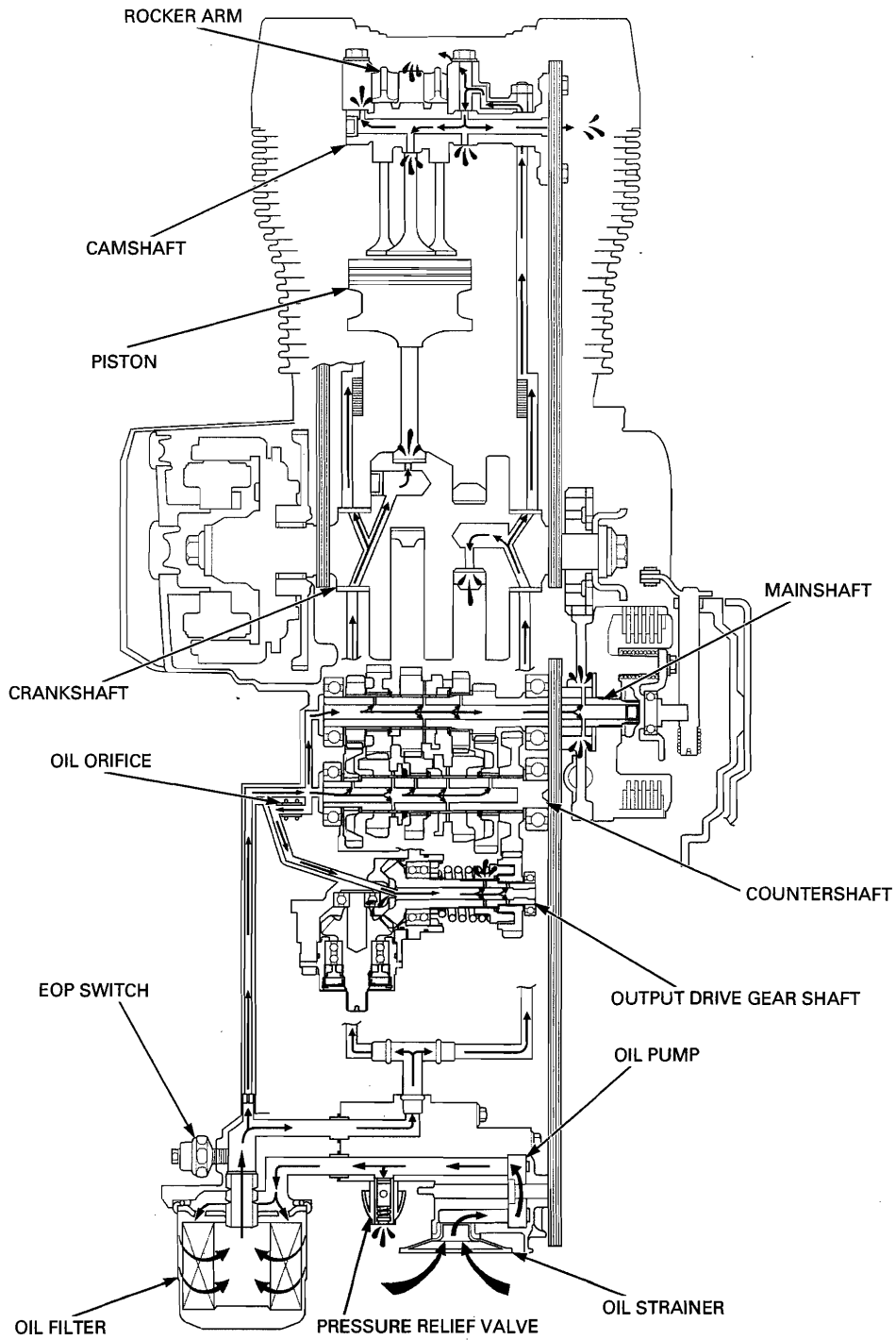

SERVICE INFORMATION**GENERAL****▲ CAUTION**

Used engine oil may cause skin cancer if repeatedly left in contact with the skin for prolonged periods. Although this is unlikely unless you handle used oil on a daily basis, it is still advisable to thoroughly wash your hands with soap and water as soon as possible after handling used oil.

- The crankcase must be separated to service the oil pump.
- When removing and installing the oil pump, use care not to allow dust or dirt to enter the engine.
- If any portion of the oil pump is worn beyond the specified service limits, replace the oil pump as an assembly.
- After the oil pump has been installed, check that oil pressure is correct.
- For engine oil level check (page 4-12).
- For engine oil and filter change (page 4-13).
- For oil pressure indicator inspection (page 21-15).

SPECIFICATIONS

ITEM		STANDARD	SERVICE LIMIT
Engine oil capacity	At draining	2.5 liters (2.6 US qt, 2.2 Imp qt)	-
	At oil filter change	2.6 liters (2.7 US qt, 2.3 Imp qt)	-
	At disassembly	3.2 liters (3.4 US qt, 2.8 Imp qt)	-
Recommended engine oil		Pro Honda GN4 4-stroke oil (U.S.A. and Canada) or equivalent motor oil API service classification: SG or higher JASO T 903 standard: MA Viscosity: SAE 10W-30	-
Oil pressure at EOP switch		530 kPa (5.4 kgf/cm ² , 77 psi) at 5,000 rpm/(80°C/176°F)	-
Oil pump rotor	Tip clearance	0.15 (0.006)	0.20 (0.008)
	Body clearance	0.15 – 0.21 (0.006 – 0.008)	0.35 (0.014)
	Side clearance	0.02 – 0.08 (0.001 – 0.003)	0.10 (0.004)

TORQUE VALUES

EOP switch	12 N·m (1.2 kgf·m, 9 lbf·ft)	Apply sealant to the threads
EOP switch terminal screw	1.9 N·m (0.2 kgf·m, 1.4 lbf·ft)	
Oil pump assembly bolt	13 N·m (1.3 kgf·m, 10 lbf·ft)	

TOOLS

Oil pressure gauge set
07506-3000001

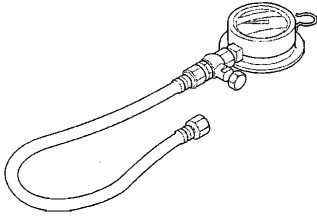

or equivalent commercially available in U.S.A. (Gauge set MT37A)

Oil pressure gauge attachment
07510-4220100

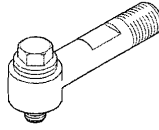

or equivalent commercially available in U.S.A. (Adaptor AT77AH)

TROUBLE SHOOTING

Oil level too low

- Oil consumption
- External oil leak
- Worn piston rings
- Improperly installed piston rings
- Worn cylinders
- Worn stem seals
- Worn valve guide

Low oil pressure

- Oil level low
- Clogged oil strainer
- Faulty oil pump
- Internal oil leak
- Incorrect oil being used

No oil pressure

- Oil level too low
- Oil pressure relief valve stuck open
- Broken oil pump drive chain
- Broken oil pump drive and/or driven sprocket
- Damaged oil pump
- Internal oil leak

High oil pressure

- Oil pressure relief valve stuck closed
- Clogged oil gallery or metering orifice
- Incorrect oil being used

Oil contamination

- Oil or filter not changed often enough
- Worn piston rings

Oil emulsification

- Blown cylinder head gasket
- Leaky coolant passage
- Entry of water

OIL PRESSURE INSPECTION

Remove the left crankcase rear cover (page 3-5).

If the engine is cold, the pressure reading will be abnormally high. Warm up the engine to normal operating temperature before starting this test. Stop the engine.

Remove the rubber cap and disconnect the EOP switch wire by removing the terminal screw.

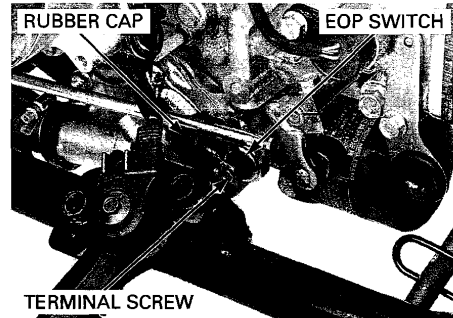

Remove the EOP switch and connect an oil pressure gauge attachment and gauge to the EOP switch hole.

TOOLS:

Oil pressure gauge set 07506-3000001
 Oil pressure gauge attachment 07510-4220100
 (or equivalent commercially available in U.S.A.,
 gauge set MT37A and adaptor AT77AH)

Check the oil level and add the recommended engine oil if necessary (page 4-12).

Start the engine and check the oil pressure at 5,000 rpm.

OIL PRESSURE:

530 kPa (5.4 kgf/cm², 77 psi) at 5,000 rpm
 (80°C/176°F)

Stop the engine.

Do not apply sealant to the thread head 3 – 4 mm (0.1 – 0.2 in).

Apply sealant to the EOP switch threads as shown and tighten it to the specified torque.

TORQUE: 12 N·m (1.2 kgf·m, 9 lbf·ft)

Connect the EOP switch wire and tighten the terminal screw to the specified torque.

TORQUE: 1.9 N·m (0.2 kgf·m, 1.4 lbf·ft)

Install the rubber cap.

Start the engine.

Check that the oil pressure indicator turns off after 1 or 2 seconds. If the oil pressure indicator stays on, stop the engine immediately and determine the cause (page 21-15).

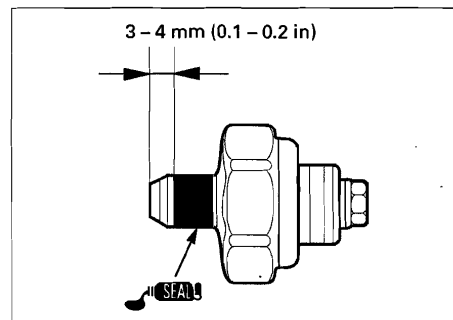
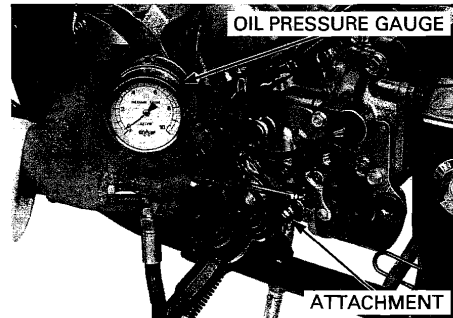

OIL PUMP

REMOVAL

Separate the crankcase (page 13-9).

Remove the bolts and oil pump assembly from the left crankcase.

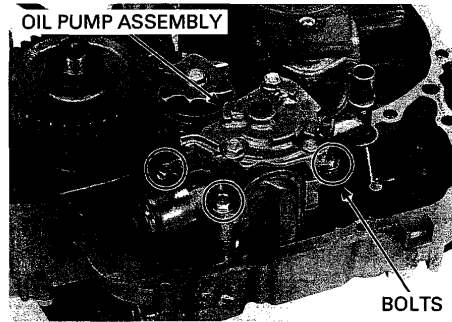

Remove the dowel pin, collars and O-rings.

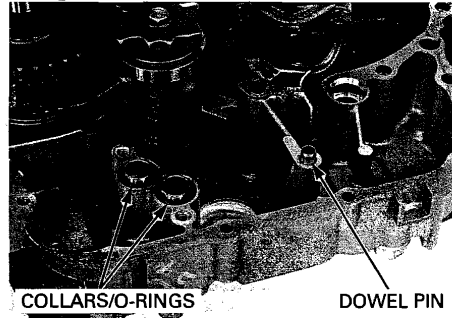

DISASSEMBLY

OIL PUMP BODY

Remove the oil pipe, oil pipe seal and O-ring.

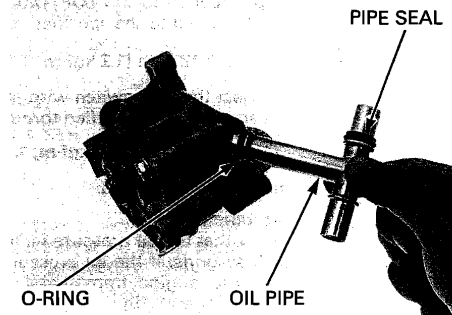

Remove the pressure relief valve and O-ring.

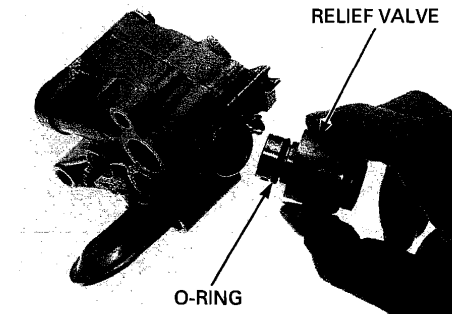

Remove the oil strainer and gasket.

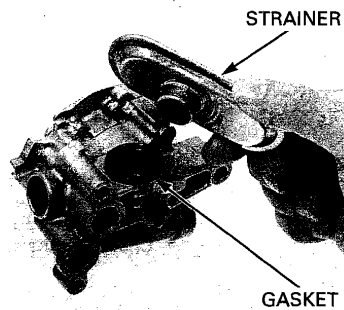

Remove the assembly bolts and pump body from the pump cover.

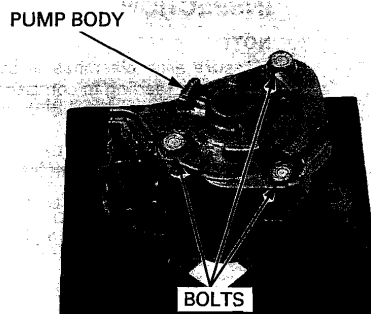

Remove the dowel pins. Remove the washer, drive shaft, drive pin, inner and outer rotors.

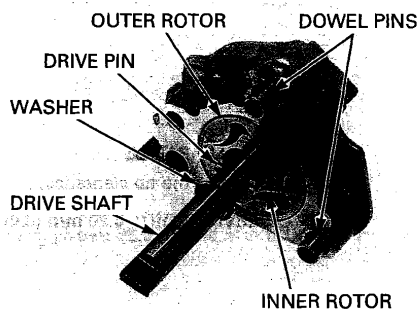

PRESSURE RELIEF VALVE

Check the operation of the pressure relief valve by pushing on the piston.

The snap ring is under spring pressure. Use care when removing it and wear eye and face protection. Be careful not to lose the disassembled parts.

Remove the snap ring, washer, spring and piston from the pressure relief valve body.

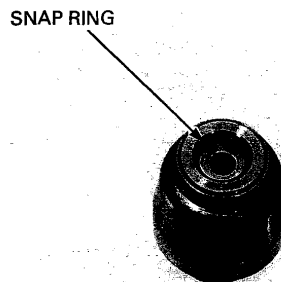

LUBRICATION SYSTEM

Check the piston for wear, sticking or damage.
Check the valve spring for wear or fatigue.
Check the relief valve body for clogging or damage.

Clean all parts and assemble the relief valve in the reverse order of disassembly.

NOTE:

- Install the snap ring with the chamfered edge facing the thrust load side.
- Do not reuse worn snap ring which could easily spin in the groove.
- Check that the snap ring is seated in the groove.

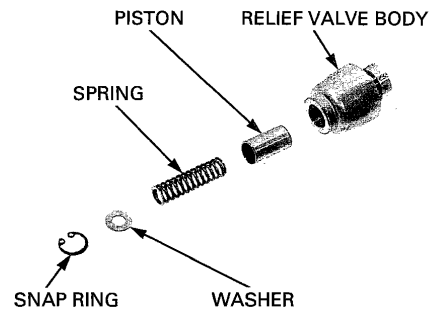

INSPECTION

NOTE:

Measure each clearance at several points and use the largest reading to compare the service limit.

BODY CLEARANCE

Temporarily assemble the inner rotor, outer rotor, drive pin and pump shaft into the pump body.

Measure the body clearance.

SERVICE LIMIT: 0.35 mm (0.014 in)

BODY CLEARANCE:

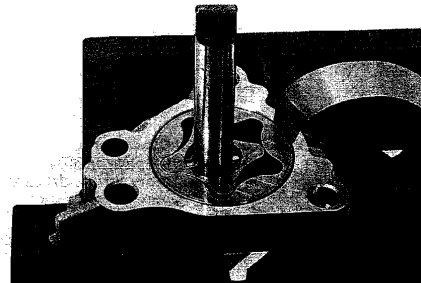

TIP CLEARANCE

Measure the tip clearance.

SERVICE LIMIT: 0.20 mm (0.008 in)

TIP CLEARANCE:

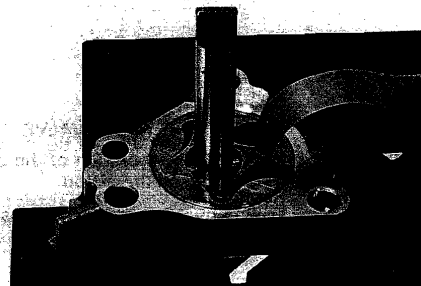

SIDE CLEARANCE

Measure the side clearance.

SERVICE LIMIT: 0.10 mm (0.004 in)

SIDE CLEARANCE:

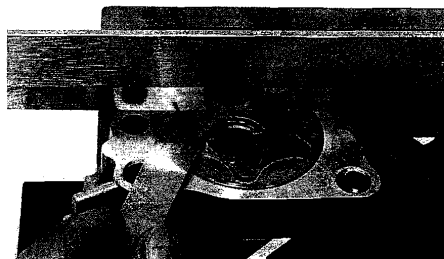

OIL PUMP ASSEMBLY

Dip all parts in clean engine oil.

13 N·m (1.3 kgf·m, 10 lbf·ft)

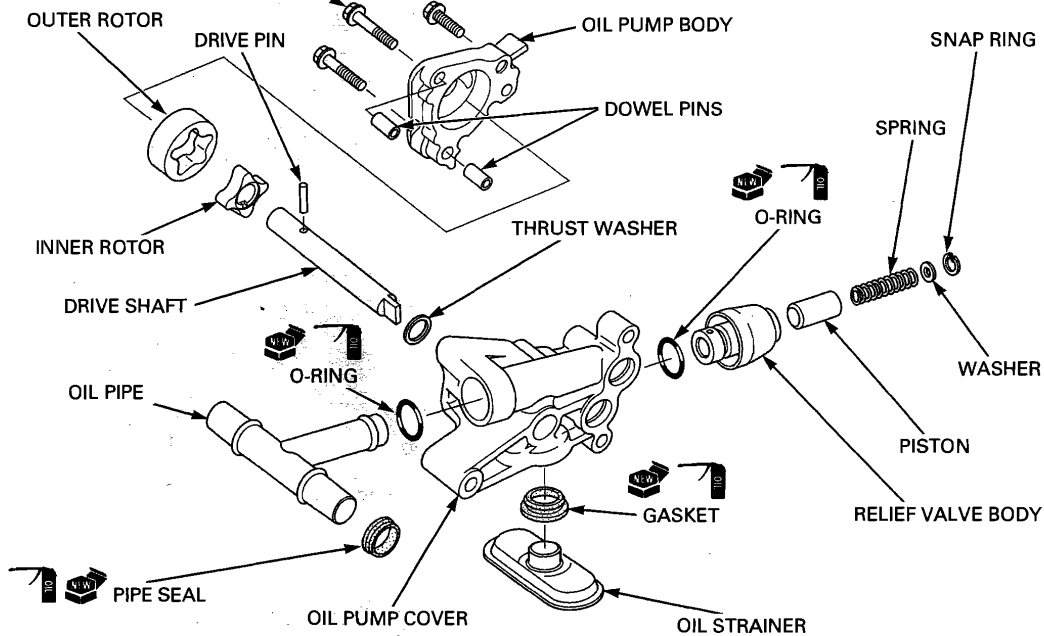

Install the outer and inner rotors to the pump body.

NOTE:
Install the inner rotor with the groove side facing the pump cover.

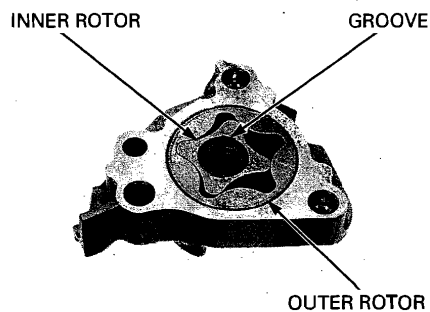

LUBRICATION SYSTEM

Install the drive shaft and drive pin by aligning the drive pin with the grooves in the inner rotor.

Place the washer into the inner rotor groove.
Install the dowel pins to the pump body.

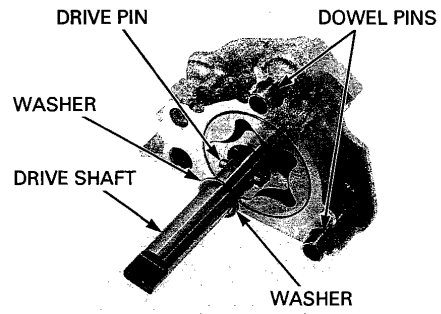

Install the pump cover on the pump body.
Install and tighten the assembly bolts to the specified torque.

TORQUE: 13 N·m (1.3 kgf·m, 10 lbf·ft)

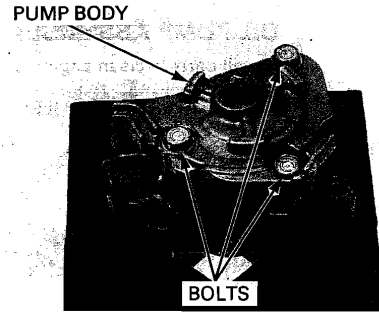

Clean the oil strainer.

Coat a new gasket with engine oil and install it to the pump body.
Install the oil strainer to the pump cover by aligning its side end with the groove on the pump cover.

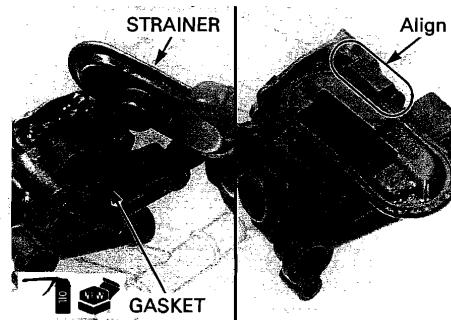

Coat a new O-ring with engine oil and install it to the pressure relief valve.

Install the pressure relief valve into the pump cover.

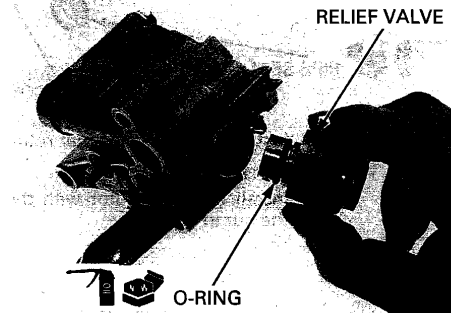

Coat a new oil pipe seal and new O-ring with engine oil, then install them to the oil pipe.

NOTE:
Install an O-ring with its tapered side facing out.
Install the oil pipe to the pump cover securely.

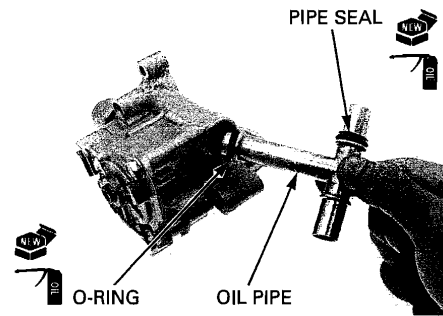

INSTALLATION

Install the dowel pin and collars.
Coat new O-rings with engine oil and install them.

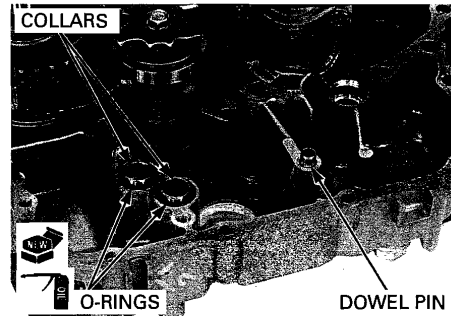

Install the oil pump assembly into the crankcase securely.

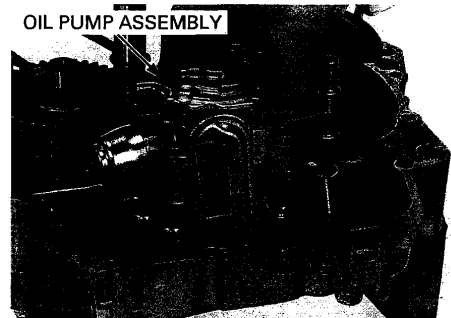

Install and tighten the bolts securely.
Assemble the crankcase (page 13-49).
Check the oil pressure (page 5-5).

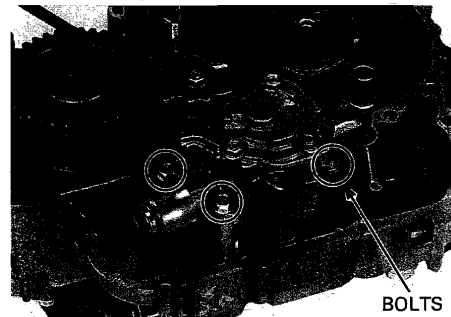

COMPONENT LOCATION	6-2	CARBURETOR INSTALLATION	6-21
SERVICE INFORMATION	6-3	INTAKE MANIFOLD	6-23
TROUBLESHOOTING	6-4	PILOT SCREW ADJUSTMENT	6-25
AIR CLEANER HOUSING	6-6	HIGH ALTITUDE ADJUSTMENT	6-26
CARBURETOR REMOVAL.....	6-7	SECONDARY AIR SUPPLY SYSTEM	6-28
CARBURETOR DISASSEMBLY/ INSPECTION	6-9	EVAP CONTROL SYSTEM (California type only)	6-30
CARBURETOR ASSEMBLY	6-15		

COMPONENT LOCATION

27 N·m (2.8 kgf·m, 20 lbf·ft)

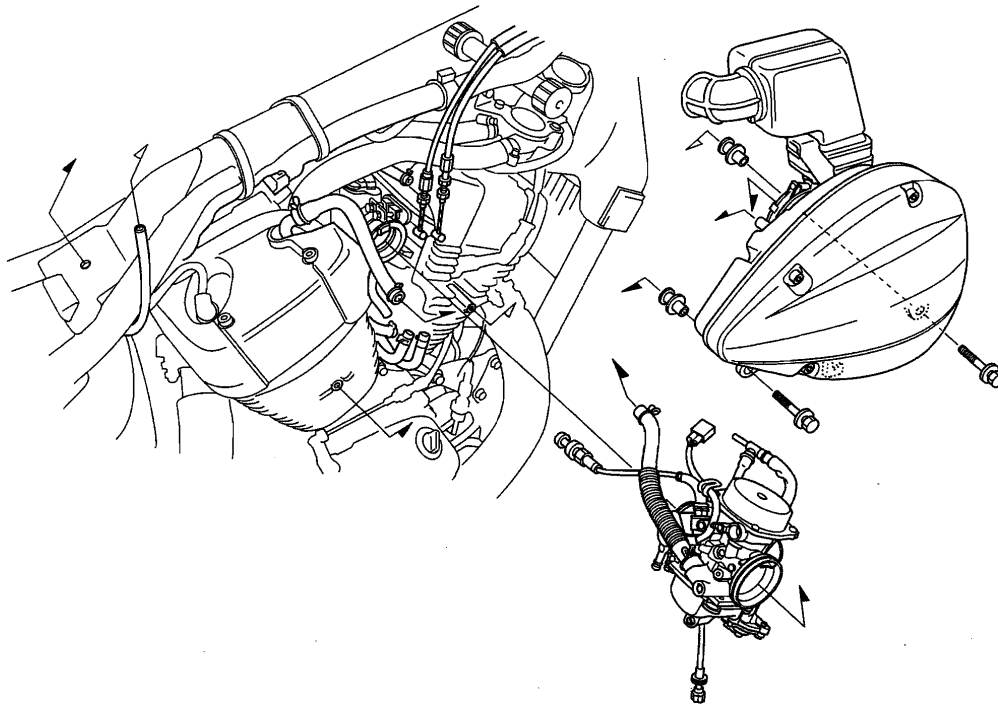
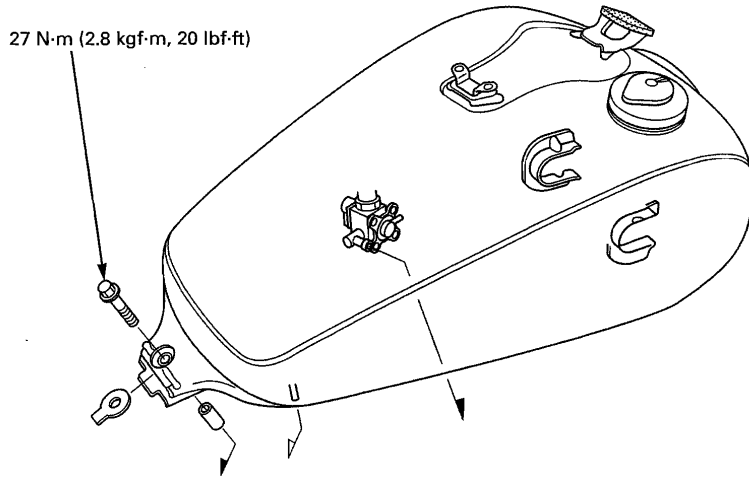

SERVICE INFORMATION

GENERAL

- Work in a well ventilated area. Smoking or allowing flames or sparks in the work area or where gasoline is stored can cause a fire or explosion.
- Bending or twisting the control cable will impair smooth operation and could cause the cable to stick or bind, resulting in loss of vehicle control.
- For fuel tank removal and installation (page 3-4).
- Before disassembling the carburetor, place an approved fuel container under the float chamber, loosen the drain screw and drain the float chamber.
- After removing the intake manifold, cover the intake ports of the cylinder heads with shop towels to prevent any foreign material from dropping into the engine.
- Be sure to remove the diaphragms before cleaning air and fuel passages with compressed air. The diaphragm might be damaged.
- When disassembling the fuel system parts, note the locations of the O-rings. Replace them with new ones on reassembly.
- If the vehicle is to be stored for more than 1 month, drain the float chamber. Fuel left in the float chamber may clog jets, resulting in hard starting or poor driveability.
- For TP sensor inspection (page 19-10).

SPECIFICATIONS

ITEM		SPECIFICATIONS
Carburetor identification number	49 states/Canada type	VE5EA
	California type	VE5EB
Main jet	Standard	#122
	High altitude	#120
Slow jet		#50
Pilot screw	Initial/final opening	See page 6-25
High altitude adjustment		See page 6-26
Float level		18.5 mm (0.73 in)
Engine idle speed		1,200 ± 100 rpm
Throttle grip freeplay		2 – 6 mm (1/16 – 1/4 in)

TORQUE VALUES

Air cleaner chamber connecting tube band screw	0.7 N·m (0.1 kgf·m, 0.5 lbf·ft)
Air cleaner cover socket bolt	1.5 N·m (0.2 kgf·m, 1.1 lbf·ft)
PAIR check valve cover bolt	7 N·m (0.7 kgf·m, 5.2 lbf·ft)
Air cleaner chamber stay mounting screw	1.1 N·m (0.1 kgf·m, 0.8 lbf·ft)
Vacuum chamber cover screw	2.1 N·m (0.2 kgf·m, 1.5 lbf·ft)
TP sensor torx screw	3.4 N·m (0.3 kgf·m, 2.5 lbf·ft)
Carburetor heater set plate screw	3.4 N·m (0.3 kgf·m, 2.5 lbf·ft)
Float chamber screw	2.1 N·m (0.2 kgf·m, 1.5 lbf·ft)
Accelerator pump cover screw	2.1 N·m (0.2 kgf·m, 1.5 lbf·ft)
Air cut-off valve cover screw	2.1 N·m (0.2 kgf·m, 1.5 lbf·ft)
Accelerator pump link mounting bolt	3.4 N·m (0.3 kgf·m, 2.5 lbf·ft)
SE valve nut	2.3 N·m (0.2 kgf·m, 1.7 lbf·ft)
Carburetor drain screw	1.5 N·m (0.2 kgf·m, 1.1 lbf·ft)
Slow jet	1.8 N·m (0.2 kgf·m, 1.3 lbf·ft)
Needle jet holder	2.3 N·m (0.2 kgf·m, 1.7 lbf·ft)
Main jet	2.1 N·m (0.2 kgf·m, 1.5 lbf·ft)

FUEL SYSTEM

TOOLS

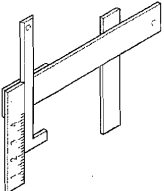
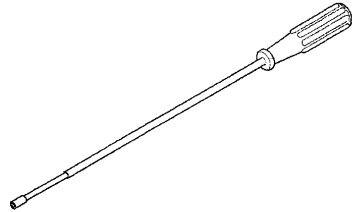
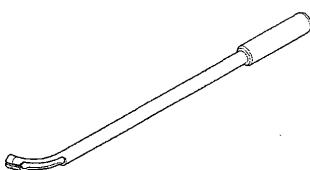
<p>Carburetor float level gauge 07401-0010000</p>  <p>A carburetor float level gauge, consisting of a vertical ruler with a horizontal crossbar and a float mechanism.</p>	<p>Pilot screw wrench 07KMA-MS60102</p>  <p>A long, thin pilot screw wrench with a handle and a pointed tip.</p> <p>or 07MMA-MT3010B (U.S.A. only)</p>	<p>Pilot screw elbow guide 07PMA-MZ20110</p>  <p>A pilot screw elbow guide, which is a long, thin rod with a curved end.</p> <p>or 07PMA-MZ2011A (U.S.A. only)</p>
---	---	--

TROUBLESHOOTING

Engine cranks but won't start

- No fuel in tank
- No fuel to carburetor
 - Clogged fuel strainer
 - Clogged fuel line
 - Clogged fuel tank breather hose
- Too much fuel getting to the engine
 - Clogged air cleaner
 - Flooded carburetor
- Intake air leak
- Contaminated/deteriorated fuel
- Clogged SE valve circuit
- Improper SE valve operation
- Improper throttle operation
- No spark at plug (faulty ignition system – page 19-5)

Lean mixture

- Clogged fuel jets
- Faulty float valve
- Float level too low
- Restricted fuel line
- Clogged carburetor air vent hose
- Restricted fuel tank breather hose
- Intake air leak
- Faulty vacuum piston
- Faulty EVAP control system (California type only)
 - Faulty EVAP CAV control valve
 - Clogged hose of the EVAP CAV system

Rich mixture

- SE valve open (ON)
- Clogged air jets
- Faulty float valve
- Float level too high
- Dirty air cleaner
- Worn jet needle or needle jet
- Faulty vacuum piston
- Faulty EVAP control system (California type only)
 - Faulty EVAP purge control valve
 - Clogged hose of the EVAP purge system

Engine stalls, hard to start, rough idling

- Restricted fuel line
- Fuel mixture too lean/rich
- Contaminated/deteriorated fuel
- Intake air leak
- Misadjusted idle speed
- Misadjusted pilot screw
- Misadjusted float level
- Restricted fuel tank breather hose
- Clogged air cleaner
- Clogged slow circuit
- Clogged SE valve circuit
- Faulty EVAP control system (California type only)
 - Faulty EVAP CAV control valve
 - Faulty EVAP purge control valve
 - Clogged hose of the EVAP control system
- Faulty ignition system (page 19-5)

Afterburn when engine braking is used

- Lean mixture in slow circuit
- Faulty air cut-off valve
- Faulty PAIR system
 - Faulty PAIR control valve
- Improper PAIR control valve for high altitude riding (page 6-26)
- Faulty ignition system (page 19-5)

Backfiring or misfiring during acceleration

- Lean mixture
- Faulty ignition system (page 19-5)
- Faulty accelerator pump

Poor performance (driveability) and poor fuel economy

- Clogged fuel system
- Faulty EVAP control system (California type only)
 - Faulty EVAP CAV control valve
 - Clogged hose of the EVAP CAV system
- Faulty ignition system (page 19-5)

AIR CLEANER HOUSING

REMOVAL

Remove the fuel tank (page 3-4).
Remove the throttle stop screw knob from the air cleaner housing stay.
Remove the air cleaner housing mounting bolts and collars.

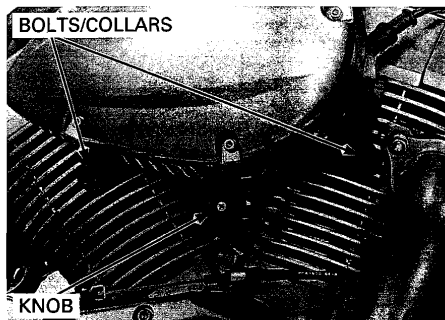

Disconnect the crankcase breather hose from the air cleaner housing.
Loosen the air cleaner housing connecting tube band screw.
Remove the air cleaner housing.

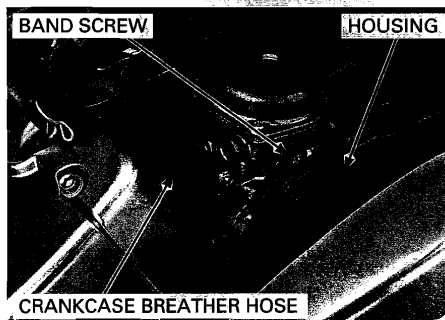

DISASSEMBLY/ASSEMBLY

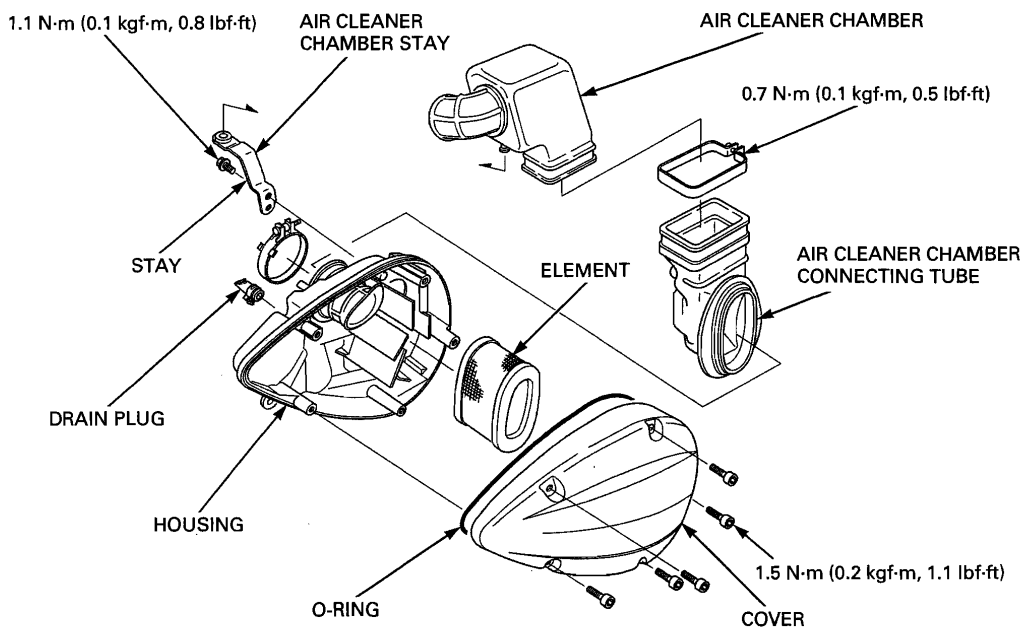

INSTALLATION

Connect the crankcase breather hose to the air cleaner housing.
 Connect the connecting tube to the carburetor.
 Tighten the air cleaner housing connecting tube band screw securely.

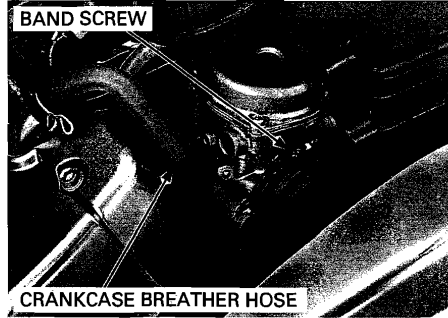

Install the collars, air cleaner housing mounting bolts, and tighten the mounting bolts securely.
 Install the throttle stop screw knob onto the air cleaner housing stay.
 Install the fuel tank (page 3-4).

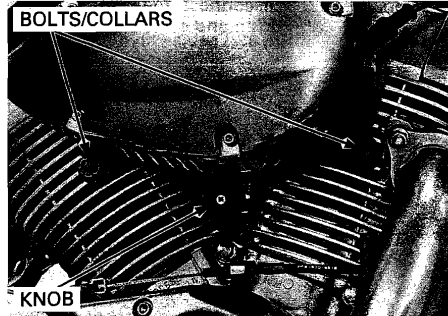

CARBURETOR REMOVAL

Remove the following:

- Fuel tank (page 3-4)
- Air cleaner housing (page 6-6)

Disconnect the PAIR control valve vacuum hose from the 3-way joint.
 Disconnect the TP sensor 3P connector.

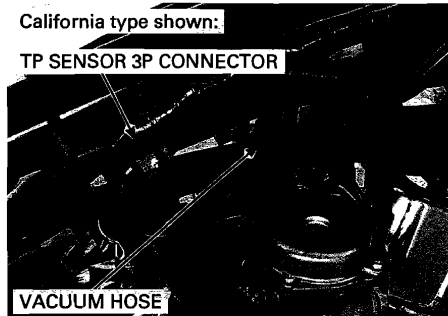

Connect the drain hose to the float chamber.
 Loosen the carburetor drain screw and drain the gasoline to the approved gasoline container.
 Retighten the carburetor drain screw to the specified torque.
TORQUE: 1.5 N-m (0.2 kgf-m, 1.1 lbf-ft)
 Disconnect the drain hose.

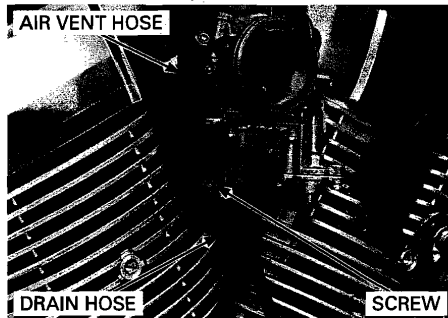

Except california type: Release the carburetor air vent hose from the clamp.

FUEL SYSTEM

Loosen the insulator band screw (carburetor side) and disconnect the carburetor from the insulator.

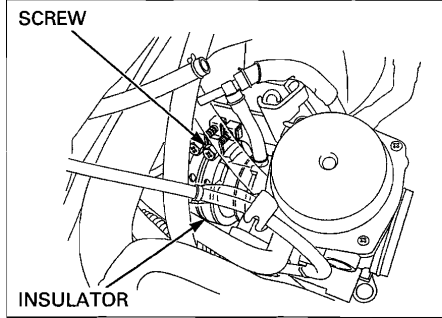

Loosen the lock nuts all the way.
Disconnect the throttle cables from the throttle drum and cable stays.

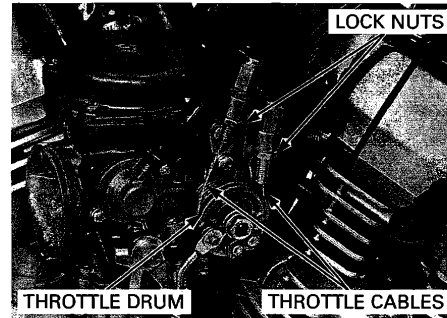

Disconnect the carburetor air vent (California type: fuel cut-off solenoid valve) hose from the carburetor.

California type only: Disconnect the EVAP purge control valve hose (to throttle bore).

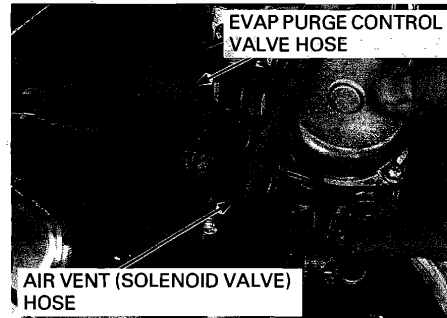

Clamp the water hoses and disconnect them.

California type only: Disconnect the EVAP purge control valve vacuum hose.

Remove the carburetor.

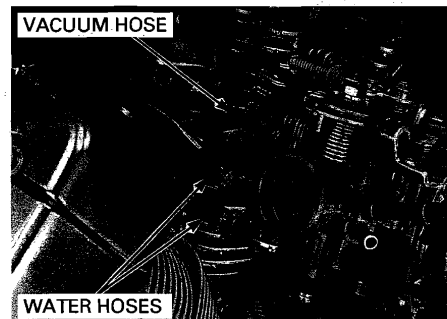

CARBURETOR DISASSEMBLY/ INSPECTION

Remove the PAIR control valve vacuum hoses and fuel hose from the carburetor.

VACUUM HOSES

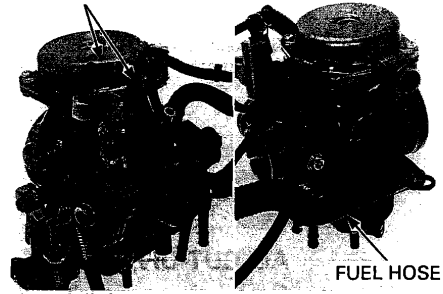

SE VALVE

Loosen the SE valve nut and remove the SE valve from the carburetor.

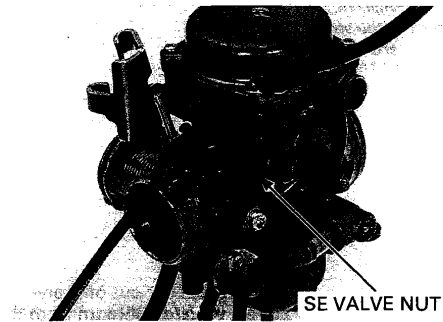

CARBURETOR FUEL STRAINER

Remove the fuel strainer from the carburetor.
Check the strainer for clog or damage.
Replace the strainer if necessary.

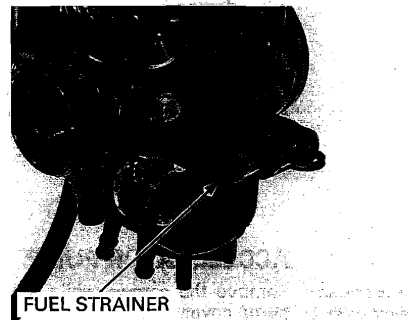

TP SENSOR

Release the TP sensor wire from the clamp.
Remove the torx screw, TP sensor and O-ring.

NOTE:
Do not remove the TP sensor unless it is necessary to replace it or disassemble the carburetor. For sensor inspection (page 19-10).

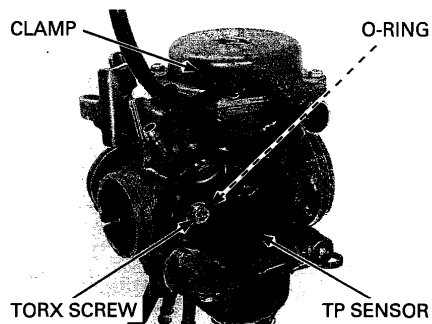

AIR CUT-OFF VALVE

The air cut-off valve cover is under spring pressure. Do not lose the spring and screws.

Remove the screws while holding the air cut-off valve cover.

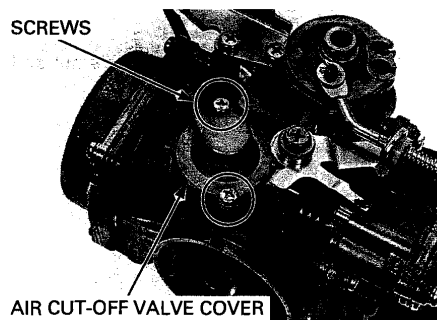

Remove the air cut-off valve cover, spring and air cut-off valve/diaphragm from the carburetor body.

Check the diaphragm for pin holes, deterioration or other damage.
Check the air cut-off valve for wear or damage at the tip.
Check the orifice in the air cut-off valve cover and carburetor body for clog or restriction.
Air will leak out of the vacuum chamber if the diaphragm is damaged in any way, even with just a pin hole.

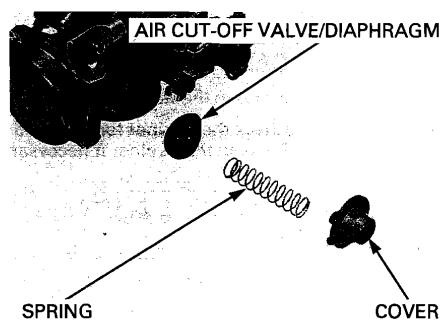

ACCELERATOR PUMP

The accelerator pump cover is under spring pressure. Do not lose the spring and screws.

Remove the screws while holding the accelerator pump cover.

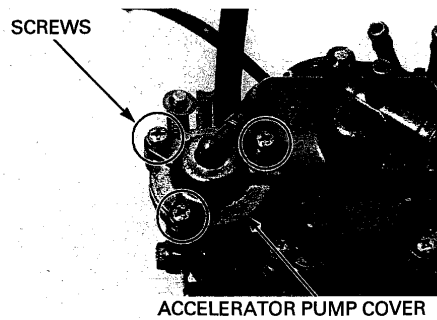

Remove the accelerator pump cover, spring and diaphragm/rod from the carburetor body.

Check the diaphragm for pin holes, deterioration or other damage.

Check the rod for wear or damage at the tip.

Check the orifice in the accelerator pump cover and carburetor body for clog or restriction.

Air will leak out of the vacuum chamber if the diaphragm is damaged in any way, even with just a pin hole.

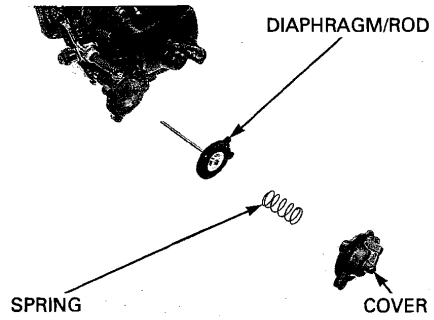

Check the pump rod boot for deterioration or damage.

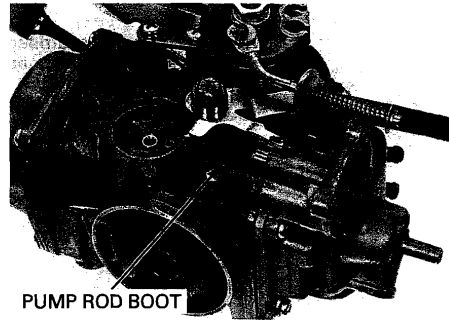

CARBURETOR HEATER

Remove the screws and set plate.

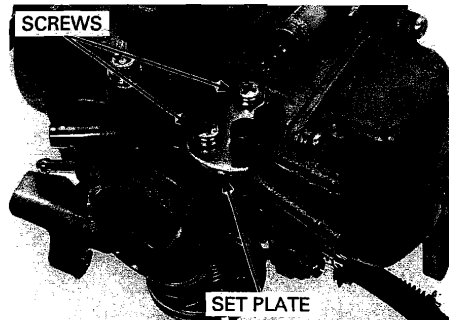

Remove the carburetor heater from the carburetor body.

Remove the O-rings from the carburetor heater.

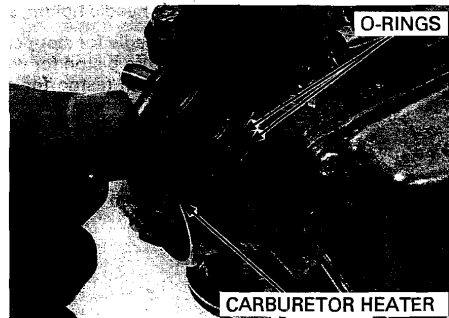

VACUUM CHAMBER

Remove the screws while holding the vacuum chamber cover.

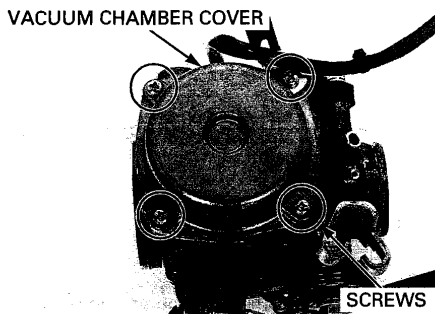

Remove the vacuum chamber cover, compression spring and diaphragm/vacuum piston from the carburetor body.

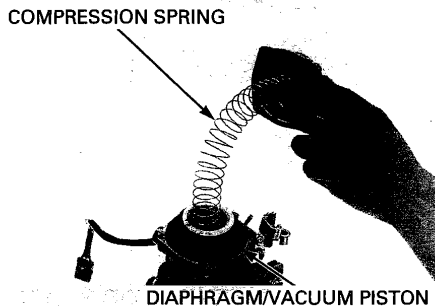

Be careful not to damage the diaphragm. Turn the jet needle holder counterclockwise using a screwdriver while pressing it in and release the holder flange from the vacuum piston.

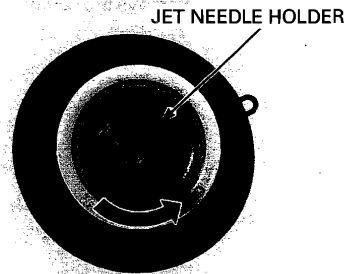

Remove the jet needle holder, spring and jet needle. Check the jet needle for stepped wear. Check the vacuum piston for wear or damage. Check the vacuum piston for smooth operation up and down in the carburetor body. Check the diaphragm for pin holes, deterioration or other damage. Air will leak out of the vacuum chamber if the diaphragm is damaged in any way, even with just a pin hole.

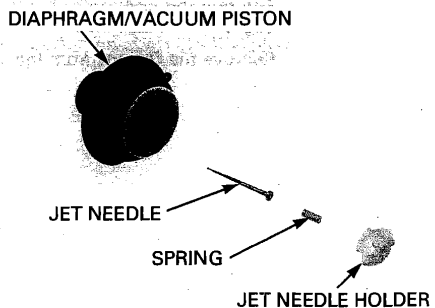

JETS AND FLOAT

Remove the following:

- Accelerator pump link mounting bolt
- Plastic washer
- Collar
- Plain washers
- Spring washer
- Cotter pin
- Accelerator pump link

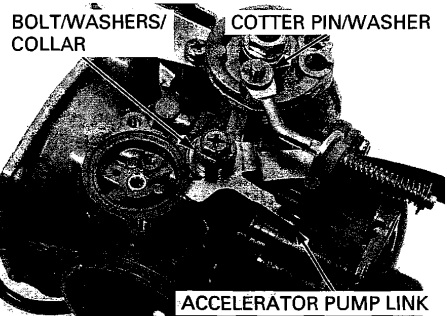

Remove the screws, float chamber and O-ring.

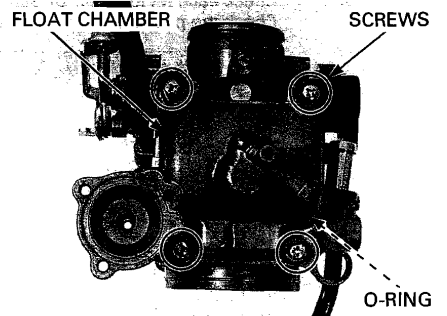

Remove the float pin, float and float valve.
Check the float for damage or fuel in the float.

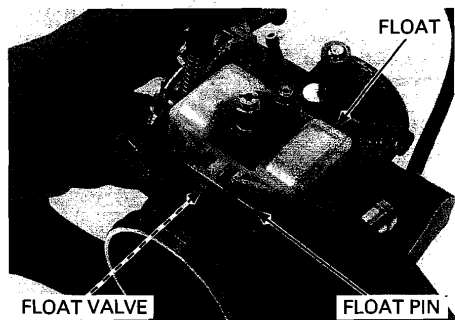

Check the float valve and valve seat for scoring, scratches, clogs or damage.
Check the tip of the float valve where it contacts the valve seat, for stepped wear or contamination.
Check the operation of the float valve.

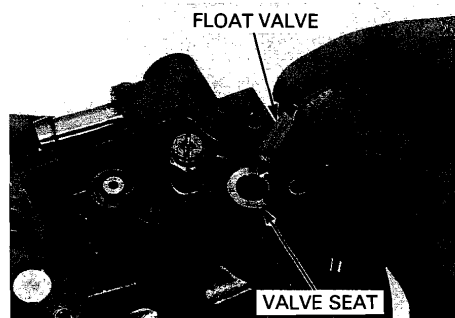

FUEL SYSTEM

Handle all jets with care. They can easily be scored or scratched.

Damage to the pilot screw seat will occur if the pilot screw is tightened against the seat.

Remove the following:

- Main jet
- Needle jet holder
- Needle jet
- Slow jet

Turn the pilot screw in and carefully count the number of turns until it seats lightly. Make a note of this to use as a reference when reinstalling the pilot screw.

TOOL:

Pilot screw wrench

07KMA-MS60102 or
07MMA-MT3010B
(U.S.A. only)

Remove the pilot screw, spring, washer and O-ring.

Check each jet for wear or damage.
Check the pilot screw for wear or damage.

Clean the jets with cleaning solvent.

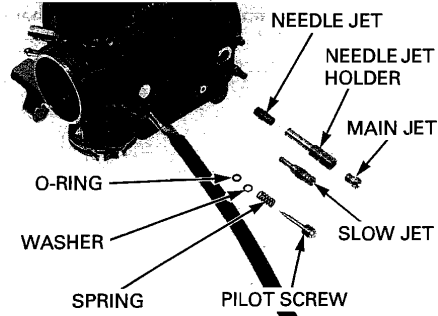
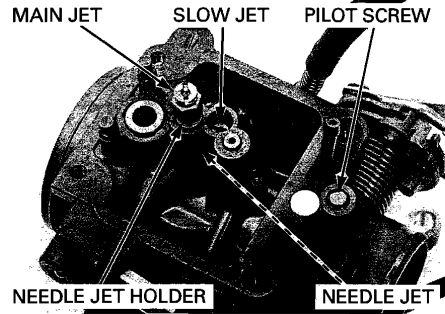

CARBURETOR CLEANING

Cleaning the air and fuel passages with a piece of wire will damage the carburetor body.

Blow open all air and fuel passages in the carburetor body and float chamber with compressed air.

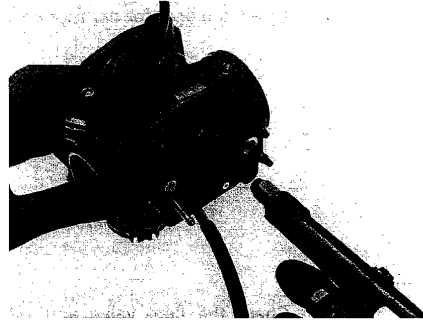

CARBURETOR ASSEMBLY

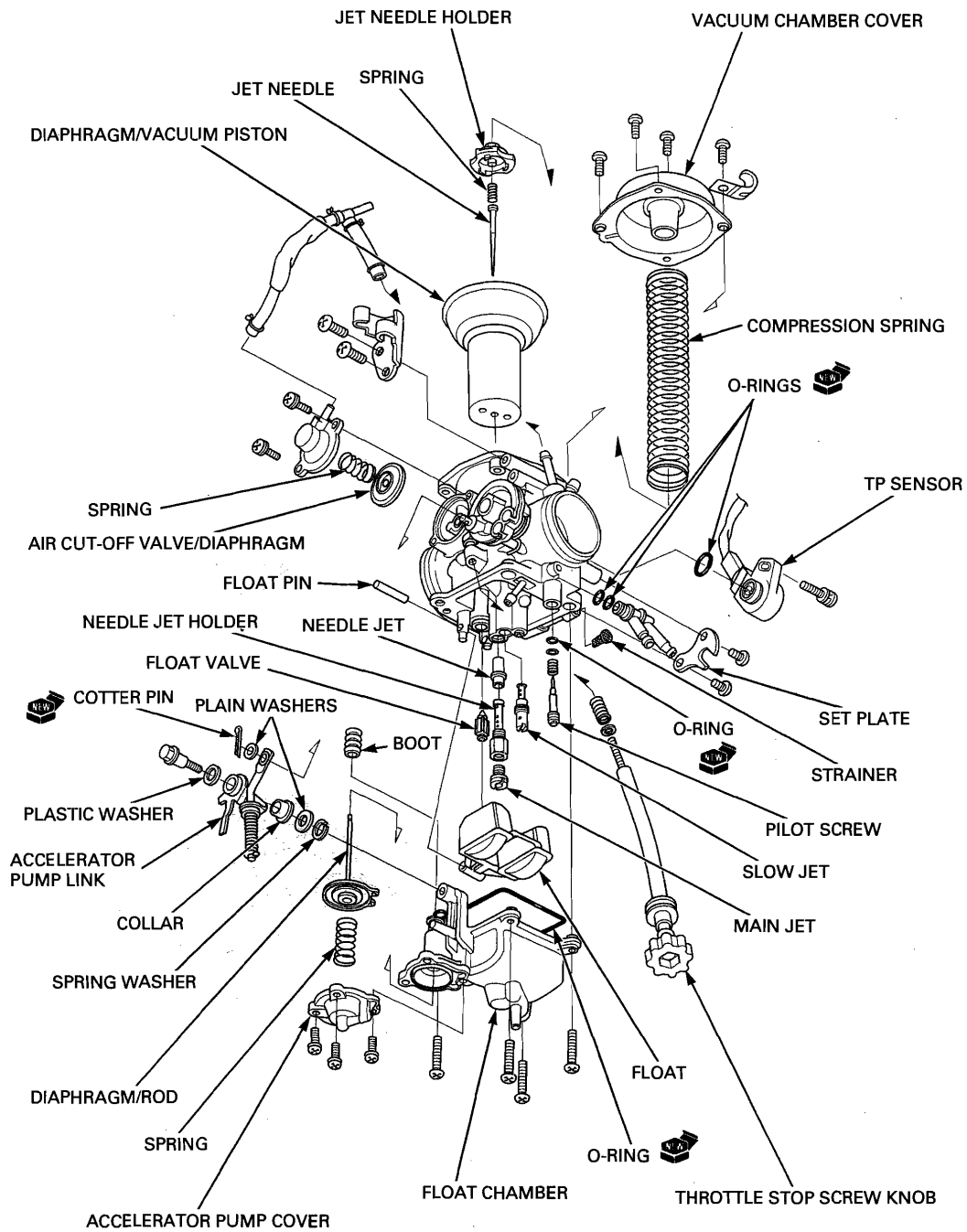

JETS AND FLOAT

Damage to the pilot screw seat will occur if the pilot screw is tightened against the seat.

Install the pilot screw with the spring, washer and a new O-ring until it seats lightly. Return it to its original position as noted during removal.

TOOL:

Pilot screw wrench

**07KMA-MS60102or
07MMA-MT3010B
(U.S.A. only)**

Perform the pilot screw adjustment if a new pilot screw is installed (page 6-25).

Handle all jets with care. They can easily be scored or scratched.

Install the needle jet, needle jet holder, main jet and slow jet.

TORQUE:

Needle jet holder: 2.3 N·m (0.2 kgf·m, 1.7 lbf·ft)

Main jet: 2.1 N·m (0.2 kgf·m, 1.5 lbf·ft)

Slow jet: 1.8 N·m (0.2 kgf·m, 1.3 lbf·ft)

Hang the float valve onto the float arm lip. Install the float with the float valve and insert the float pin.

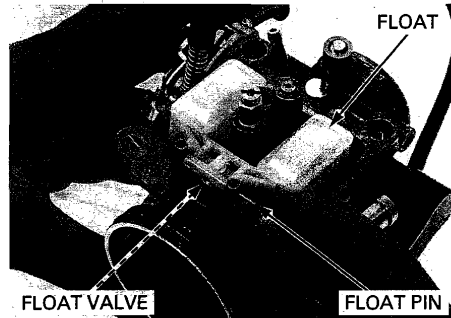
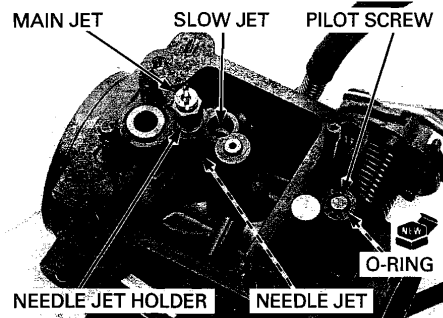

FLOAT LEVEL INSPECTION

NOTE:

Check the float level after checking the float valve, valve seat and float.

Set the float level gauge so it is perpendicular to the float chamber face at the highest point of the float.

With the float valve seated and the float arm just touching the valve, measure the float level with the float level gauge.

TOOL:

Carburetor float level gauge 07401-0010000

Float level: 18.5 mm (0.73 in)

The float cannot be adjusted. Replace the float if the float level is out of specification.

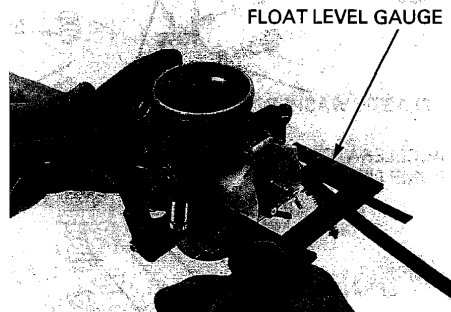

Install a new O-ring into the float chamber groove properly.

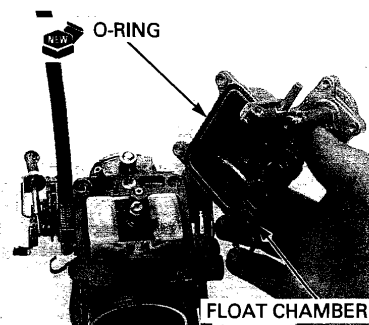

Install the float chamber and tighten the float chamber screws to the specified torque.

TORQUE: 2.1 N-m (0.2 kgf-m, 1.5 lbf-ft)

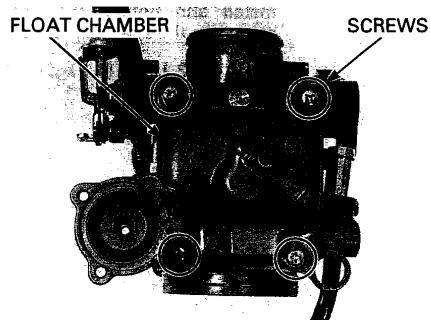

Install the following:

- Spring washer
- Plain washers
- Collar
- Accelerator pump link
- Plastic washer
- New cotter pin

Tighten the accelerator pump link mounting bolt to the specified torque.

TORQUE: 3.4 N-m (0.3 kgf-m, 2.5 lbf-ft)

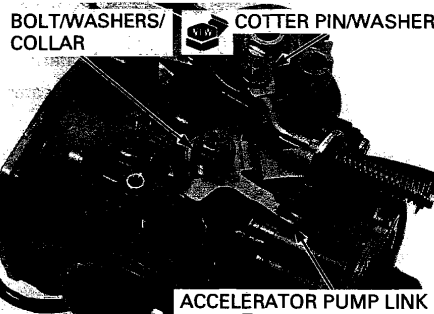

VACUUM CHAMBER

Insert the jet needle into the vacuum piston.

Install the spring into the jet needle holder and set the jet needle holder into the vacuum piston.

Turn the jet needle holder clockwise while pressing it until it locks.

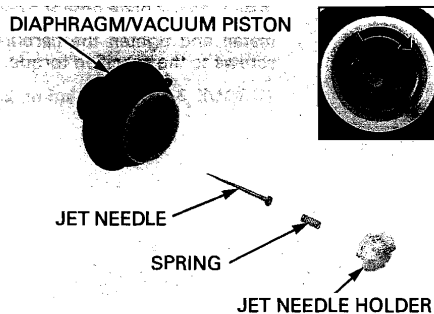

FUEL SYSTEM

Install the diaphragm/vacuum piston into the carburetor body being careful not to damage the jet needle.

Lift the bottom of the piston with your finger to set the diaphragm rib into the groove in the carburetor body.

Be careful not to pinch the diaphragm.

Install the compression spring and vacuum chamber cover while lifting the piston in place. Align the bosses of the cover with the grooves of the carburetor body and secure the cover with at least two screws before releasing the vacuum piston.

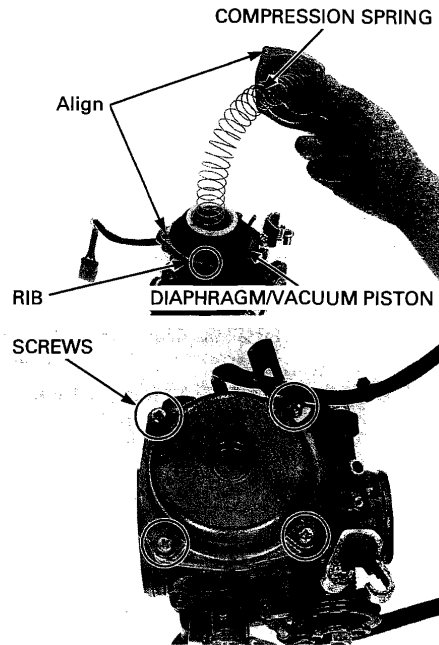

Install and tighten the vacuum chamber cover screws to the specified torque.

TORQUE: 2.1 N-m (0.2 kgf-m, 1.5 lbf-ft)

CARBURETOR HEATER

Coat new O-rings with engine oil and install them onto the carburetor heater.

Install the carburetor heater into the carburetor body.

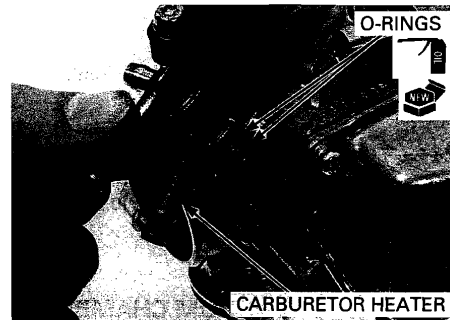

Install the set plate onto the carburetor heater.

Install and tighten the carburetor heater set plate screws to the specified torque.

TORQUE: 3.4 N-m (0.3 kgf-m, 2.5 lbf-ft)

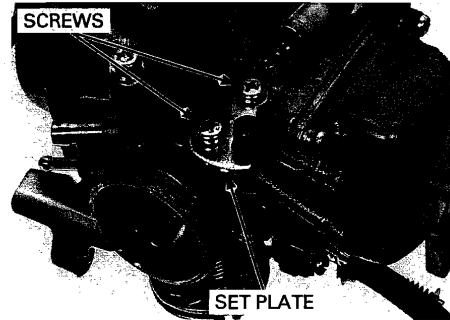

ACCELERATOR PUMP

Be careful not to pinch the diaphragm.

Install the diaphragm/rod, spring and cover to the float chamber cover.

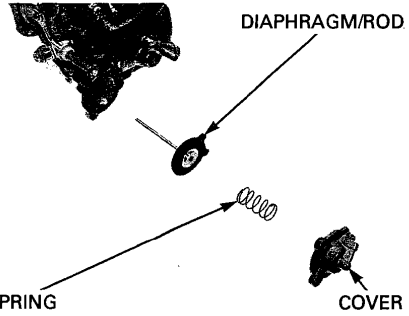

Install and tighten the accelerator pump cover screws to the specified torque while holding the cover.

TORQUE: 2.1 N·m (0.2 kgf·m, 1.5 lbf·ft)

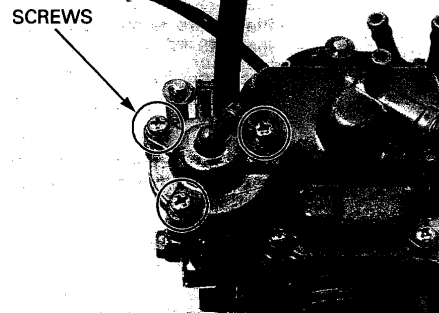

AIR CUT-OFF VALVE

Be careful not to pinch the diaphragm.

Install the air cut-off valve/diaphragm, spring and cover onto the carburetor body.

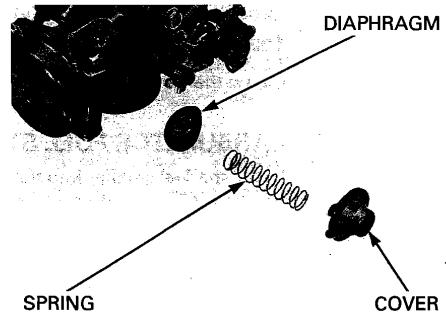

Install the air cut-off valve cover screws while holding the air cut-off valve cover, and tighten it to the specified torque.

TORQUE: 2.1 N·m (0.2 kgf·m, 1.5 lbf·ft)

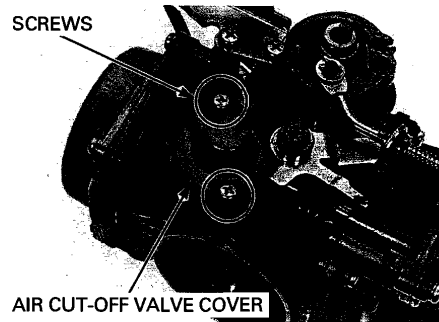

TP SENSOR

Apply engine oil to a new O-ring and install it to the TP sensor groove.

Install the TP sensor by aligning its slot with the flat of the throttle shaft.

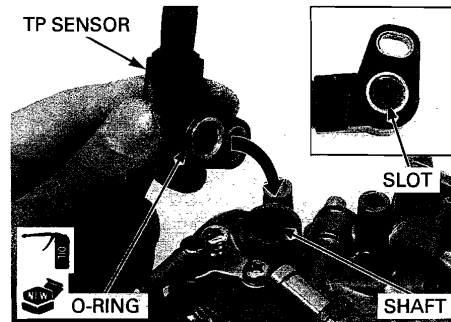

Measure the resistance (A) between the Blue and Black wire terminals at the TP sensor connector (page 19-10).

Resistance (A):

STANDARD: 4 – 6 k Ω (20°C/68°F)

Measure the resistance (B) between the Yellow and Black wire terminal, then adjust the TP sensor initial position so that the resistance (B) is within the standard value.

Resistance (B) = Resistance (A) x (0.09 to 0.11)

e.g:

When the resistance (A) is 5 k Ω , the resistance (B) should be 450 – 550 Ω .

Tighten the TP sensor torx screw to the specified torque at the initial position.

TORQUE: 3.4 N·m (0.3 kgf·m, 2.5 lbf·ft)

Clamp the TP sensor wire.

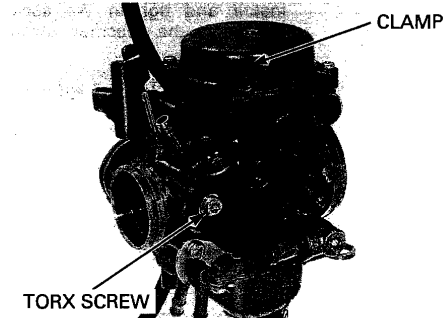

CARBURETOR FUEL STRAINER

Install the fuel strainer into the carburetor body.



SE VALVE

Install the SE valve and tighten the SE valve nut to the specified torque.

TORQUE: 2.3 N-m (0.2 kgf-m, 1.7 lbf-ft)

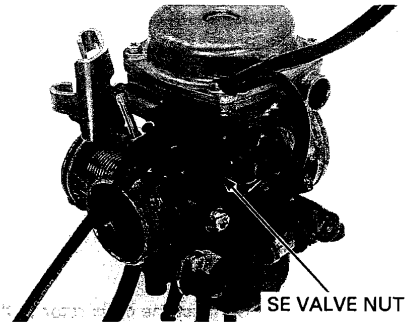

Connect the fuel and PAIR control valve vacuum hoses.

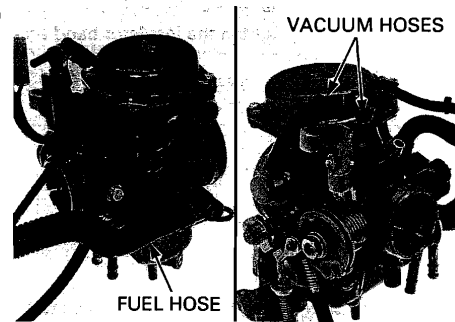

CARBURETOR INSTALLATION

Connect the water hoses to the carburetor heater and release the clamps.

California type only: Connect the EVAP purge control valve vacuum hose to the carburetor.

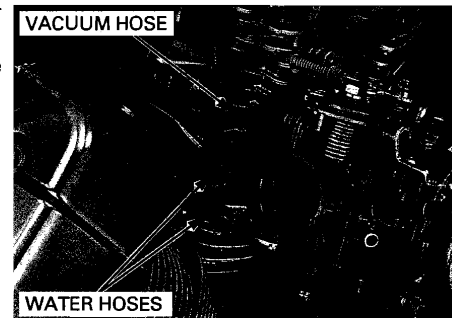

Connect the carburetor air vent (California type: fuel cut-off solenoid valve) hose to the carburetor.

California type only: Connect the EVAP purge control valve hose (to throttle bore).

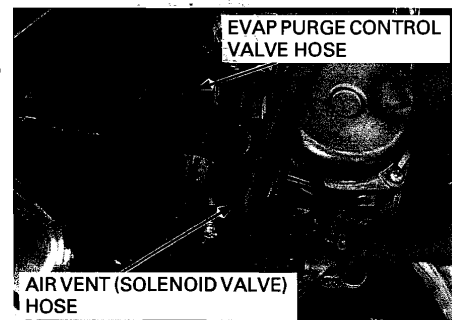

FUEL SYSTEM

Connect the throttle cables to the throttle drum and install them onto the cable stays.

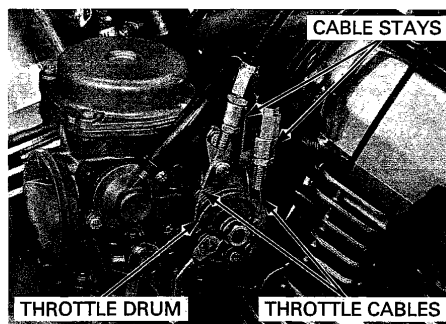

Connect the carburetor to the insulator while aligning its lug with the insulator groove.

Tighten the insulator band screw securely.

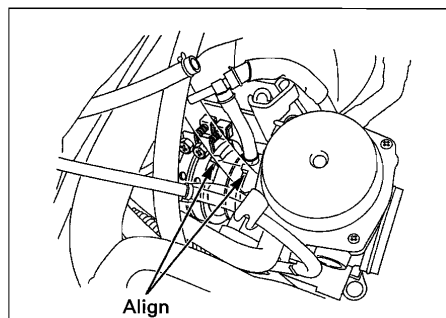

Except california type: Connect the air vent hose to the clamp.

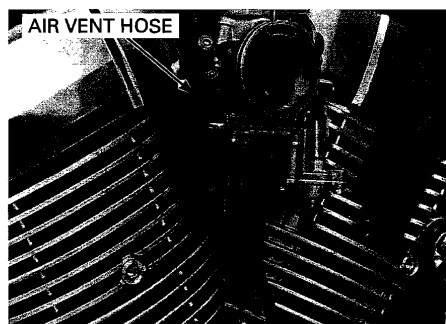

Connect the TP sensor 3P connector.
Connect the PAIR control valve vacuum hose to the 3-way joint.

Install the following:

- Air cleaner housing (page 6-7)
- Fuel tank (page 3-4)

Perform the following inspections and adjustments:

- Engine idle speed (page 4-15)
- Throttle operation (page 4-5)
- Pilot screw if it was replaced (page 6-25)

California type shown:

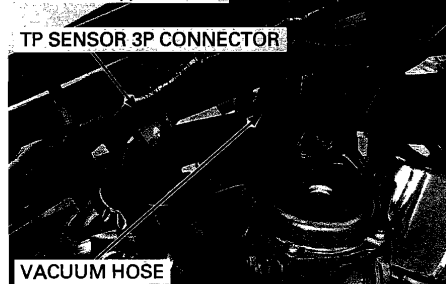

INTAKE MANIFOLD

REMOVAL

Drain the coolant from the cooling system (page 7-6).

Remove the carburetor (page 6-7).

Loosen the insulator band screw and remove the insulator from the intake manifold.

Disconnect the water hose from the rear cylinder head.

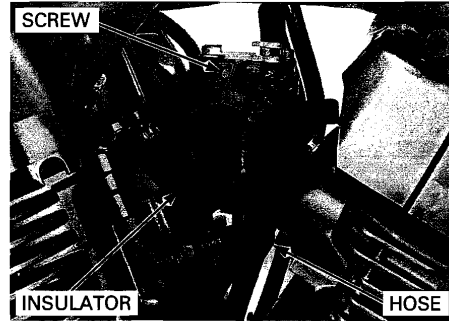

Remove the bolts and choke cable stay.

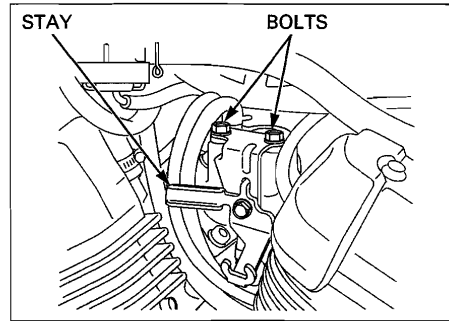

Remove the bolts, intake manifold and O-rings.

Seal the intake ports of the cylinder heads with tape or clean cloths to keep dirt and debris from entering the engine.

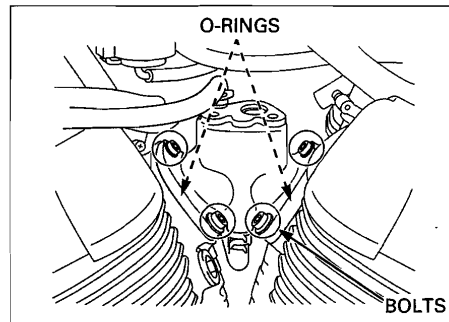

INSTALLATION

Install new O-rings onto the intake manifold.

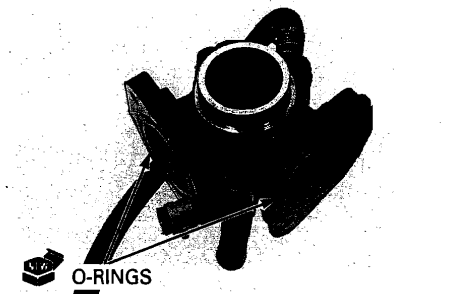

FUEL SYSTEM

Install the intake manifold onto the cylinder heads.
Install the bolts and tighten them.

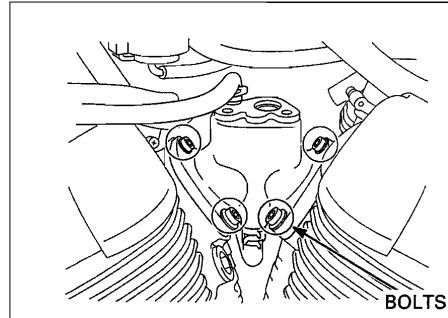

Install the choke cable stay and bolts.
Tighten the bolts securely.

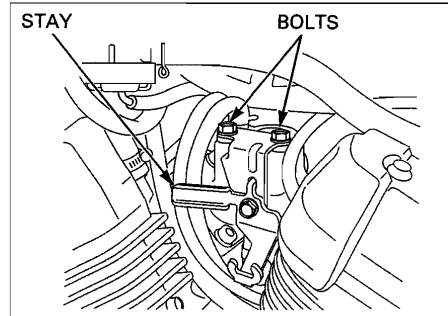

Install the insulator with the "CARB" mark facing the carburetor side, aligning its groove with the lug on the manifold.
Tighten the insulator band screw securely.
Install the carburetor (page 6-21).
Fill and bleed the cooling system (page 7-7).

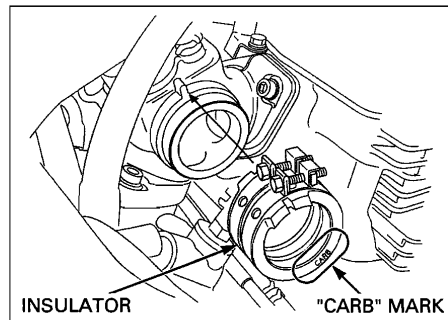

PILOT SCREW ADJUSTMENT

IDLE DROP PROCEDURE

NOTE:

- The pilot screw is factory pre-set and no adjustment is necessary unless the pilot screw is replaced.
- Use a tachometer with graduations of 50 rpm or smaller that will accurately indicate 50 rpm change.

Damage to the pilot screw seat will occur if the pilot screw is tightened against the seat.

1. Turn the pilot screw clockwise until it seats lightly, then back it out to specification given. This is an initial setting prior to the final pilot screw adjustment.

TOOL:

Pilot screw wrench	07KMA-MS60102
Pilot screw elbow guide	07PMA-MZ20110
or	
Pilot screw wrench	07MMA-MT3010B
	(U.S.A. only)
Pilot screw elbow guide	07PMA-MZ2011A
	(U.S.A. only)

INITIAL OPENING:

49 states/Canada type: 2 turns out
California type: 2-1/8 turns out

2. Warm up the engine to operating temperature. Ride the motorcycle for approximately 10 minutes.
3. Stop the engine and connect a tachometer according to its manufacturer's instructions.
4. Remove the fuel tank (page 3-4) and disconnect the PAIR control valve vacuum hose and plug it to keep air from entering, then connect a vacuum pump to the PAIR control valve vacuum hose joint.
5. Apply more than specified vacuum (page 6-28) to the PAIR control valve vacuum hose and install the fuel tank (page 3-4).

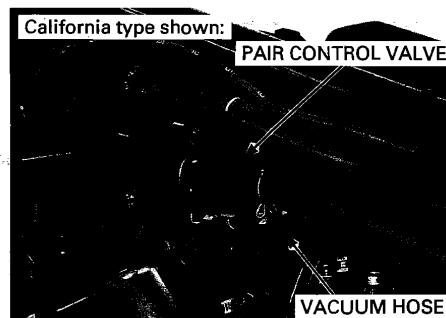
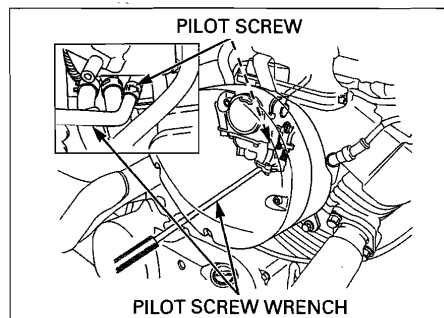

6. Start the engine and adjust the idle speed with the throttle stop screw knob.
TEMPORARY IDLE SPEED: 1,200 ± 100 rpm
7. Turn the pilot screw in or out slowly to obtain the highest engine speed.
8. Lightly open the throttle 2 or 3 times, then adjust the idle speed with the throttle stop screw knob.
9. Turn the pilot screw in gradually until the engine speed drops by 50 rpm.
10. Turn the pilot screw out the final opening from the position obtained in step 9.

FINAL OPENING: 1/4 turns out

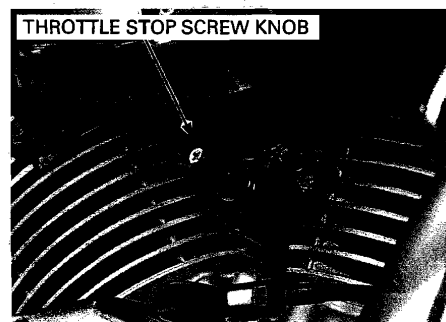

FUEL SYSTEM

11. Remove the fuel tank (page 3-4).

Remove the plug from the vacuum hose, then disconnect the vacuum pump and connect the vacuum hose to the PAIR control valve vacuum hose joint. Install the fuel tank (page 3-4).

12. Readjust the idle speed with the throttle stop screw knob.

IDLE SPEED: 1,200 ± 100 rpm

13. Disconnect the tachometer.

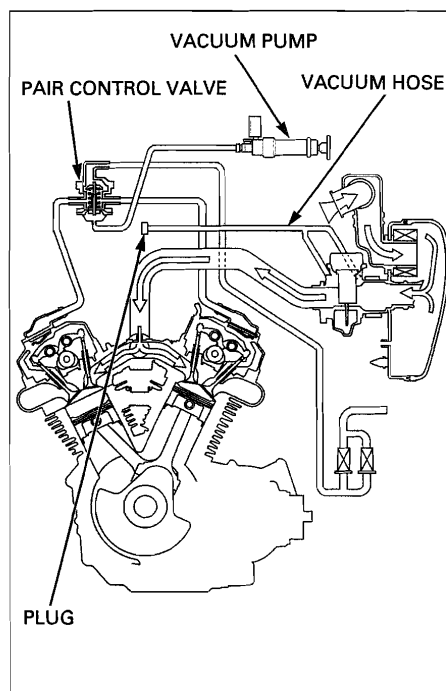

HIGH ALTITUDE ADJUSTMENT

This adjustment must be made at high altitude to ensure proper high altitude operation.

When the vehicle is to be operated continuously above 6,500 feet (2,000 m), the carburetor setting must be changed as described below to improve driveability and decrease exhaust emissions.

		STANDARD SETTING	HIGH ALTITUDE SETTING
		Below 5,000 ft (1,500 m)	Above 6,500 ft (2,000 m)
Main jet		#122	#120
Pilot screw opening	49 states/Canada type	Factory preset (2 turns out)	3/4 turn in from factory preset (1-1/4 turns out)
	California type	Factory preset (2-1/8 turns out)	3/4 turn in from factory preset (1-3/8 turns out)
PAIR control valve*		P/N: 18650-MFE-671	P/N: 18650-MFE-801

* If afterburn appears when snapping the throttle grip closed, during engine braking, it is necessary to replace the PAIR control valve (page 6-29) for high altitude riding in addition to changing the carburetor setting.

Remove the carburetor (page 6-7) and the float chamber.

Replace the standard main jet with the high altitude type.

HIGH ALTITUDE MAIN JET: #120

Check that the O-ring on the float chamber is in good condition, replace it if necessary.

Install the float chamber and carburetor (page 6-21).

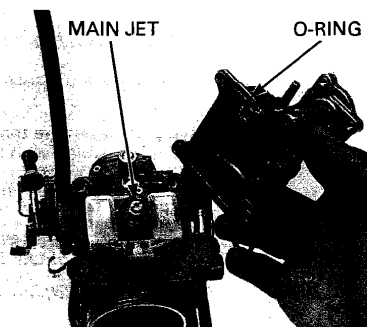

Warm up the engine to operating temperature. Ride the motorcycle for approximately 10 minutes.

Turn the pilot screw in to the specification given.

TOOL:

- Pilot screw wrench** 07KMA-MS60102
- Pilot screw elbow guide** 07PMA-MZ20110
- or
- Pilot screw wrench** 07MMA-MT3010B (U.S.A. only)
- Pilot screw elbow guide** 07PMA-MZ2011A (U.S.A. only)

HIGH ALTITUDE PILOT SCREW OPENING:
 3/4 turn in from the factory preset position

Adjust the idle speed with the throttle stop screw knob.

IDLE SPEED: 1,200 ± 100 rpm

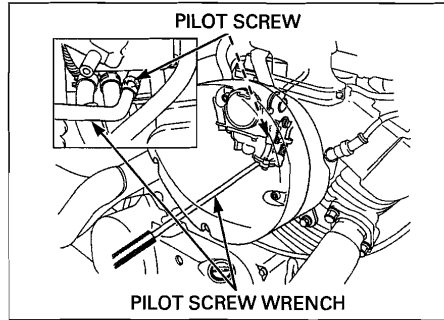

Do not attach the label to any part that can be easily removed from the vehicle.

Attach the Vehicle Emission Control Information Update label on the rear fender near the frame cross pipe as shown. See Service Letter No. 132 for information on obtaining the label.

NOTICE

Sustained operation at an altitude lower than 5,000 feet (1,500 m) with the parts replaced and adjusted for high altitude settings may cause the engine to idle roughly and stall in traffic. It may also cause engine damage due to overheating.

This adjustment must be made at low altitude to ensure proper low altitude operation.

When the vehicle is to be operated continuously below 5,000 feet (1,500 m), replace and readjust the parts as follows:

Replace main jet with the standard main jet, and screw out the pilot screw to the specified number of turns from the high altitude setting.

STANDARD MAIN JET: #122

LOW ALTITUDE PILOT SCREW OPENING:
 3/4 turn out from the high altitude setting

Replace the PAIR control valve with the standard type.

Warm up the engine and adjust the idle speed at low altitude with the throttle stop screw.

UPDATE LABEL:

VEHICLE EMISSION CONTROL INFORMATION UPDATE
 -HONDA MOTOR CO., LTD.

THIS VEHICLE HAS BEEN ADJUSTED TO IMPROVE EMISSION CONTROL PERFORMANCE WHEN OPERATED AT HIGH ALTITUDE.

ALTITUDE PERFORMANCE ADJUSTMENT INSTRUCTIONS ARE AVAILABLE AT YOUR AUTHORIZED HONDA DEALER.

SECONDARY AIR SUPPLY SYSTEM

SYSTEM INSPECTION

Warm up the engine to operating temperature.

Remove the fuel tank (page 3-4).

Check that the secondary air supply hoses are clean and free of carbon deposits.

Check the PAIR check valves if the hoses are carbon fouled (page 6-29).

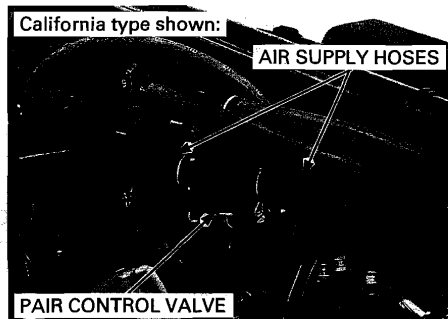

Disconnect the PAIR control valve vacuum hose and plug the vacuum hose.

Connect a vacuum pump to the PAIR control valve.

Install the fuel tank (page 3-4).

Start the engine and open the throttle slightly to be certain that air is sucked in through the air suction hose.

If the air is not drawn in, check the air suction hoses for clogs.

With the engine running, gradually apply vacuum to the PAIR control valve vacuum hose.

Check that the air suction hose stops drawing air, and that the vacuum does not bleed.

SPECIFIED VACUUM:

STANDARD SETTING: 65 kPa (485 mmHg)

HIGH ALTITUDE SETTING: 57 kPa (425 mmHg)

If the air is drawn in, or if the specified vacuum is not maintained, install a new PAIR control valve.

If afterburn occurs on deceleration, even when the secondary air supply system is normal, check the air cut-off valve.

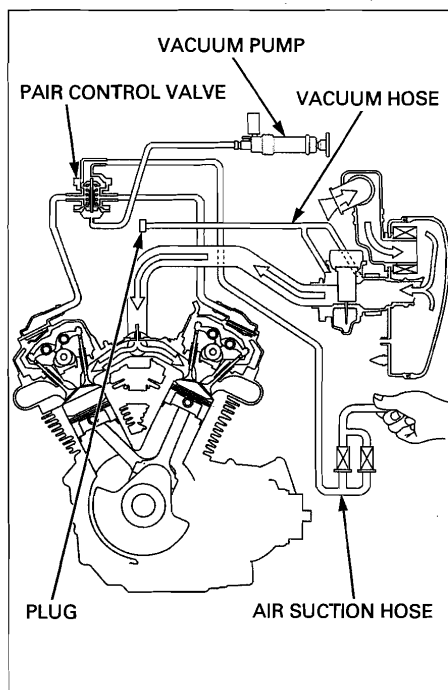

PAIR CONTROL VALVE REMOVAL/INSTALLATION

Remove the fuel tank (page 3-4).
 Disconnect the vacuum, air supply, and air suction hoses.
 Remove the PAIR control valve.

Route the hoses properly (page 1-22).

Installation is in the reverse order of removal.

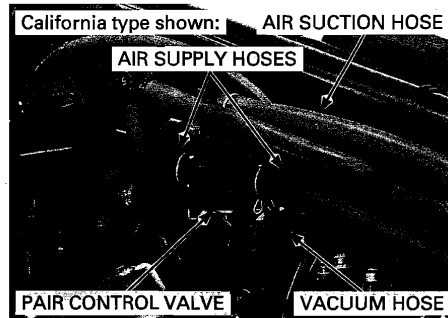

PAIR CHECK VALVE INSPECTION

Remove the fuel tank (page 3-4).
 Remove the bolts and PAIR check valve cover.

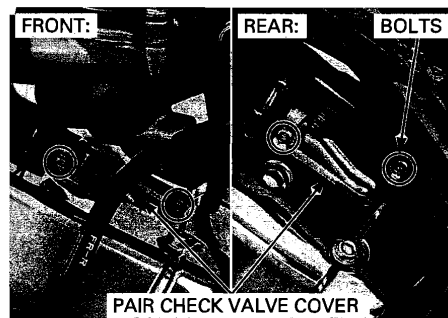

Remove the PAIR check valve from the cylinder head cover.

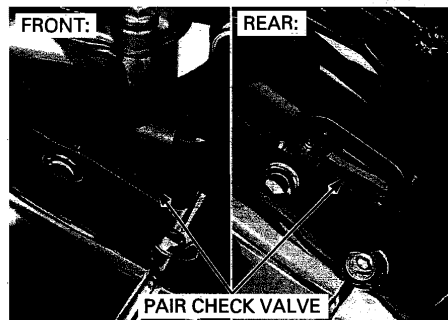

Check the reed for damage or fatigue. Replace if necessary.

Replace the PAIR check valve if the rubber seat is cracked, deteriorated or damaged, or if there is clearance between the reed and seat.

Install the PAIR check valve in the reverse order of removal.

TORQUE: 7 N·m (0.7 kgf·m, 5.2 lbf·ft)

Install the fuel tank (page 3-4).

REED STOPPER



REED



RUBBER SEAT

EVAP CONTROL SYSTEM (California type only)

EVAP CANISTER REMOVAL/INSTALLATION

Disconnect the following hoses from the EVAP canister:

- EVAP canister hose
- EVAP canister hose (to fuel tank)
- EVAP canister air vent hose
- EVAP canister drain hose

Remove the bolt, collar and EVAP canister from the bracket.

Route the hoses properly (page 1-35).

Install the EVAP canister in the reverse order of removal.

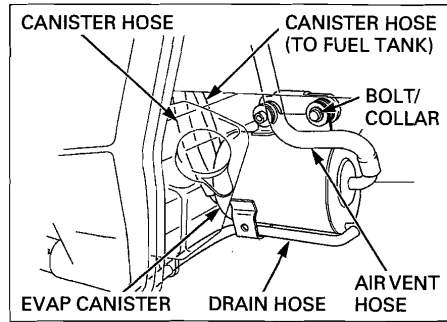

EVAP PURGE CONTROL VALVE

REMOVAL/INSTALLATION

Remove the fuel tank (page 3-4).

Disconnect the EVAP purge control valve hoses and EVAP purge control valve vacuum hose (page 1-35).

Remove the EVAP purge control valve.

Route the hoses properly (page 1-35).

Installation is in the reverse order of removal.



INSPECTION

NOTE:

The EVAP purge control valve should be inspected if hot restart is difficult.

Remove the EVAP purge control valve (page 6-30).

Connect a vacuum pump to the throttle bore port. Apply the specified vacuum to the EVAP purge control valve.

SPECIFIED VACUUM: 50 mm Hg (2.0 in Hg)

The specified vacuum should be maintained. Replace the EVAP purge control valve if vacuum is not maintained.

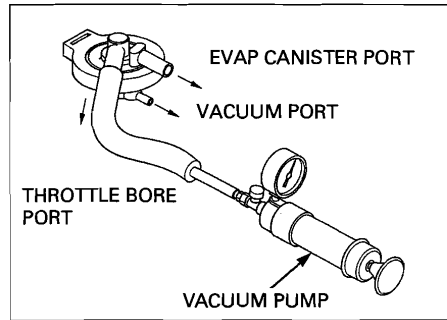

Remove the vacuum pump and connect it to the vacuum port.
Apply the specified vacuum to the EVAP purge control valve.

SPECIFIED VACUUM: 250 mm Hg (9.8 in Hg)

The specified vacuum should be maintained.
Replace the EVAP purge control valve if vacuum is not maintained.

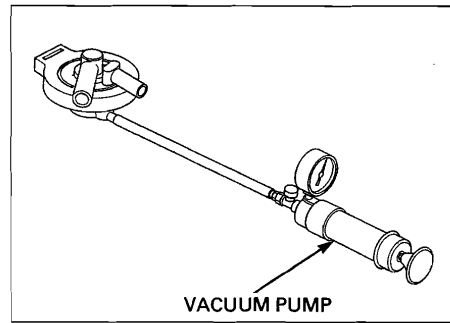

Damage to the EVAP purge control valve may result from use of a high pressure air source. Use a hand-operated air pump only.

Connect a pressure pump to the EVAP canister port.

While applying the specified vacuum to the vacuum port, pump air through the EVAP canister port.

SPECIFIED VACUUM: 25 mm Hg (1.0 in Hg)

Air should flow through the EVAP purge control valve and out the throttle bore port.
Replace the EVAP purge control valve if air does not flow out.

Remove the pumps and install the EVAP purge control valve (page 6-30).

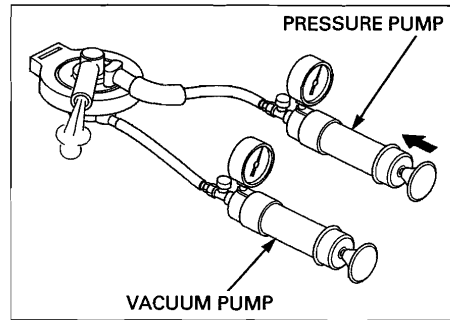

EVAP CAV CONTROL VALVE

REMOVAL/INSTALLATION

Remove the fuel tank (page 3-4).

Disconnect the EVAP CAV control valve hoses and vacuum hose (page 1-35).

Remove the EVAP CAV control valve from the stay.



INSPECTION

NOTE:

The EVAP CAV control valve should be inspected if hot restart is difficult.

Remove the EVAP CAV control valve (page 6-31).

Connect a vacuum pump to the vacuum port. Apply the specified vacuum to the EVAP CAV control valve.

SPECIFIED VACUUM: 500 mm Hg (19.7 in Hg)

The specified vacuum should be maintained. Replace the EVAP CAV control valve if vacuum is not maintained.

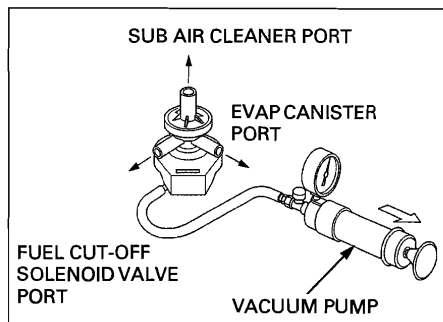

Remove the vacuum pump and connect it to the sub air cleaner port. Apply vacuum to the EVAP CAV control valve. The vacuum should hold steady. Replace the EVAP CAV control valve if vacuum leaks.

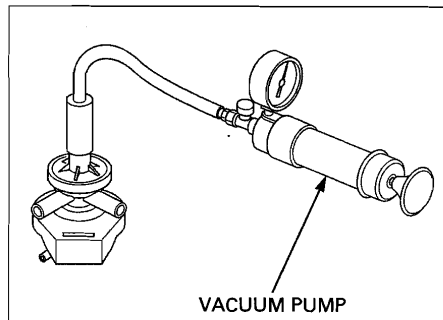

Remove the vacuum pump and reconnect it to the vacuum port. Connect a pressure pump to the sub air cleaner port.

Damage to the EVAP CAV control valve may result from use of a high pressure air source. Use a hand-operated air pump only.

While applying vacuum to the vacuum port, pump air through the sub air cleaner port. Air should flow through the EVAP CAV control valve and out the fuel cut-off solenoid valve port.

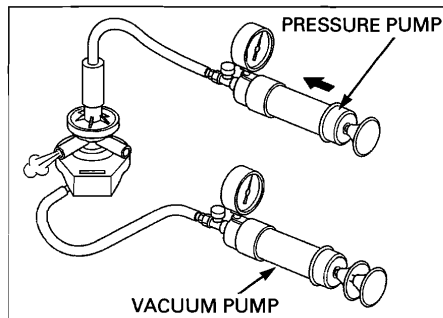

Plug the fuel cut-off solenoid valve port. While applying vacuum to the vacuum port, pump air through the sub air cleaner port. It should hold steady.

Replace the EVAP CAV control valve if pressure is not retained.

Remove the pumps and install the EVAP CAV control valve (page 6-31).

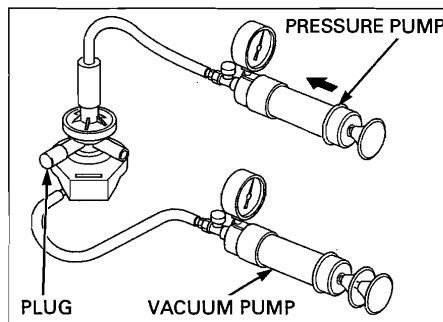

FUEL CUT-OFF SOLENOID VALVE

REMOVAL/INSTALLATION

Remove the following:

- Steering side covers (page 3-5)
- Fuel tank (page 3-4)

Release the wire band and disconnect the fuel cut-off solenoid valve 2P connector.

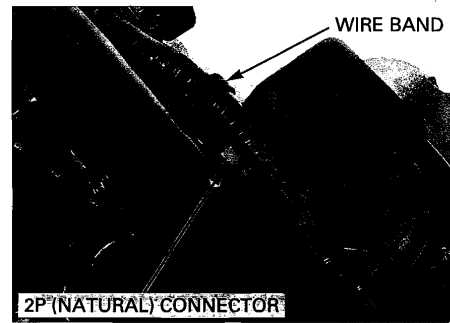

Disconnect the fuel cut-off solenoid valve hose, EVAP CAV control valve hose and vacuum hose (page 1-35).

Remove the fuel cut-off solenoid valve from the stay.

Route the solenoid valve hoses and wire properly (page 1-35).

Installation is in the reverse order of removal.



INSPECTION

Remove the fuel cut-off solenoid valve (page 6-33).

Damage to the fuel cut-off solenoid valve may result from use of a high pressure air source. Use a hand-operated air pump only.

Connect a vacuum pump to the vacuum port. Apply the specified vacuum to the fuel cut-off solenoid valve.

TOOL:
Vacuum pump **Commercially available**

SPECIFIED VACUUM: 250 mm Hg

The specified vacuum should be maintained.

Replace the fuel cut-off solenoid valve if vacuum is not maintained.

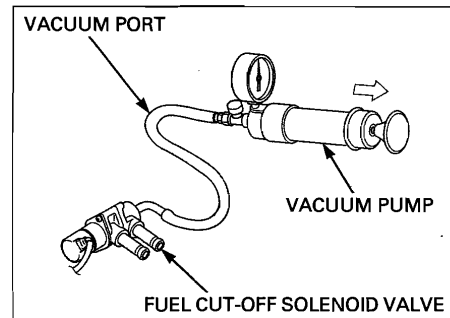

Remove the vacuum pump.

Connect the pressure pump to the float chamber port.

Pump air through the EVAP CAV control valve port.

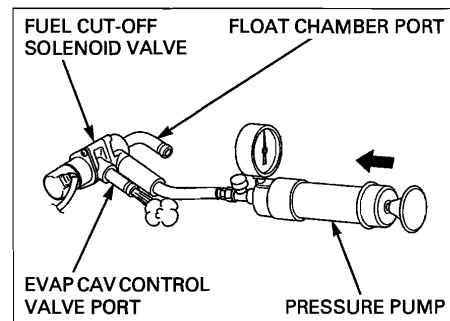

FUEL SYSTEM

Remove the pressure pump and connect it to the EVAP CAV control valve port.

Pump air through the float chamber port.

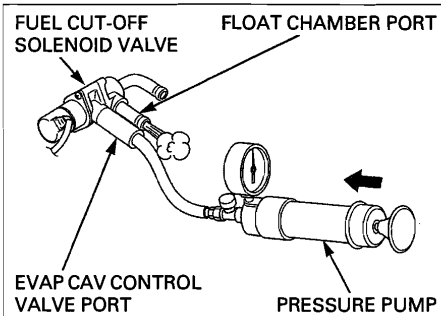

Connect the 12 V battery to the fuel cut-off solenoid valve 2P connector terminals.

Damage to the fuel cut-off solenoid valve may result from use of a high pressure air source.

Use a hand-operated air pump only.

Connect a vacuum pump to the EVAP CAV control valve port. Apply the specified vacuum to the fuel cut-off solenoid valve.

SPECIFIED VACUUM: 250 mm Hg

The specified vacuum should be maintained.

Replace the fuel cut-off solenoid valve if vacuum is not maintained.

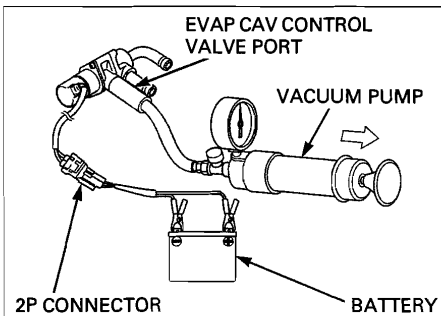

Remove the pressure pump and connect it to the vacuum port.

Pump air through the float chamber port.

Replace the fuel cut-off solenoid valve if necessary.

Remove the pressure pump and install the fuel cut-off solenoid valve in the reverse order of removal (page 6-33).

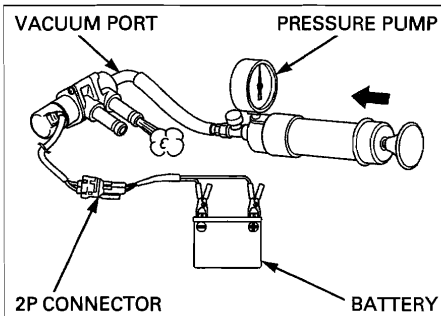

7. COOLING SYSTEM

SYSTEM FLOW PATTERN	7-2	THERMOSTAT	7-8
SERVICE INFORMATION	7-3	THERMOSTAT HOUSING	7-9
TROUBLESHOOTING	7-4	RADIATOR/COOLING FAN	7-11
SYSTEM TESTING	7-5	WATER PUMP	7-16
COOLANT REPLACEMENT	7-6	RADIATOR RESERVE TANK	7-17

COOLING SYSTEM
SYSTEM FLOW PATTERN

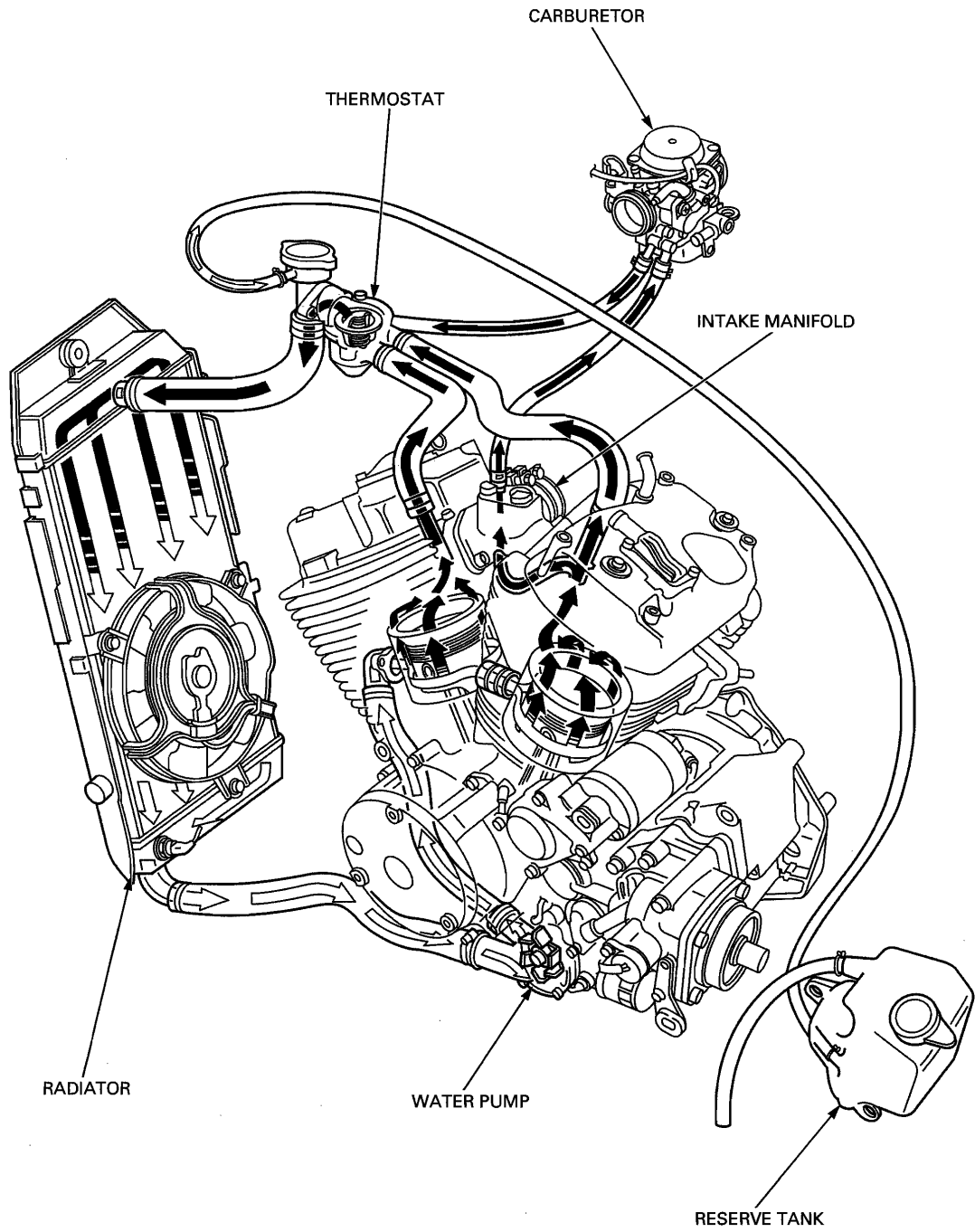

SERVICE INFORMATION**GENERAL****▲ WARNING**

Removing the radiator cap while the engine is hot can allow the coolant to spray out, seriously scalding you. Always let the engine and radiator cool down before removing the radiator cap.

NOTICE

Using coolant with silicate corrosion inhibitors may cause premature wear of water pump seals or blockage of radiator passages. Using tap water may cause engine damage.

- Add coolant at the reserve tank. Do not remove the radiator cap except to refill or drain the system.
- All cooling system service can be done with the engine in the frame.
- Avoid spilling coolant on painted surfaces.
- After servicing the system, check for leaks with a cooling system tester.
- For the ECT sensor switch (coolant temperature indicator) inspection (page 21-12).
- For fan motor switch inspection (page 21-14).

SPECIFICATIONS

ITEM		SPECIFICATIONS
Coolant capacity	Radiator and engine	1.58 liters (1.67 US qt, 1.39 Imp qt)
	Reserve tank	0.38 liter (0.40 US qt, 0.33 Imp qt)
Radiator cap relief pressure		108 – 137 kPa (1.1 – 1.4 kgf/cm ² , 16 – 20 psi)
Thermostat	Begin to open	80 – 84°C (176 – 183°F)
	Fully open	95°C (203°F)
	Valve lift	8 mm (0.3 in) minimum at 95°C (203°F)
Recommended antifreeze		Pro Honda HP Coolant or an equivalent high quality ethylene glycol antifreeze containing silicate-free corrosion inhibitors
Standard coolant concentration		1 : 1 (mixture with distilled water)

TORQUE VALUES

Radiator filler mounting bolt	10 N-m (1.0 kgf-m, 7 lbf-ft)	
Thermostat housing cover bolt	10 N-m (1.0 kgf-m, 7 lbf-ft)	
Fan motor mounting bolt	5.1 N-m (0.5 kgf-m, 3.8 lbf-ft)	
Cooling fan mounting nut	2.7 N-m (0.3 kgf-m, 2.0 lbf-ft)	Apply locking agent to the threads
Water pump cover bolt	13 N-m (1.3 kgf-m, 10 lbf-ft)	
Fan motor assembly mounting bolt	8.4 N-m (0.9 kgf-m, 6.2 lbf-ft)	
Water hose band screw	See page 7-10	

COOLING SYSTEM

TROUBLESHOOTING

Engine temperature too high

- Faulty coolant temperature indicator or ECT sensor switch
- Thermostat stuck closed
- Faulty radiator cap
- Insufficient coolant
- Passages blocked in radiator, hoses or water jacket
- Air in system
- Faulty fan motor
- Faulty fan motor switch
- Faulty water pump

Engine temperature too low

- Thermostat stuck open
- Faulty fan motor switch

Coolant leaks

- Faulty water pump mechanical seal
- Deteriorated O-rings
- Faulty radiator cap
- Damaged or deteriorated cylinder head gasket
- Loose hose connection or band
- Damaged or deteriorated hoses

SYSTEM TESTING

COOLANT (HYDROMETER TEST)

Remove the fuel tank (page 3-4).
Remove the radiator cap.

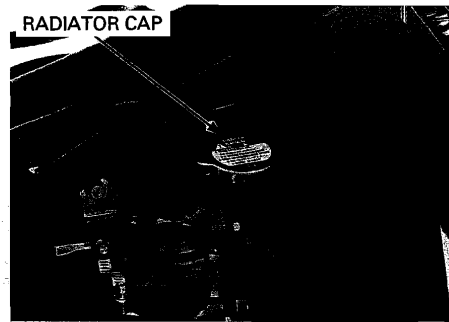

Test the coolant specific gravity using a hydrometer.

Look for contamination and replace the coolant if necessary.

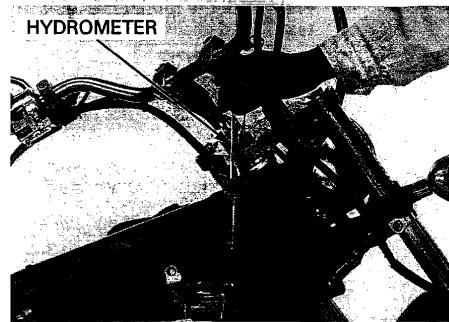

COOLANT GRAVITY CHART

		Coolant temperature °C (°F)										
		0 (32)	5 (41)	10 (50)	15 (59)	20 (68)	25 (77)	30 (86)	35 (95)	40 (104)	45 (113)	50 (122)
Coolant ratio %	5	1.009	1.009	1.008	1.008	1.007	1.006	1.005	1.003	1.001	0.999	0.997
	10	1.018	1.017	1.017	1.016	1.015	1.014	1.013	1.011	1.009	1.007	1.005
	15	1.028	1.027	1.026	1.025	1.024	1.022	1.020	1.018	1.016	1.014	1.012
	20	1.036	1.035	1.034	1.033	1.031	1.029	1.027	1.025	1.023	1.021	1.019
	25	1.045	1.044	1.043	1.042	1.040	1.038	1.036	1.034	1.031	1.028	1.025
	30	1.053	1.052	1.051	1.049	1.047	1.045	1.043	1.041	1.038	1.035	1.032
	35	1.063	1.062	1.060	1.058	1.056	1.054	1.052	1.049	1.046	1.043	1.040
	40	1.072	1.070	1.068	1.066	1.064	1.062	1.059	1.056	1.053	1.050	1.047
	45	1.080	1.078	1.076	1.074	1.072	1.069	1.066	1.063	1.060	1.057	1.054
	50	1.086	1.084	1.082	1.080	1.077	1.074	1.071	1.068	1.065	1.062	1.059
	55	1.095	1.093	1.091	1.088	1.085	1.082	1.079	1.076	1.073	1.070	1.067
60	1.100	1.098	1.095	1.092	1.089	1.086	1.083	1.080	1.077	1.074	1.071	

RADIATOR CAP/SYSTEM PRESSURE INSPECTION

Remove the radiator cap (page 7-5).

Wet the sealing surfaces of the cap, then install the cap onto the tester.

TOOLS:

Cooling system pressure tester SVTS4AH
Cooling system adaptor OTCJ33984A

Pressurize the radiator cap using the tester. Replace the radiator cap if it does not hold pressure, or if relief pressure is too high or too low. It must hold the specified pressure for at least 6 seconds.

RADIATOR CAP RELIEF PRESSURE:

108 – 137 kPa (1.1 – 1.4 kgf/cm², 16 – 20 psi)

Pressurize the radiator, engine and hoses using the tester, and check for leaks.

NOTICE

Excessive pressure can damage the cooling system components. Do not exceed 137 kPa (1.4 kgf/cm², 20 psi).

Repair or replace components if the system will not hold the specified pressure for at least 6 seconds.

Remove the tester and install the radiator cap.

Install the fuel tank (page 3-4).

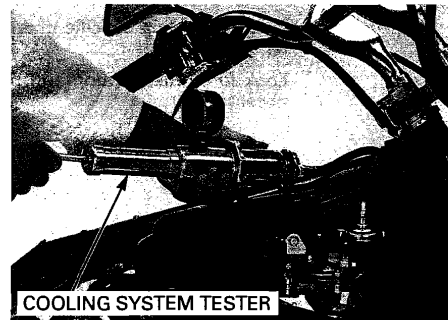
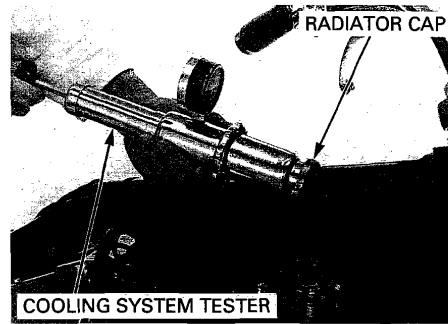

COOLANT REPLACEMENT

PREPARATION

NOTE:

- The effectiveness of coolant decreases with the accumulation of rust or if there is a change in the mixing proportion during usage. Therefore, for best performance change the coolant regularly as specified in the maintenance schedule.
- Mix only distilled, low mineral water with the recommended antifreeze.

RECOMMENDED ANTIFREEZE:

Pro Honda HP Coolant or an equivalent high quality ethylene glycol antifreeze containing silicate-free corrosion inhibitors

STANDARD COOLANT CONCENTRATION:

1 : 1 (mixture with distilled water)

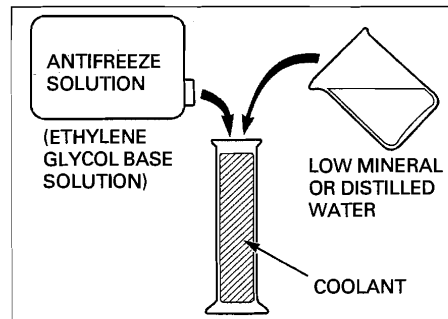

REPLACEMENT/AIR BLEEDING

NOTE:

When filling the system or reserve tank with coolant, or checking the coolant level, hold the motorcycle in an upright position.

Remove the fuel tank (page 3-4).

Remove the radiator cap.

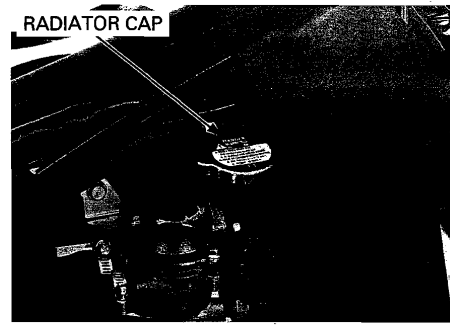

Drain the coolant from the system by removing the drain bolt and sealing washer.

Reinstall the drain bolt with a new sealing washer and tighten it to the specified torque.

TORQUE: 13 N·m (1.3 kgf·m, 10 lbf·ft)

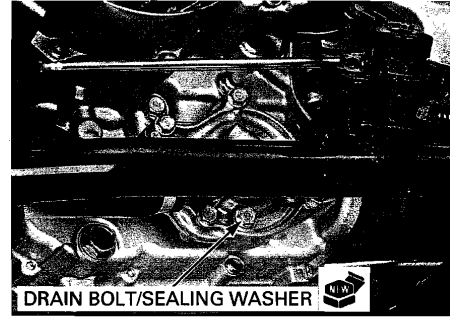

Remove the left crankcase rear cover (page 3-5).

Disconnect the siphon hose from the reserve tank and drain the coolant.

Empty the coolant by removing the reserve tank (page 7-17) and rinse the inside of the reserve tank with water.

Install the following:

- Reserve tank (page 7-17)
- Left crankcase rear cover (page 3-5)

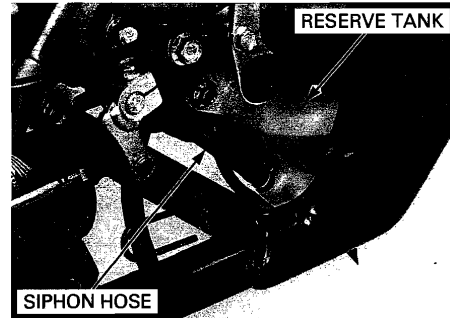

Fill the system with the recommended coolant through the filler opening up to the filler neck.

Install the fuel tank (page 3-4).

Bleed air from the system as follows:

1. Shift the transmission into neutral.
Start the engine and let it idle for 2 – 3 minutes.
2. Snap the throttle three to four times to bleed air from the system.
3. Stop the engine, remove the fuel tank (page 3-4) and add the coolant up to the filler neck.
4. Install the radiator cap.

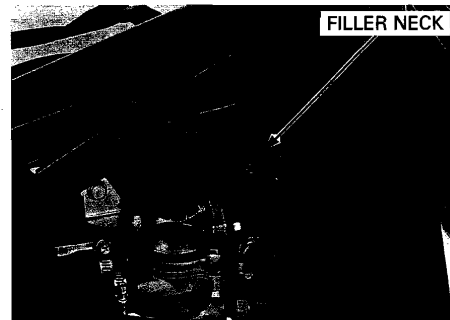

COOLING SYSTEM

Remove the reserve tank cap.
Fill the reserve tank to the upper level line and
install the tank cap.

Install the fuel tank (page 3-4).

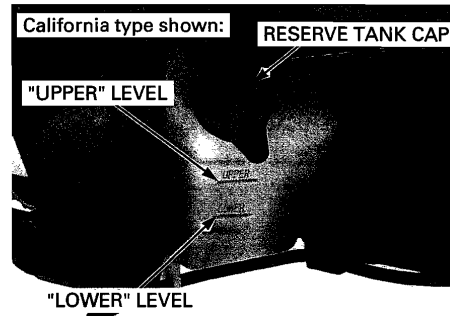

THERMOSTAT

REMOVAL

Drain the coolant from the system (page 7-7).
Remove the steering side covers (page 3-5).

Place a shop towel under the thermostat housing.

Disconnect the ECT sensor switch connector.
Remove the thermostat housing cover bolts.

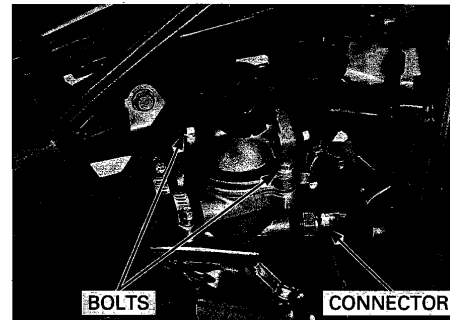

Pull out the thermostat housing and remove the O-ring and thermostat.

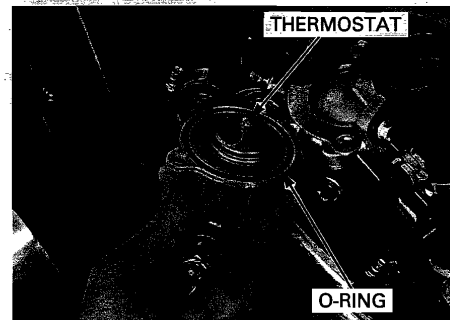

THERMOSTAT INSPECTION

Visually inspect the thermostat for damage.
Replace the thermostat if the valve stays open at
room temperature.

Wear insulated gloves and adequate eye protection.
Keep flammable materials away from the electric heating element.
Do not let the thermostat or thermometer touch the pan, or you will get false readings.

Heat a container of water with an electric heating element for 5 minutes.
Suspend the thermostat in the heated water to check its operation.

THERMOSTAT BEGIN TO OPEN:
80 – 84°C (176 – 183°F)

VALVE LIFT:
8 mm (0.3 in) minimum at 95°C (203°F)

Replace the thermostat if the valve opens at a temperature other than those specified.

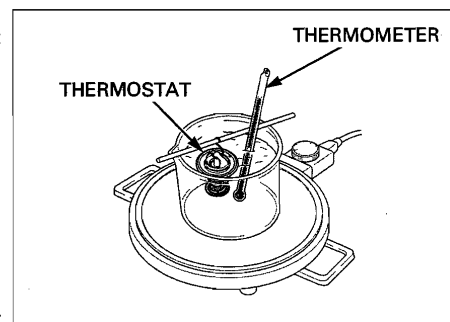

INSTALLATION

Install the thermostat by aligning its flange with the thermostat housing slot.

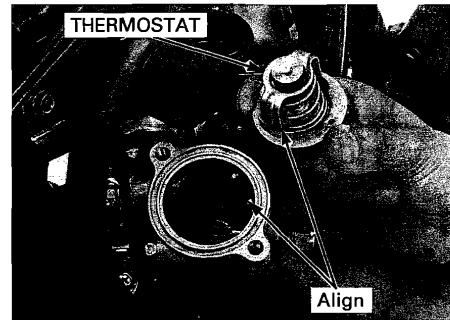

Install a new O-ring into the thermostat housing groove.



Install the thermostat housing to the cover and tighten the bolts to the specified torque.

TORQUE: 10 N-m (1.0 kgf-m, 7 lbf-ft)

Connect the ECT sensor switch connector.

Fill and bleed the cooling system (page 7-7).

Install the steering side covers (page 3-5).

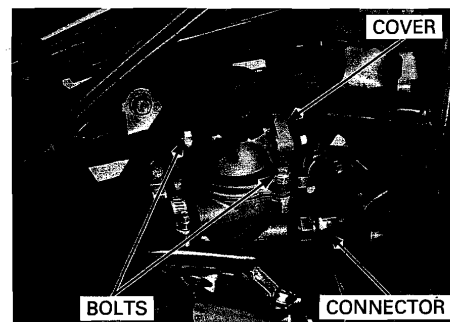
**THERMOSTAT HOUSING****REMOVAL/INSTALLATION**

Drain the coolant from the system (page 7-7).
Remove the steering side covers (page 3-5).

Disconnect the ECT sensor switch connector.
Loosen the water hose band screws and disconnect the water hoses.

Disconnect the siphon hose.

Remove the bolt and thermostat housing assembly.

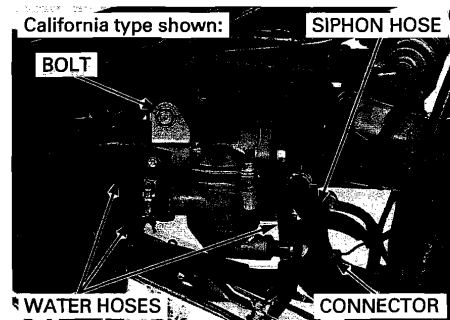

COOLING SYSTEM

Route the hoses and wires properly (page 1-22).

Install the thermostat housing assembly in the reverse order of removal.

NOTE:

Tighten the water hose band screws to the specified range as shown.

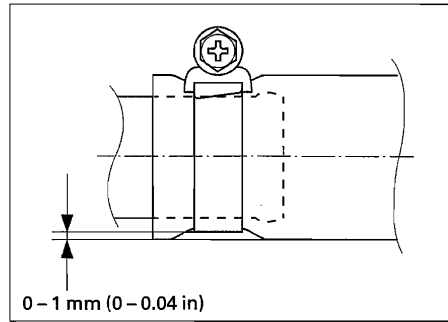

DISASSEMBLY

Remove the following:

- Thermostat housing (page 7-9)
- Thermostat (page 7-8)
- ECT sensor switch (page 21-13)

Remove the bolts and O-ring.

O-RING

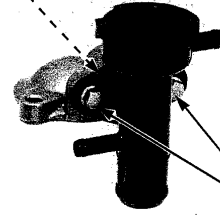

BOLTS

ASSEMBLY

Install a new O-ring to the radiator filler.

Assemble the radiator filler and thermostat housing cover.

RADIATOR FILLER

COVER



O-RING

Install and tighten the bolts to the specified torque.

TORQUE: 10 N-m (1.0 kgf-m, 7 lbf-ft)

Install the following:

- ECT sensor switch (page 21-13)
- Thermostat (page 7-9)
- Thermostat housing (page 7-9)

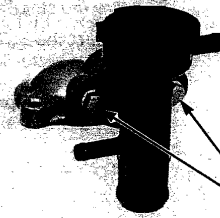

BOLTS

RADIATOR/COOLING FAN**REMOVAL**

Be careful not to damage the radiator fins while servicing the radiator and fan motor.

Drain the coolant from the system (page 7-7).
Remove the steering side covers (page 3-5).

Remove the wire band and disconnect the fan motor switch 2P (Natural) connector.

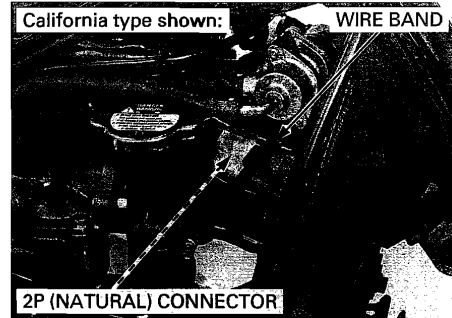

Loosen the water hose band screw and disconnect the radiator upper water hose.

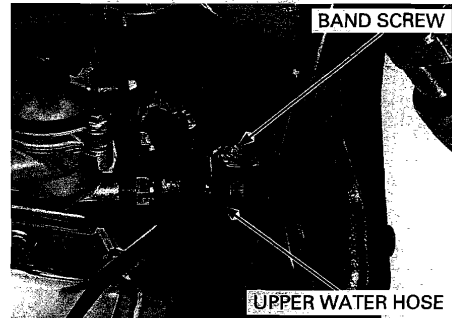

Loosen the water hose band screw and disconnect the radiator lower water hose.

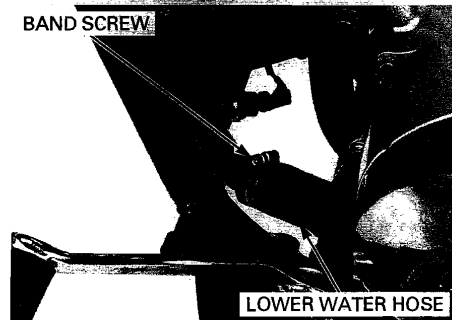

COOLING SYSTEM

Remove the bolt and collar.

Release the rear brake light switch and ignition pulse generator wires from the radiator grill.

Release the fan motor wire from the clamp and remove the radiator.

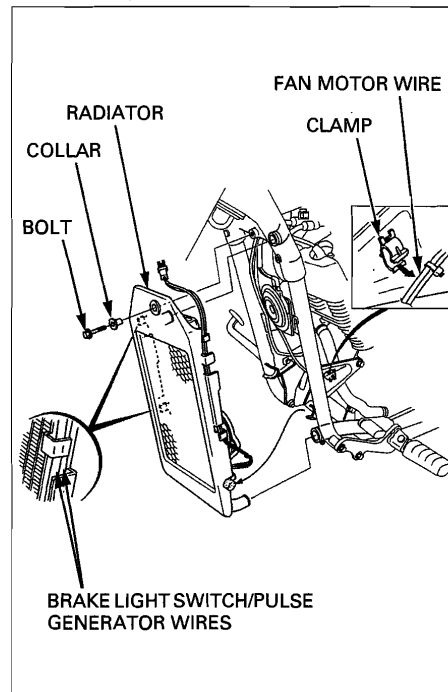

DISASSEMBLY

For fan motor switch inspection (page 21-14).

Release the fan motor wires from the radiator grill.

Remove the radiator mounting rubbers and radiator grill.

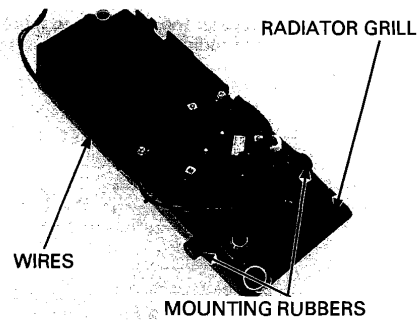

Disconnect the fan motor switch connector and release the wires from the clamp.

Remove the bolts, ground terminal and fan motor assembly.

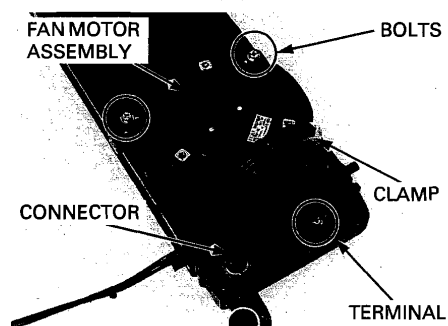

Remove the nut and cooling fan.

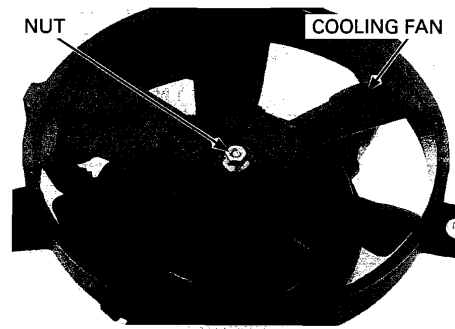

Remove the bolts and fan motor from the shroud.

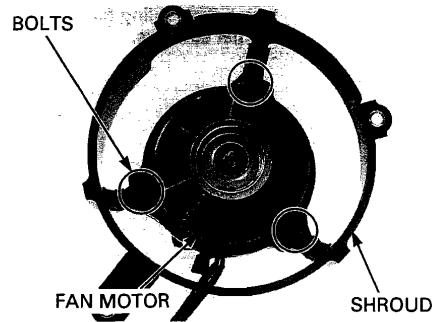

ASSEMBLY

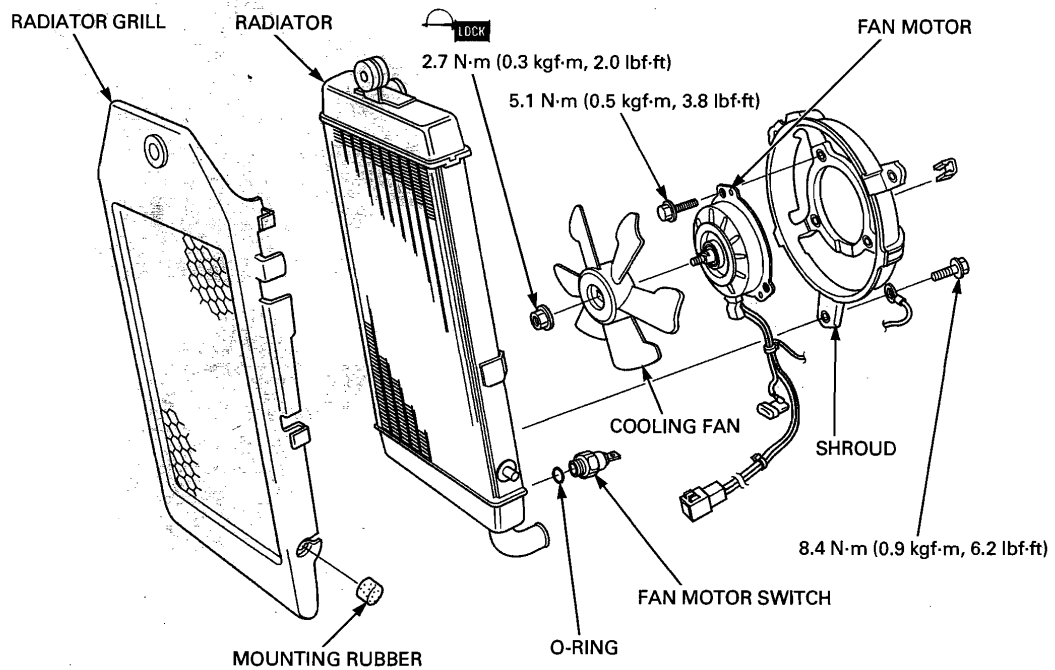

COOLING SYSTEM

Install the fan motor on the shroud in the direction as shown and tighten the bolts to the specified torque.

TORQUE: 5.1 N·m (0.5 kgf·m, 3.8 lbf·ft)

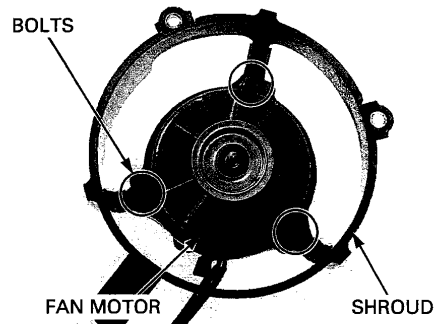

Install the cooling fan onto the motor shaft, aligning the flat surfaces.

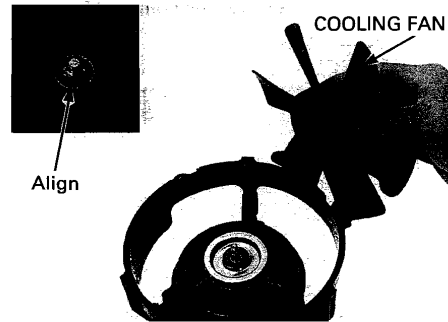

Clean and apply locking agent to the nut threads. Tighten the nut to the specified torque.

TORQUE: 2.7 N·m (0.3 kgf·m, 2.0 lbf·ft)

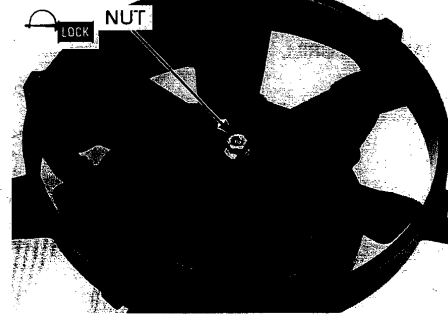

Install the fan motor assembly on the radiator and tighten the bolts with the ground terminal as shown.

TORQUE: 8.4 N·m (0.9 kgf·m, 6.2 lbf·ft)

Clamp the wires.

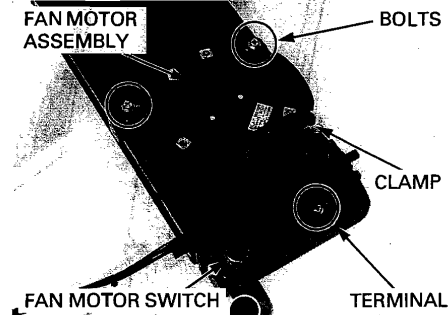

Install the radiator on the grill.
 Install the mounting rubbers.
 Route the fan motor wires through the shroud.

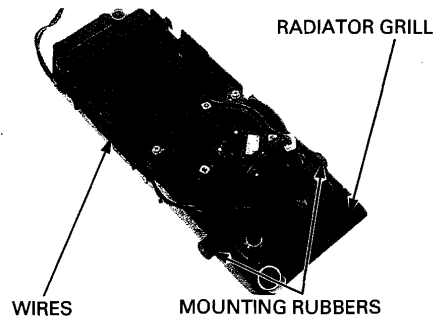

INSTALLATION

Install the radiator by inserting its mounting rubbers into the holder of the frame.

Route the rear brake light switch and ignition pulse generator wires through the radiator grill (page 1-22).

Connect the fan motor switch wire to the clamp.

Install the collar, bolt and tighten the bolt.

Connect the radiator upper and lower water hoses (page 1-22).

Tighten the water hose band screws to the specified range (page 7-10).

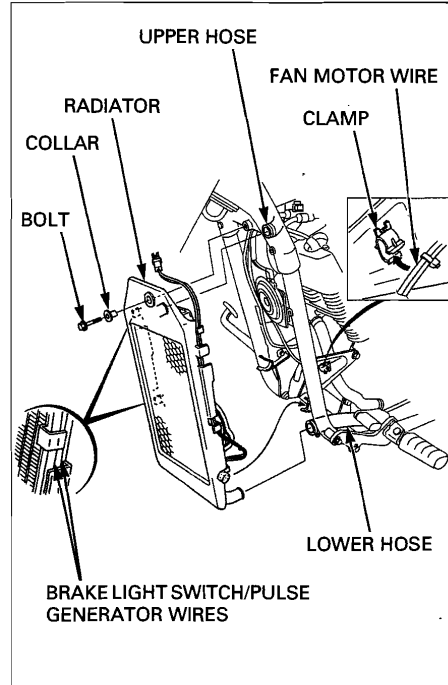

Route the wire properly (page 1-22).

Connect the fan motor switch 2P (Natural) connector and install the wire band.

Install the steering side covers (page 3-5).
 Fill and bleed the cooling system (page 7-7).

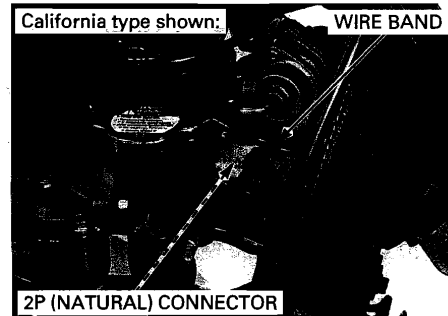

COOLING SYSTEM

WATER PUMP

MECHANICAL SEAL INSPECTION

Inspect the telltale hole for signs of coolant leakage. If there is leakage, the water pump mechanical seal is defective and the water pump should be replaced.

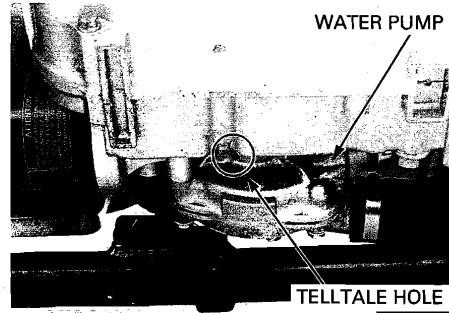

REMOVAL

Drain the coolant from the system (page 7-7).

Loosen the water hose band screw and disconnect the water hose.

Remove the bolts, sealing washer and water pump cover.

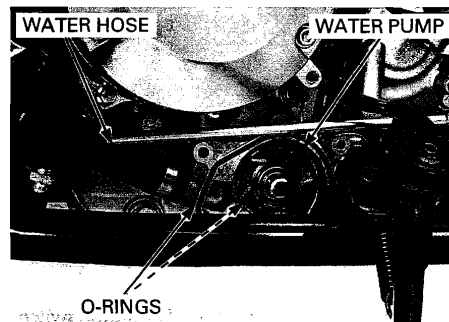
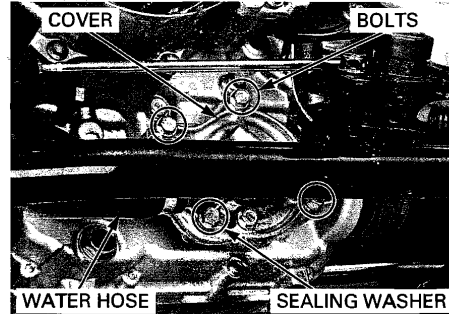

Disconnect the water hose.
Remove the O-rings and water pump.

INSTALLATION

Coat a new O-ring with engine oil and install it onto the stepped section of the water pump.

Install the water pump while aligning its groove with the projection of the oil pump shaft.

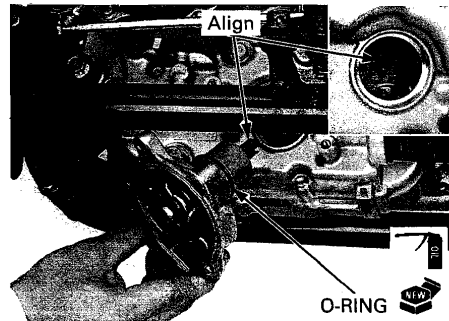

Connect the water hose (page 1-22).
Tighten the water hose band screw to the specified range (page 7-10).

Install a new O-ring into the groove in the water pump.

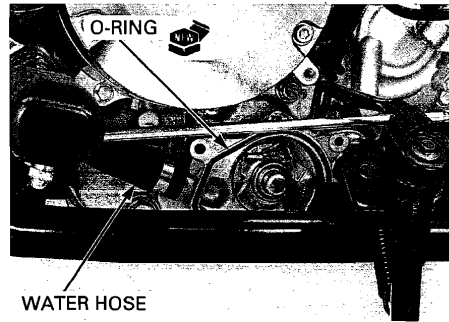

Align the bolt holes in the pump and crankcase, then install the water pump cover with the bolts and a new sealing washer.
Tighten the bolts to the specified torque in a criss-cross pattern in several steps.

TORQUE: 13 N·m (1.3 kgf·m, 10 lbf·ft)

Connect the water hose (page 1-22) and tighten the water hose band screw to the specified range (page 7-10).

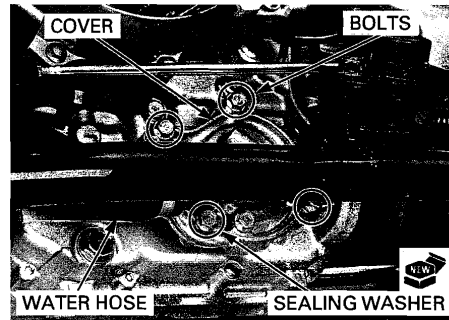

RADIATOR RESERVE TANK

REMOVAL/INSTALLATION

Disconnect the siphon hose from the reserve tank and drain the coolant.

Remove the bolt and reserve tank.

Installation is in the reverse order of removal.

Route the hoses properly (page 1-22).

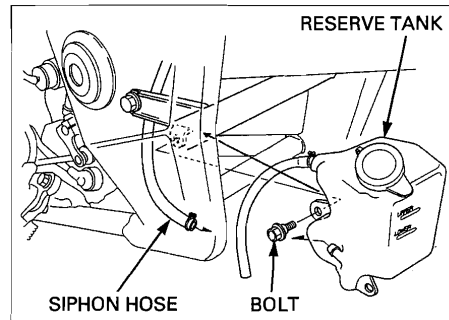

8. ENGINE REMOVAL/INSTALLATION

COMPONENT LOCATION	8-2	ENGINE REMOVAL	8-4
SERVICE INFORMATION	8-3	ENGINE INSTALLATION	8-7

COMPONENT LOCATION

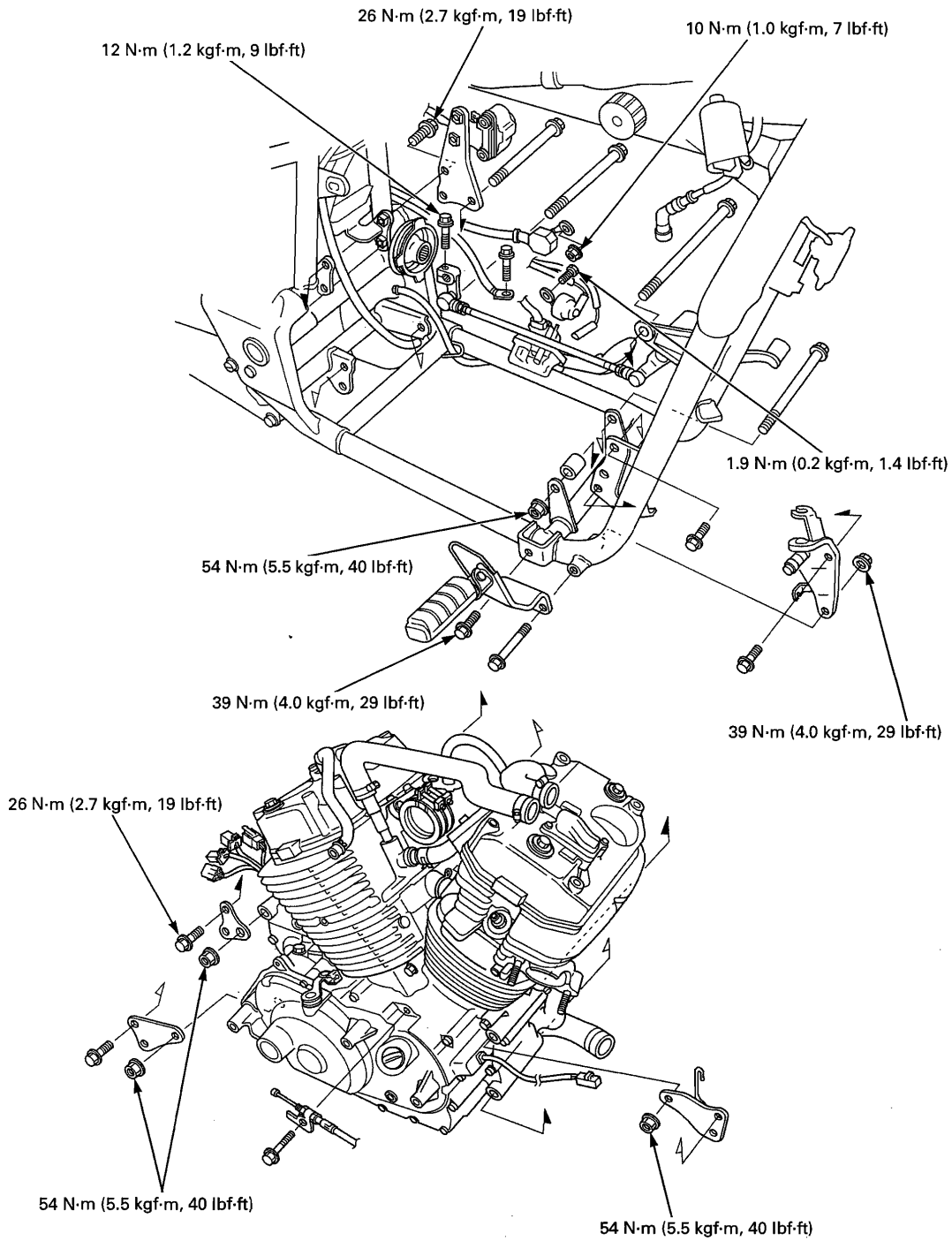

SERVICE INFORMATION**GENERAL**

- A hoist or equivalent is required to support the motorcycle when removing and installing the engine.
- A floor jack or other adjustable support is required to support and maneuver the engine.
- When installing the engine, be sure to tighten the engine mounting fasteners to the specified torque in the specified sequence. If you make a mistake with the tightening torque or sequence, loosen all mounting fasteners, then tighten them again to the specified torque in the correct sequence.
- Do not support the engine using the engine oil filter or it will be damaged.
- When removing/installing the engine, tape the frame around the engine beforehand for frame protection.
- The following components require engine removal for servicing.
 - Cylinder head (page 9-14)
 - Cylinder/piston (page 10-4)
 - Crankshaft (page 13-10)
 - Transmission (Including gearshift drum/shift fork: page 13-20)
 - Output gear case (page 13-28)
 - Oil pump (page 5-6)
- The following components can be serviced with the engine in the frame.
 - Camshaft (page 9-8)
 - Carburetor (page 6-7)
 - Water pump (page 7-16)
 - Clutch/gearshift linkage (page 11-3)
 - Alternator/starter clutch (page 12-3)
 - Starter motor (page 20-6)

SPECIFICATIONS

ITEM	SPECIFICATIONS
Engine dry weight	72.3 kg (159.4 lbs)
Engine oil capacity at disassembly	3.2 liters (3.4 US qt, 2.8 Imp qt)
Coolant capacity (radiator and engine)	1.58 liters (1.67 US qt, 1.39 Imp qt)

TORQUE VALUES

Engine mounting nut	54 N·m (5.5 kgf·m, 40 lbf·ft)
Engine hanger plate bolt	26 N·m (2.7 kgf·m, 19 lbf·ft)
Starter motor cable terminal nut	10 N·m (1.0 kgf·m, 7 lbf·ft)
EOP switch terminal screw	1.9 N·m (0.2 kgf·m, 1.4 lbf·ft)
Main footpeg bracket mounting bolt	39 N·m (4.0 kgf·m, 29 lbf·ft)
Main footpeg bracket mounting nut	39 N·m (4.0 kgf·m, 29 lbf·ft)
Gearshift arm pinch bolt	12 N·m (1.2 kgf·m, 9 lbf·ft)

ENGINE REMOVAL

Drain the engine oil (page 4-13).
Drain the coolant from the cooling system (page 7-7).

Remove the following:

- Fuel tank (page 3-4)
- Spark plug caps (page 4-9)
- Thermostat housing (page 7-9)
- Rear brake light switch (page 21-18)
- Brake pedal (page 16-17)
- Left crankcase rear cover (page 3-5)
- Exhaust system (page 3-8)
- Carburetor (page 6-7)
- Radiator (page 7-11)
- Over head covers (page 9-6)
- Clutch cover (page 11-5)
- Alternator cover (page 4-10)

NOTE:

Wrap the intake manifold port with a shop towel or cover them with a piece of tape to prevent any foreign material from dropping into the engine.

Disconnect the following connectors:

- Ignition switch 2P (Black) and 1P (Natural)
- VS sensor 3P (Natural)
- Alternator 3P (Natural)

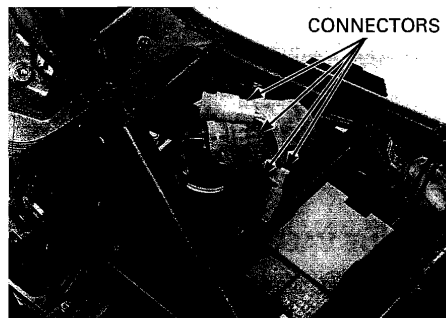

Disconnect the ignition pulse generator 2P (Red) connector.



Release the wires from the clamps and wire bands.
Disconnect the neutral switch connector.
Disconnect the EOP switch wire by removing the terminal screw.

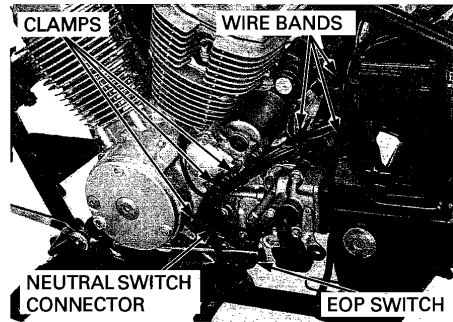

Remove the pinch bolt and gearshift arm.

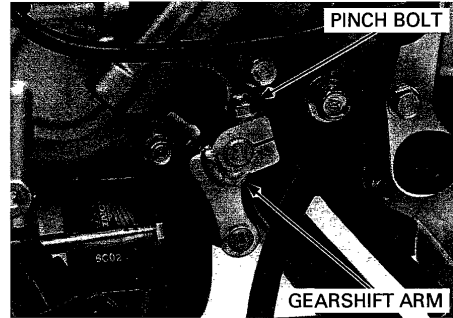

Disconnect the secondary air supply hoses from the PAIR check valve covers.



Remove the clutch cable holder by removing the bolt and disconnect the clutch cable end from the clutch lifter arm.

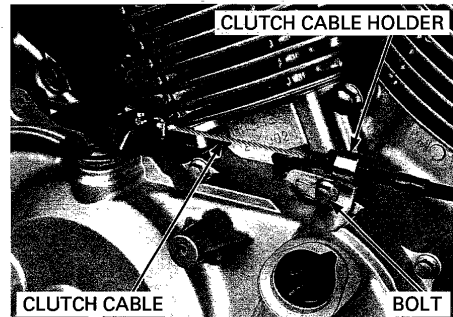

ENGINE REMOVAL/INSTALLATION

Open the terminal cover and remove the starter motor terminal nut.
Disconnect the starter motor cable.
Remove the bolt and disconnect the ground cable.

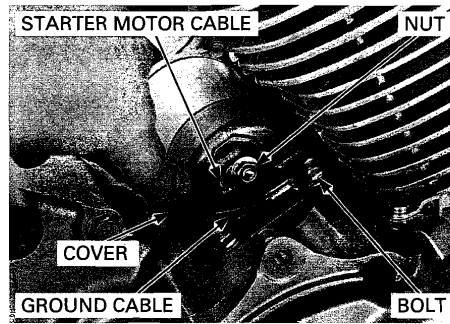

Remove the bolts, nut, right main footpeg and brake pedal brackets from the frame.

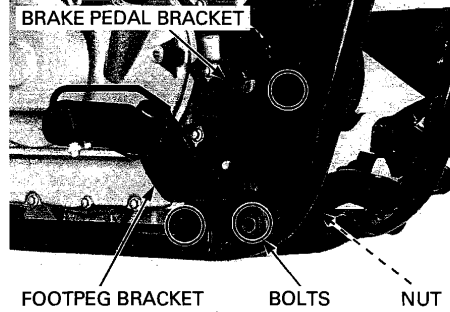

The jack height must be continually adjusted to relieve stress for bolt removal.

Place a floor jack or other adjustable support under the engine.

Remove the rear engine mounting nuts.
Remove the bolts and right rear engine hanger plates.

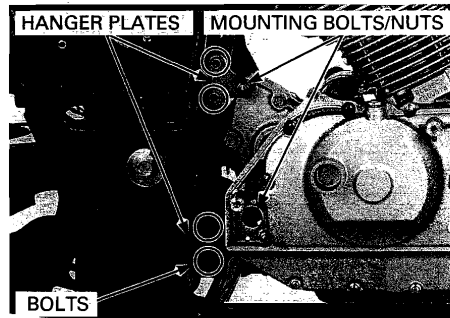

Remove the rear engine mounting bolts.
Remove the bolts and left rear engine hanger plate.

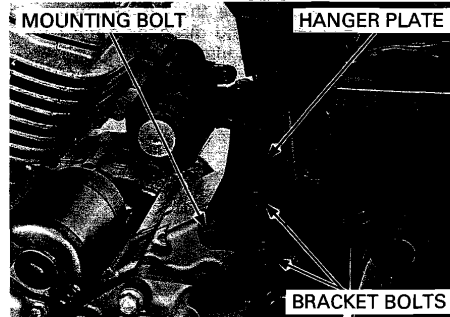

Remove the front engine mounting nuts.
Remove the bolts and front engine hanger plate.
Remove the engine mounting bolts and collar.

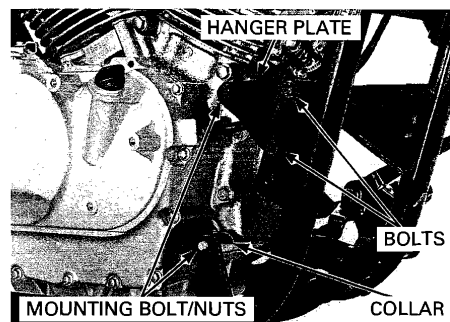

Release the joint boot from the output gear case.

During engine removal, hold the engine securely and be careful not to damage the frame and engine.

Move the engine forward and release the output shaft from the universal joint in the swingarm. Carefully maneuver the engine and remove it out of the frame to the right.

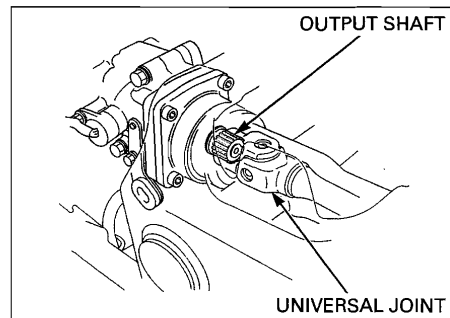

ENGINE INSTALLATION

NOTE:

- Note the direction of engine hanger bolts.
- All the engine mounting bolts and nuts loosely install, then tighten the bolts and nuts to the specified torque in the specified sequence.
- Be sure to tighten all engine mounting fasteners to the specified torque in the specified sequence. If you make a mistake with the tightening torque or sequence, loosen all mounting fasteners, then tighten them again to the specified torque in the correct sequence.
- Route the wires, hoses and cables properly (page 1-22).

During engine installation, hold the engine securely and be careful not to damage the frame and engine.

Using a floor jack or other adjustable support, carefully place the engine into the frame and maneuver it into place.

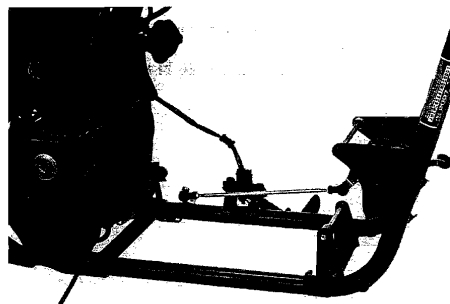

ENGINE REMOVAL/INSTALLATION

Carefully align the mounting points. Apply 1 g of molybdenum disulfide paste to the output shaft splines (universal joint side). Engage the output shaft with the universal joint.

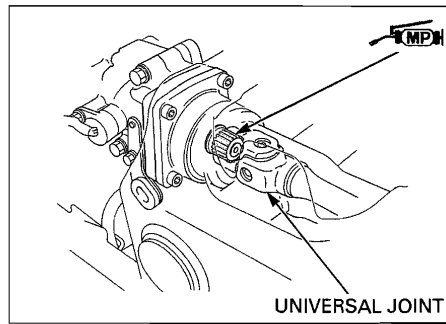

Loosely install all engine hanger plates, mounting fasteners and collar.

Tighten the front lower, then front upper engine mounting nuts to the specified torque.

TORQUE: 54 N-m (5.5 kgf-m, 40 lbf-ft)

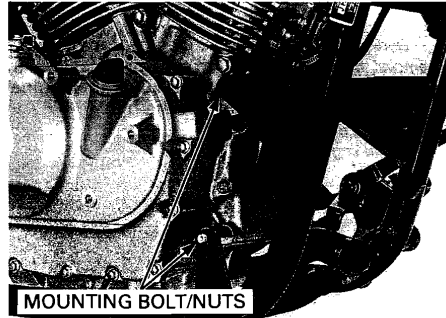

Tighten the rear lower, then rear upper engine mounting nuts to the specified torque.

TORQUE: 54 N-m (5.5 kgf-m, 40 lbf-ft)

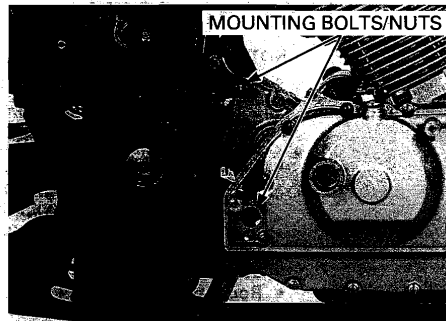

Tighten the front engine hanger plate bolts to the specified torque.

TORQUE: 26 N-m (2.7 kgf-m, 19 lbf-ft)

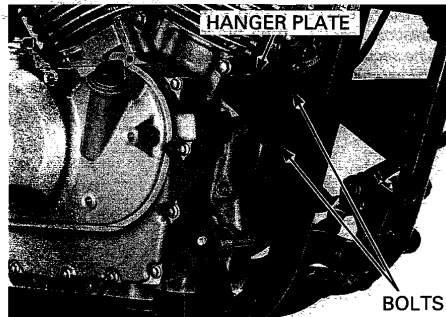

Tighten the right rear lower engine hanger plate bolts to the specified torque.

TORQUE: 26 N·m (2.7 kgf·m, 19 lbf·ft)

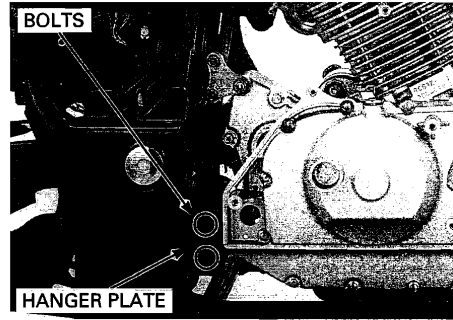

Tighten the left rear upper engine hanger plate bolts to the specified torque.

TORQUE: 26 N·m (2.7 kgf·m, 19 lbf·ft)

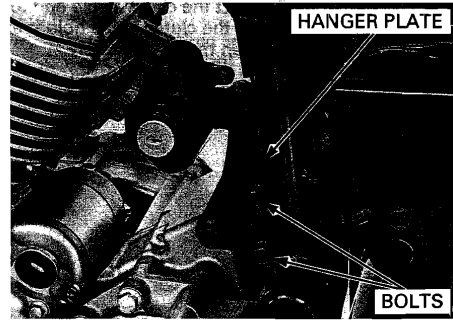

Tighten the right rear upper engine hanger plate bolts to the specified torque.

TORQUE: 26 N·m (2.7 kgf·m, 19 lbf·ft)

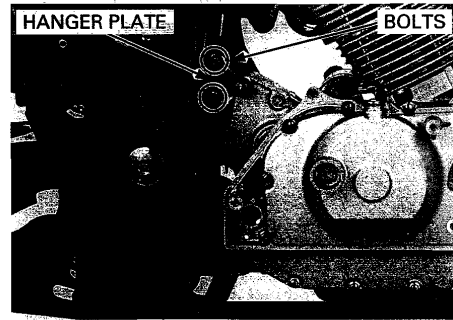

Install the right main footpeg and brake pedal brackets and tighten the bolts and nut to the specified torque.

TORQUE:

**Main footpeg bracket mounting bolt/nut:
39 N·m (4.0 kgf·m, 29 lbf·ft)**

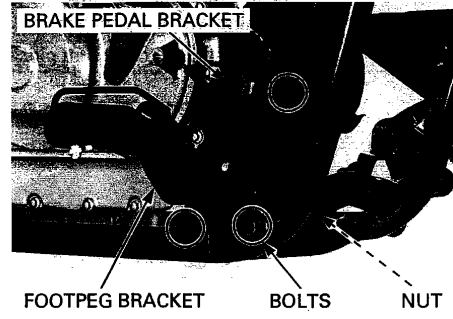

ENGINE REMOVAL/INSTALLATION

Connect the starter motor cable and tighten the terminal nut to the specified torque.

TORQUE: 10 N·m (1.0 kgf·m, 7 lbf·ft)

Connect the ground cable and tighten the bolt securely.

Close the terminal cover securely.

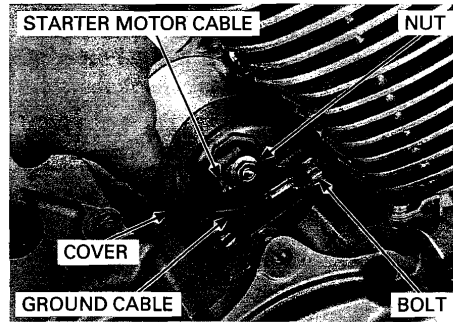

Connect the clutch cable end to the clutch lifter arm. Install the clutch cable holder and bolt. Tighten the bolt securely.

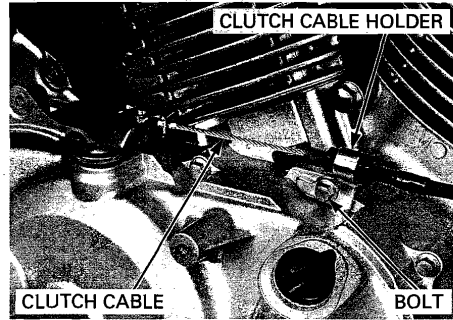

Connect the secondary air supply hoses to the PAIR check valve covers.

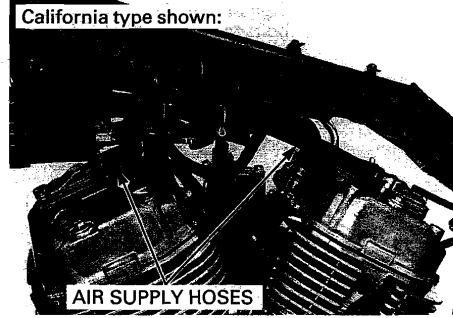

Install the gearshift arm to the gearshift spindle, aligning with the punch marks.

Tighten the gearshift arm pinch bolt to the specified torque.

TORQUE: 12 N·m (1.2 kgf·m, 9 lbf·ft)

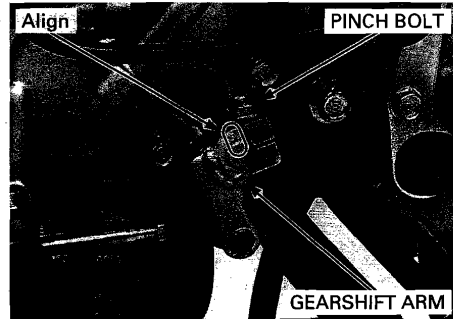

Clamp and bind the wires with the clamps and wire bands.

Connect the neutral switch connector.
Connect the EOP switch wire by tightening the terminal screw to the specified torque.

TORQUE: 1.9 N·m (0.2 kgf·m, 1.4 lbf·ft)

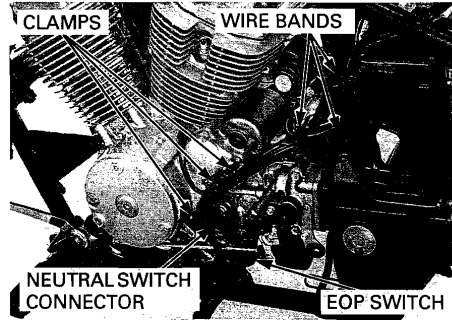

Connect the ignition pulse generator 2P (Red) connector.



Connect the following connectors:

- Ignition switch 2P (Black) and 1P (Natural)
- VS sensor 3P (Natural)
- Alternator 3P (Natural)

Install the following:

- Radiator (page 7-15)
- Carburetor (page 6-21)
- Exhaust system (page 3-11)
- Left crankcase rear cover (page 3-5)
- Spark plug caps (page 4-10)
- Thermostat housing (page 7-9)
- Rear brake light switch (page 21-18)
- Brake pedal (page 16-19)
- Over head covers (page 9-31)
- Clutch cover (page 11-22)
- Alternator cover (page 4-12)
- Fuel tank (page 3-4)

Fill the crankcase with engine oil (page 4-13).
Fill and bleed the cooling system (page 7-7).

Check the engine oil level (page 4-12).

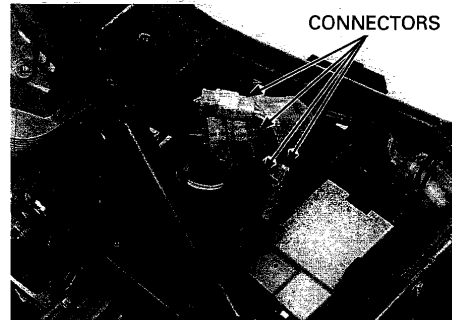

9. CYLINDER HEAD/VALVE

COMPONENT LOCATION	9-2	CYLINDER HEAD DISASSEMBLY	9-15
SERVICE INFORMATION	9-3	VALVE GUIDE REPLACEMENT	9-18
TROUBLESHOOTING	9-5	VALVE SEAT INSPECTION/REFACING	9-19
CYLINDER COMPRESSION.....	9-6	CYLINDER HEAD ASSEMBLY	9-22
CYLINDER HEAD COVER REMOVAL	9-6	CYLINDER HEAD INSTALLATION.....	9-24
CAMSHAFT REMOVAL	9-8	CAMSHAFT INSTALLATION	9-26
CYLINDER HEAD REMOVAL	9-14	CYLINDER HEAD COVER INSTALLATION	9-31

CYLINDER HEAD/VALVE COMPONENT LOCATION

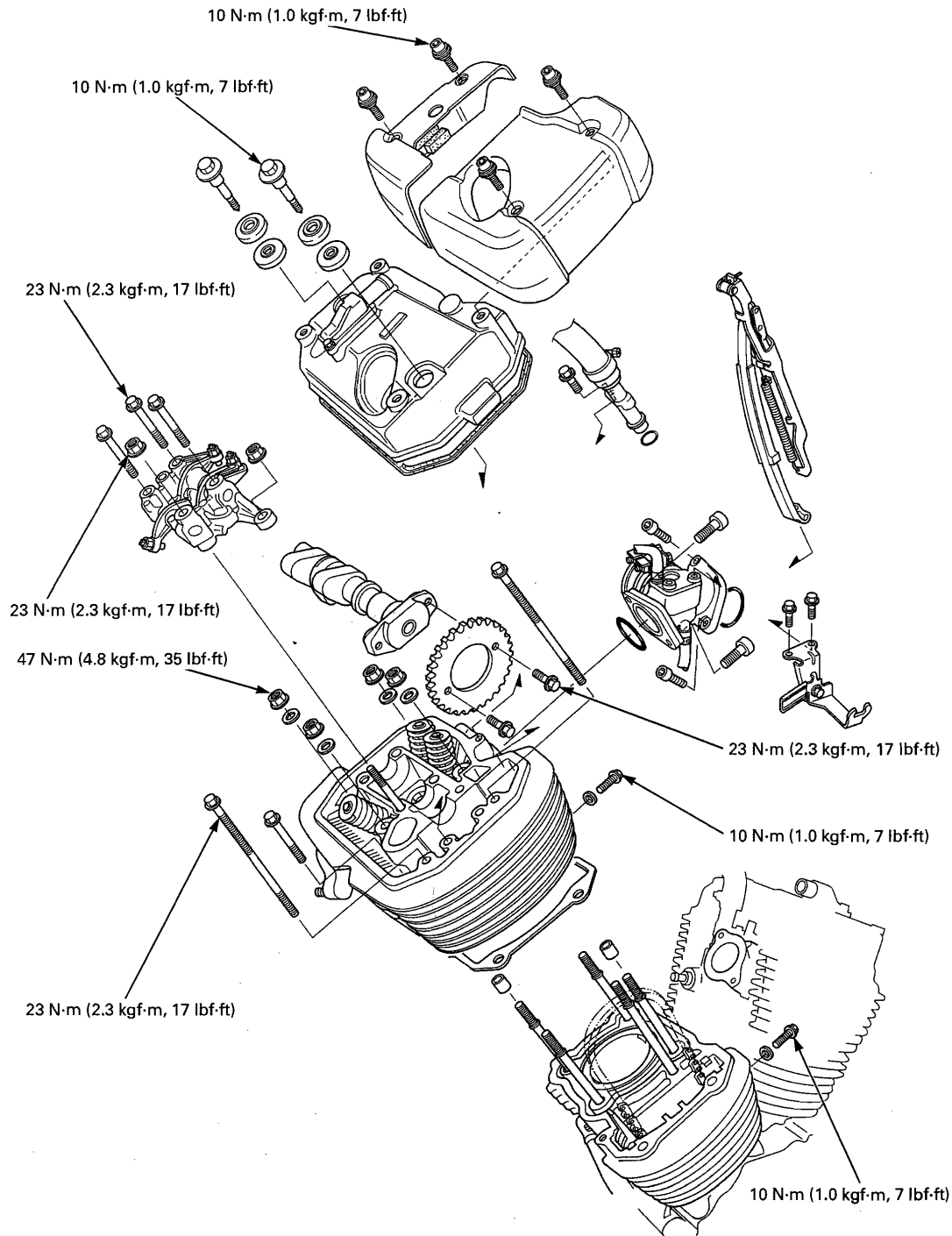

SERVICE INFORMATION**GENERAL**

- This section covers service of the rocker arm, camshaft, cylinder head and valve.
- The rocker arm and camshaft services can be done with the engine installed in the frame. The cylinder head and valve service requires engine removal.
- Be careful not to damage the mating surfaces when removing the cylinder head cover and cylinder head. Do not strike the cylinder head cover and cylinder head too hard during removal.
- When disassembling, mark and store the disassembled parts to ensure that they are reinstalled in their original locations.
- Clean all disassembled parts with cleaning solvent and dry them by blowing them off with compressed air before inspection.
- Camshaft and rocker arm lubricating oil is fed through oil passages in the cylinder head and camshaft holder. Clean the oil passages before assembling the cylinder head and cover.

SPECIFICATIONS

Unit: mm (in)

ITEM		STANDARD	SERVICE LIMIT
Cylinder compression at 400 rpm		1,373 ± 98 kPa (14.0 ± 1.0 kgf/cm ² , 199 ± 14 psi)	-
Valve clearance	IN	0.15 ± 0.02 (0.006 ± 0.001)	-
	EX	0.20 ± 0.02 (0.008 ± 0.001)	-
Cam chain tensioner wedge B length		-	6 (0.2)
Camshaft	Cam lobe height	IN	37.188 – 37.348 (1.4641 – 1.4704)
		EX	37.605 – 37.765 (1.4805 – 1.4868)
	Runout	IN/EX	-
	Journal O.D.	IN/EX	21.959 – 21.980 (0.8645 – 0.8654)
	Oil clearance	IN/EX	0.020 – 0.141 (0.0008 – 0.0056)
Rocker arm, rocker arm shaft	Rocker arm shaft O.D.	IN/EX	11.966 – 11.984 (0.4711 – 0.4718)
	Rocker arm I.D.	IN/EX	12.000 – 12.018 (0.4724 – 0.4731)
	Rocker arm-to-shaft clearance		0.016 – 0.052 (0.0006 – 0.0020)
Valve, valve guide	Valve stem O.D.	IN	5.475 – 5.490 (0.2156 – 0.2161)
		EX	5.455 – 5.470 (0.2148 – 0.2154)
	Valve guide I.D.	IN	5.500 – 5.510 (0.2165 – 0.2169)
		EX	5.500 – 5.512 (0.2165 – 0.2170)
	Stem-to-guide clearance	IN	0.010 – 0.035 (0.0004 – 0.0014)
		EX	0.030 – 0.057 (0.0012 – 0.0022)
	Valve guide projection above cylinder head	IN	18.7 – 18.9 (0.736 – 0.744)
EX		17.2 – 17.4 (0.68 – 0.69)	
Valve seat width	IN/EX	0.90 – 1.10 (0.035 – 0.043)	
	Valve spring	Free length	IN
EX			46.11 (1.815)
Cylinder head warpage		-	0.10 (0.004)

NEW







TORQUE VALUES

Cylinder head cover bolt	10 N·m (1.0 kgf·m, 7 lbf·ft)
Cylinder head 10 mm nut	47 N·m (4.8 kgf·m, 35 lbf·ft)
Cylinder head 8 mm bolt	23 N·m (2.3 kgf·m, 17 lbf·ft)
Cam sprocket bolt	23 N·m (2.3 kgf·m, 17 lbf·ft)
Cam chain tensioner bolt	10 N·m (1.0 kgf·m, 7 lbf·ft)
Camshaft holder bolt	23 N·m (2.3 kgf·m, 17 lbf·ft)
Camshaft holder nut	23 N·m (2.3 kgf·m, 17 lbf·ft)
Over head cover socket bolt	10 N·m (1.0 kgf·m, 7 lbf·ft)
Rear PAIR check valve cover bolt	7 N·m (0.7 kgf·m, 5.2 lbf·ft)

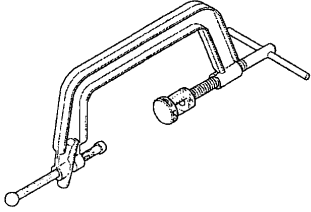
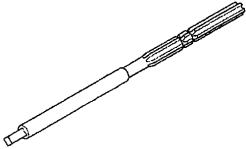
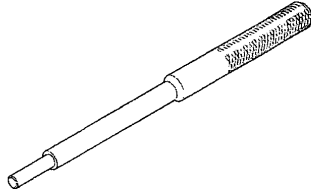
Apply engine oil to the threads and seating surface
 Apply engine oil to the threads and seating surface
 Apply locking agent to the threads
 See page 9-25

CYLINDER HEAD/VALVE

TOOLS

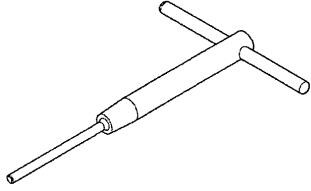
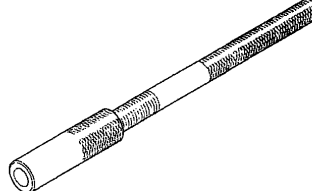
<p>Valve spring compressor 07757-0010000</p> 	<p>Valve guide reamer, 5.510 mm 07984-2000001</p>  <p>or 07984-200000D (U.S.A. only)</p>	<p>Valve guide driver, 5.5 mm 07742-0010100</p> 
<p>Seat cutter, 27.5 mm (45° IN) 07780-0010200</p>  <p>or equivalent commercially available in U.S.A.</p>	<p>Seat cutter, 35 mm (45° EX) 07780-0010400</p>  <p>or equivalent commercially available in U.S.A.</p>	<p>Flat cutter, 28 mm (32° IN) 07780-0012100</p>  <p>or equivalent commercially available in U.S.A.</p>
<p>Flat cutter, 35 mm (32° EX) 07780-0012300</p>  <p>or equivalent commercially available in U.S.A.</p>	<p>Interior cutter, 30 mm (60° IN) 07780-0014000</p>  <p>or equivalent commercially available in U.S.A.</p>	<p>Interior cutter, 37.5 mm (60° EX) 07780-0014100</p>  <p>or equivalent commercially available in U.S.A.</p>
<p>Cutter holder, 5.5 mm 07781-0010101</p>  <p>or equivalent commercially available in U.S.A.</p>	<p>Valve guide driver 07743-0020000</p>  <p>Not available in U.S.A.</p>	

TROUBLESHOOTING

Engine top-end problems usually affect engine performance. These can be diagnosed by a compression test, or by tracing top-end noise with a sounding rod or stethoscope.

Compression too low, hard starting or poor performance at low speed

- Valves
 - Incorrect valve adjustment
 - Burned or bent valves
 - Incorrect valve timing
 - Broken valve spring
 - Uneven valve seating
 - Valve stuck open
- Cylinder head
 - Leaking or damaged cylinder head gasket
 - Warped or cracked cylinder head
 - Loose spark plug
- Cylinder/piston problem (page 10-3)

Compression too high

- Excessive carbon build-up on piston head or combustion chamber

Excessive smoke

- Worn valve stem or valve guide
- Damaged stem seal
- Cylinder/piston problem (page 10-3)

Excessive noise

- Incorrect valve clearance
- Sticking valve or broken valve spring
- Excessive worn valve seat
- Worn or damaged camshaft
- Worn or damaged rocker arm and/or shaft
- Worn rocker arm follower or valve stem end
- Worn cam sprocket teeth
- Worn cam chain
- Worn or damaged cam chain tensioner
- Cylinder/piston problem (page 10-3)

Rough idle

- Low cylinder compression

CYLINDER COMPRESSION

NOTE:

If the engine must be running to do some work, make sure the area is well-ventilated. Never run the engine in an enclosed area.

To measure the cylinder compression of each cylinder, remove only one plug at a time.

Warm up the engine to normal operating temperature.

Stop the engine, disconnect the spark plug caps and remove one spark plug at a time.

Shift the transmission into neutral.

Install a compression gauge into the spark plug hole.

Open the throttle all the way and crank the engine with the starter motor until the gauge reading stops rising.

To avoid discharging the battery, do not operate the starter motor for more than seven seconds.

The maximum reading is usually reached within 4 – 7 seconds.

Compression pressure:

1,373 ± 98 kPa (14.0 ± 1.0 kgf/cm², 199 ± 14 psi) at 400 rpm

Low compression can be caused by:

- Blown cylinder head gasket
- Improper valve adjustment
- Valve leakage
- Worn piston ring or cylinder

High compression can be caused by:

- Carbon deposits in combustion chamber or on piston head

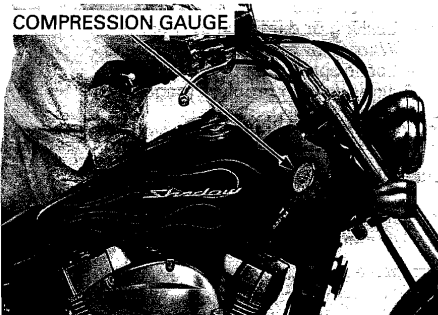

CYLINDER HEAD COVER REMOVAL

FRONT

Remove the fuel tank (page 3-4).

Disconnect the spark plug cap.

Remove the bolts and front right over head cover.

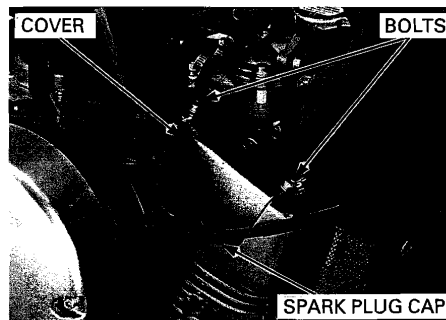

Disconnect the spark plug cap.
Remove the socket bolts and front left over head cover.

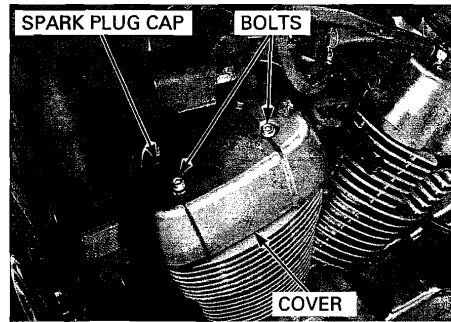

Disconnect the air supply hose.
Remove the cylinder head cover bolts, washers and rubber seals.

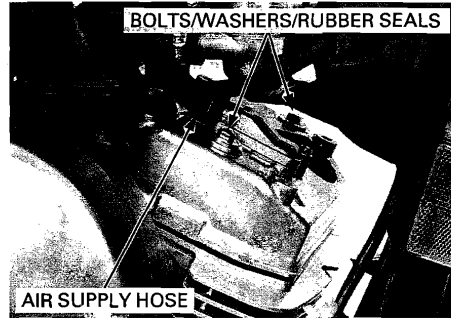

Be careful not to damage the wire harness and mating surfaces when removing the cylinder head cover.

Remove the cylinder head cover and gasket.

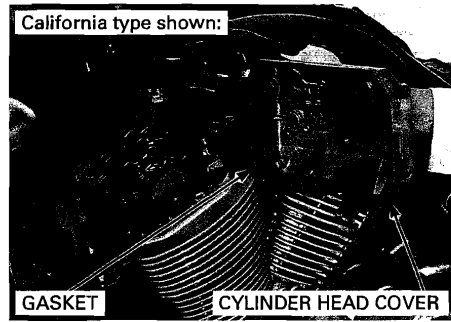

REAR

Remove the fuel tank (page 3-4).
Disconnect the spark plug cap.
Remove the socket bolts and rear right over head cover.

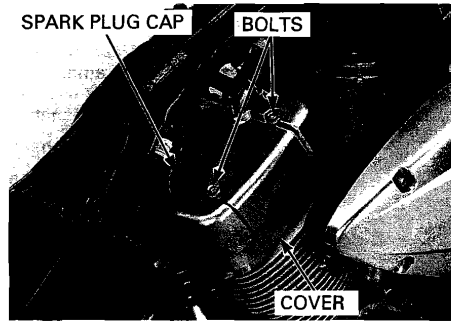

CYLINDER HEAD/VALVE

Disconnect the spark plug cap.
Remove the bolts, cover and rear PAIR check valve.
Remove the bolts and rear left over head cover.

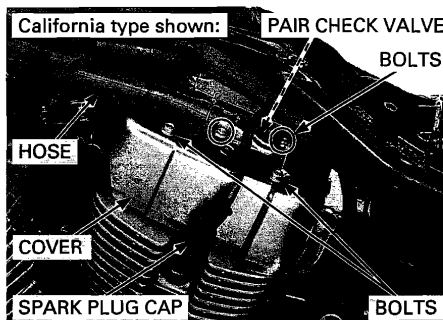

Disconnect the crankcase breather hose from the cylinder head cover.
Remove the cylinder head cover bolts, washers and rubber seals.

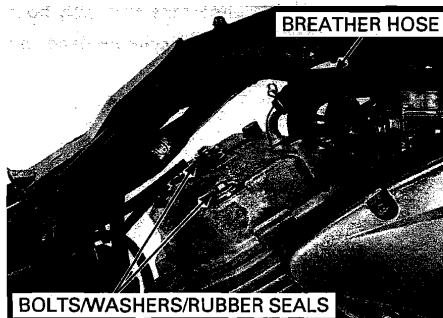

Be careful not to damage the wire harness and mating surfaces when removing the cylinder head cover.

Remove the cylinder head cover and gasket.

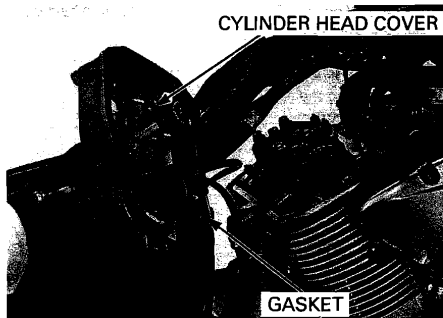

CAMSHAFT REMOVAL

NOTE:

- The camshaft can be serviced with the engine installed in the frame.
- The front camshaft uses the same service procedure as the rear camshaft.

Remove the rear cylinder head cover (page 9-7).
Remove the socket bolts and alternator cover.

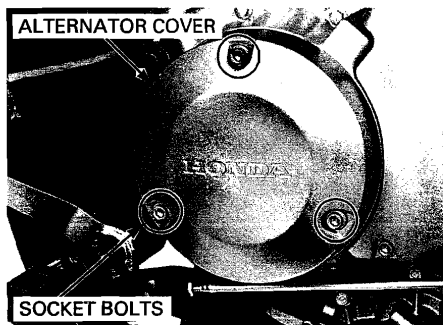

Remove the crankshaft and timing hole caps from the left crankcase cover.

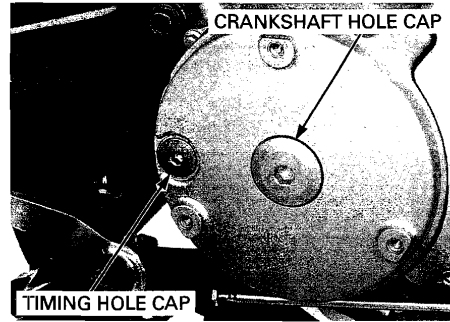

Turn the crankshaft counterclockwise and align the "RT" mark (front cylinder: "FT" mark) with the index notch on the left crankcase cover. Make sure the piston is at TDC (Top Dead Center) on the exhaust stroke so the piston is at TDC on the compression stroke when removing the camshaft holder.

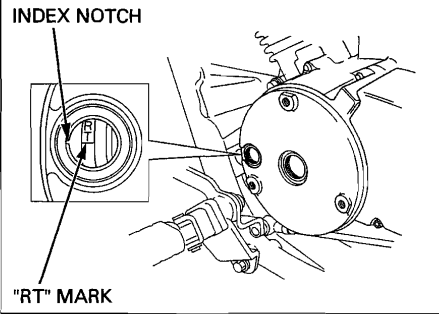

Measure the cam chain tensioner wedge B length as shown.

SERVICE LIMIT: 6 mm (0.2 in)

Replace the cam chain with a new one if the projection exceeds the service limit.

For the cam chain replacement, remove the following:

- Front:
- Front camshaft
 - Flywheel (page 12-5)
- Rear:
- Rear camshaft
 - Primary drive gear (page 11-12)

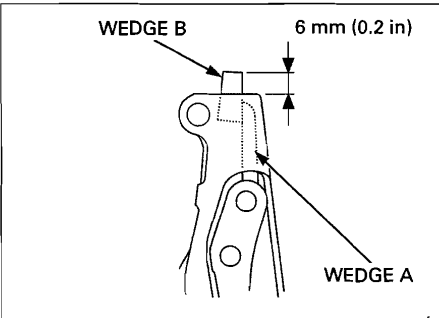

Be careful not to let the O.D. 2 mm pin fall into the crankcase.

Install an O.D. 2 mm pin into the cam chain tensioner wedge A hole while pulling the wedge A straight up and pushing down the wedge B.

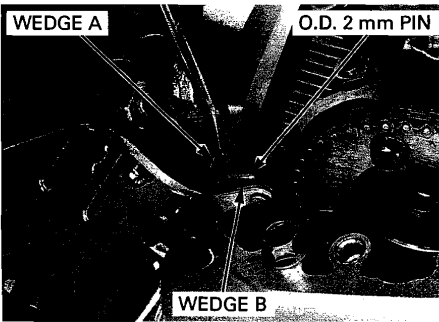

CYLINDER HEAD/VALVE

Be careful not to let the cam sprocket bolts fall into the crankcase.

Remove the cam sprocket bolt, turn the crankshaft counterclockwise one full turn (360°) and remove the other cam sprocket bolt.

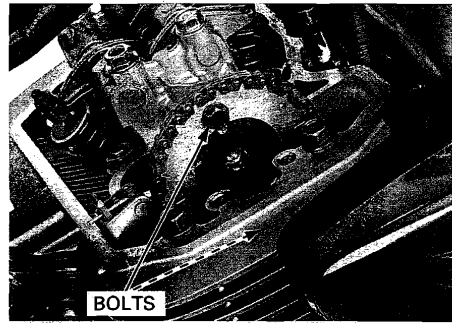

Attach a piece of wire to the cam chain to prevent it from falling into the crankcase.

Remove the cam sprocket from the camshaft flange surface.

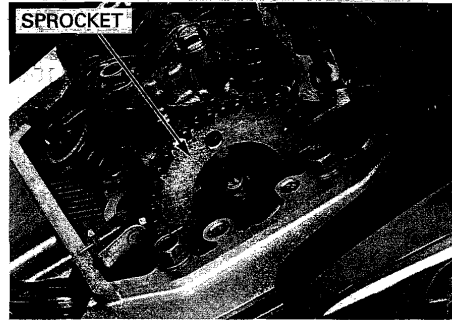

Make sure the piston is at TDC (Top Dead Center) on the compression stroke. Loosen the bolts and nuts in a crisscross pattern in several steps, then remove them and camshaft holder assembly.

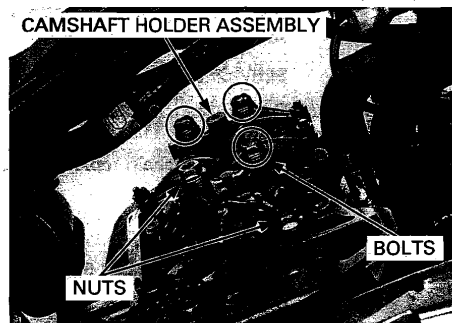

Remove the camshaft.

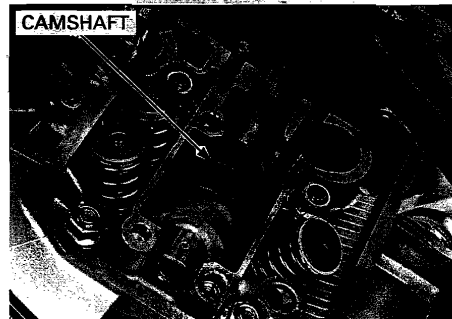

INSPECTION**CAMSHAFT RUNOUT**

Support both end journals of the camshaft with V-blocks and check the camshaft runout with a dial indicator.

Actual runout is 1/2 the total indicator reading.

SERVICE LIMIT: 0.05 mm (0.002 in)

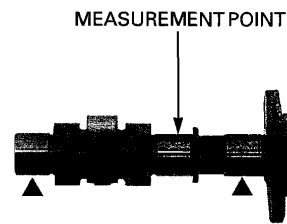
**CAM LOBE HEIGHT**

Check the cam lobe surfaces for scoring or evidence of insufficient lubrication.

Measure each cam lobe height.

SERVICE LIMITS: IN: 37.16 mm (1.463 in)

EX: 37.58 mm (1.480 in)

NOTE:

Check the rocker arm if the cam lobe is worn or damaged.

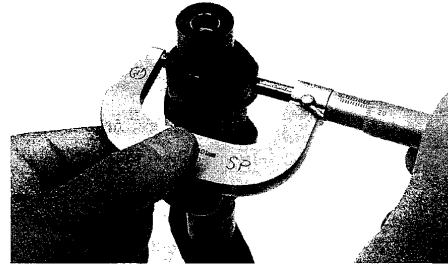
**CAMSHAFT JOURNAL**

Check the camshaft journal surfaces for scoring or evidence of insufficient lubrication.

Measure the O.D. of each camshaft journal.

SERVICE LIMIT: 21.90 mm (0.862 in)

NOTE:

Check the oil passages and camshaft holder for wear or damage if the journal surface is worn or damaged.

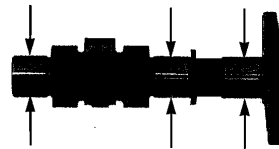
**CAM SPROCKET**

Check the cam sprocket for wear or damage.

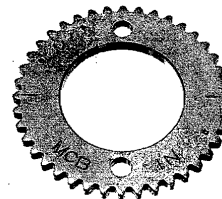

CYLINDER HEAD/VALVE

CYLINDER HEAD

Check the camshaft journal surfaces of cylinder head for scoring, scratches or evidence of insufficient lubrication.

JOURNAL SURFACES

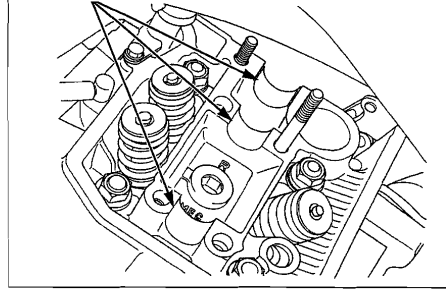

CAMSHAFT OIL CLEARANCE

Clean off any oil from the journals of the camshaft holders, cylinder head and camshaft.

Put the camshaft onto the cylinder head and lay a strip of plastigauge lengthwise on each camshaft journal.

NOTE:

- Do not block any oil passages with the plastigauge.
- Do not rotate the camshaft during inspection.

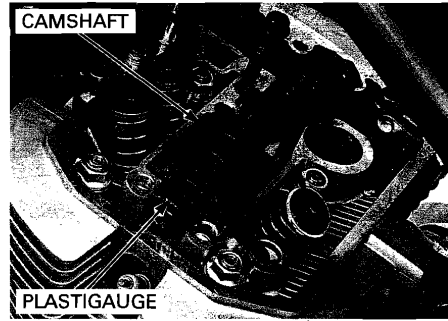

Carefully install the camshaft holder and tighten the camshaft holder bolts and nuts to the specified torque in a crisscross pattern in several steps.

TORQUE: 23 N·m (2.3 kgf·m, 17 lbf·ft)

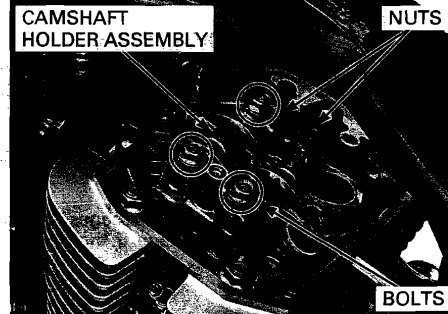

Remove the camshaft holder and measure the width of each plastigauge.

The widest thickness determines the oil clearance.

SERVICE LIMIT: 0.16 mm (0.006 in)

When the service limit is exceeded, replace the camshaft and recheck the oil clearance.

Replace the cylinder head and camshaft holder if the oil clearance still exceeds the service limit.

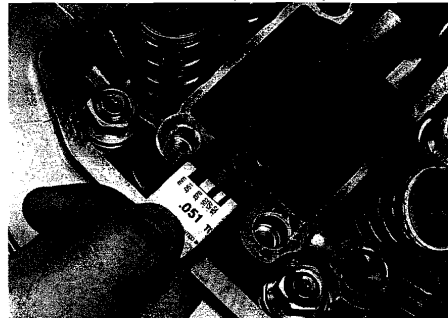

CAMSHAFT HOLDER DISASSEMBLY**NOTE:**

The front and rear cylinder camshaft holder service procedures are the same.

Remove the rocker arm shafts, intake and exhaust rocker arms.

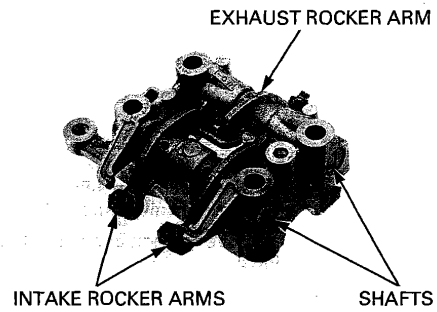
**ROCKER ARM INSPECTION**

Check the sliding surface of the rocker arms for wear or damage where they contact the camshaft, or for clogged oil holes.

Check the contact surface of the valve adjusting screw for wear or damage.

Measure the I.D. of each rocker arm.

SERVICE LIMIT: 12.05 mm (0.474 in)

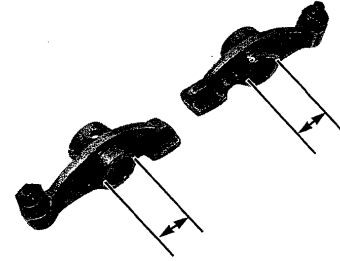
**ROCKER ARM SHAFT INSPECTION**

Check the rocker arm shafts for wear or damage.

Measure each rocker arm shaft O.D.

SERVICE LIMIT: 11.83 mm (0.466 in)

Calculate the rocker arm-to-shaft clearance.

SERVICE LIMIT: 0.07 mm (0.003 in)

Replace the rocker arm and/or shaft if necessary.

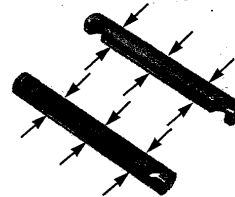
**CAMSHAFT HOLDER INSPECTION**

Check the camshaft journal surfaces of each camshaft holder for scoring, scratches or evidence of insufficient lubrication.

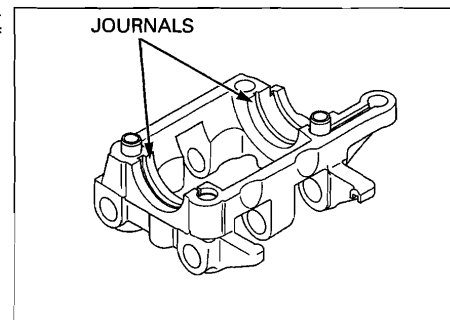

CYLINDER HEAD REMOVAL

NOTE:

- The engine must be removed from the frame before servicing the cylinder head.
- The front and rear cylinder head service procedures are the same.

Remove the following:

- Engine (page 8-4)
- Cylinder head cover (page 9-6)
- Camshaft (page 9-8)
- Intake manifold (page 6-23)

Remove the bolt and water hose joint from the cylinder.

Rear cylinder head only:

Disconnect the vacuum hose.

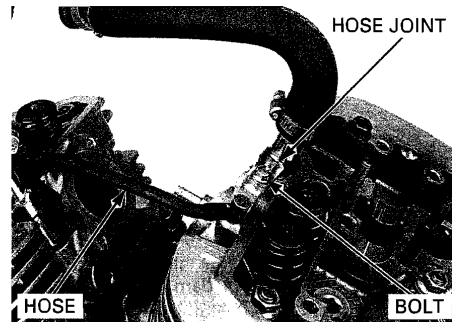

Remove the cam chain tensioner bolts and sealing washers.



Remove the cam chain tensioner.

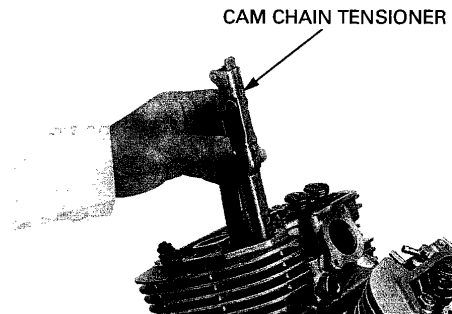

Loosen the bolts and nuts in a crisscross pattern in several steps.

Remove the following cylinder head bolts and nuts:

- 6 mm bolt
- 8 mm bolts
- 10 mm nuts/washers

Be careful not to damage the mating surface when removing the cylinder head.

Remove the cylinder head.

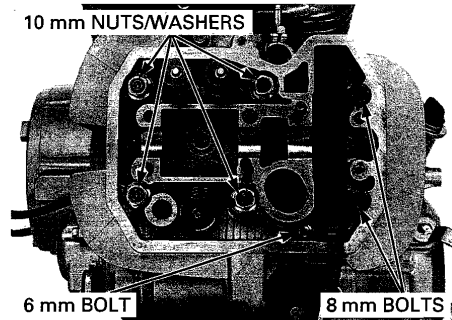

Remove the gasket and dowel pins.

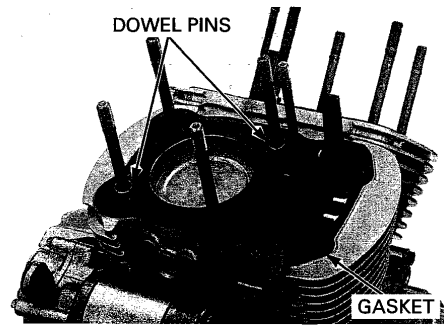

Remove the cam chain guide.

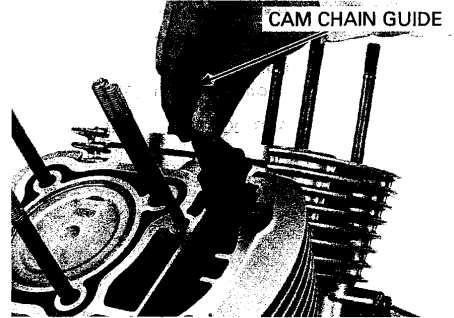

CYLINDER HEAD DISASSEMBLY

Mark all parts during disassembly so they can be placed back in their original position.

Remove the spark plugs (page 4-9).
Remove the cotters using a special tool.

TOOL:
Valve spring compressor 07757-0010000

NOTE:
Compressing the valve spring more than necessary will cause loss of valve spring tension.

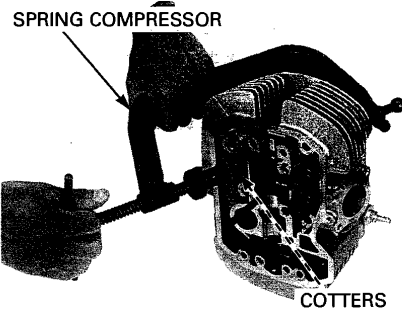

Do not reuse the removed stem seal.

Remove the valve spring compressor, then remove the retainer, spring and valve.
Remove the stem seal and spring seat.

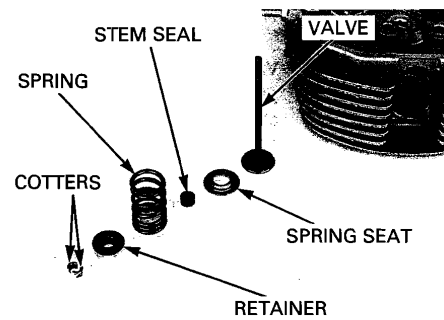

CYLINDER HEAD/VALVE

Remove the carbon deposits from the combustion chamber and clean off the head gasket surface.

Check the spark plug hole and valve areas for cracks.

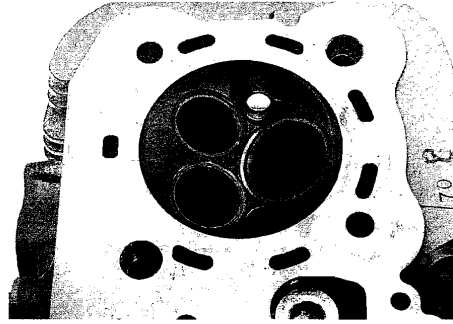

INSPECTION

CYLINDER HEAD

Check the cylinder head for warpage with a straight edge and feeler gauge.

SERVICE LIMIT: 0.10 mm (0.004 in)

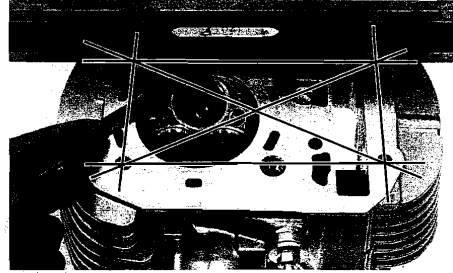

VALVE SPRING

Check the valve spring for fatigue or damage.

Measure the free length of each valve spring.

SERVICE LIMITS: IN: 40.58 mm (1.598 in)

EX: 44.72 mm (1.761 in)

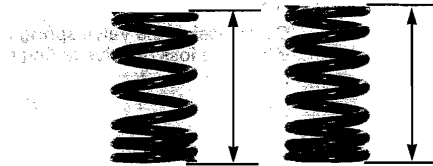

VALVE STEM

Check each valve for bending, burning, scratches or abnormal wear.

Insert the valves in their original positions in the cylinder head. Check that each valve moves up and down smoothly without binding.

Measure each valve stem O.D. and record it.

SERVICE LIMITS: IN: 5.45 mm (0.215 in)

EX: 5.41 mm (0.213 in)

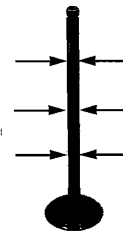

VALVE GUIDE

Ream the valve guide to remove any carbon build-up before measuring the guide I.D.

NOTE:

- Take care not to tilt or lean the reamer in the guide while reaming. Otherwise, the valves may be installed slanted, causing oil leakage from the stem seal and improper valve seat contact. This may prevent valve seat refacing.
- Insert the reamer from the combustion chamber side of the head and always rotate the reamer clockwise.

TOOLS:

Valve guide reamer
5.510 mm (IN/EX)

07984-2000001 or
07984-200000D
(U.S.A. only)

VALVE GUIDE REAMER

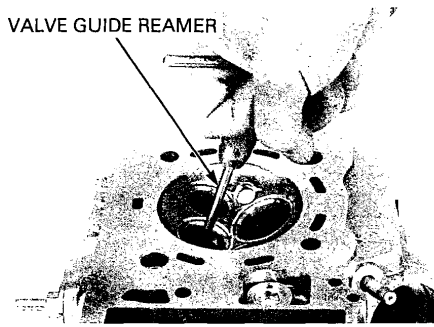

Measure each valve guide I.D. and record it.

SERVICE LIMITS: IN: 5.56 mm (0.219 in)
EX: 5.56 mm (0.219 in)

Subtract each valve stem O.D. from the corresponding guide I.D. to obtain the stem-to-guide clearance.

SERVICE LIMITS: IN: 0.10 mm (0.004 in)
EX: 0.11 mm (0.004 in)

If the stem-to-guide clearance exceeds the service limit, determine if a new guide with standard dimensions would bring the clearance within tolerance.

If so, replace any guides as necessary and ream to fit.

If the stem-to-guide clearance exceeds the service limit with a new guide, also replace the valve.

NOTE:

Inspect and reface the valve seats whenever the valve guides are replaced (page 9-19).

CAM CHAIN GUIDE

Check the cam chain guide for wear or damage.
Replace the cam chain guide if necessary.

CAM CHAIN GUIDE

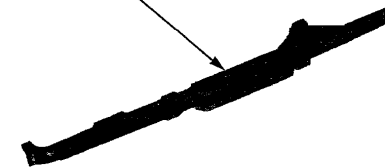

CYLINDER HEAD/VALVE

CAM CHAIN TENSIONER

Check the cam chain tensioner for wear or damage.
Replace the cam chain tensioner if necessary.

CAM CHAIN TENSIONER

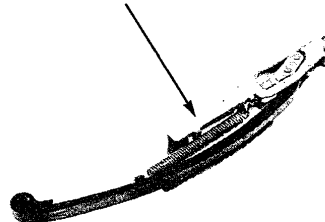

VALVE GUIDE REPLACEMENT

NOTE:

Refinish the valve seats whenever the valve guides are replaced to prevent uneven seating.

Chill new valve guides in the freezer section of a refrigerator for about an hour.

Do not use a torch to heat the cylinder head; it may cause warping.

Heat the cylinder head to 130 – 140°C (266 – 284°F) with a hot plate or oven. Do not heat the cylinder head beyond 150°C (302°F). Use temperature indicator sticks, available from welding supply stores, to be sure the cylinder head is heated to the proper temperature.

To avoid burns, wear insulated gloves when handling the heated cylinder head.

Be careful not to damage the cylinder head.

Support the cylinder head and drive out the old guides from the combustion chamber side of the head.

TOOL:

Valve guide driver
5.5 mm (IN/EX)

07742-0010100

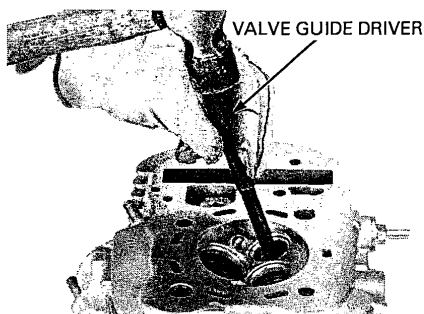

Adjust the valve guide driver to the valve guide height.

TOOL:

Valve guide driver

07743-0020000
Not available in
U.S.A.

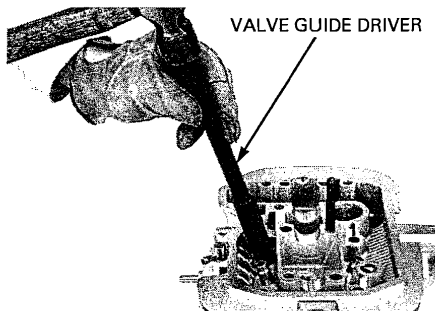

NEW

VALVE GUIDE PROJECTION ABOVE CYLINDER HEAD:

IN: 18.7 – 18.9 mm (0.736 – 0.744 in)
EX: 17.2 – 17.4 mm (0.68 – 0.69 in)

Drive new guides in from the camshaft side of the cylinder head to the valve guide height while the cylinder head is still heated.

Let the cylinder head cool to room temperature, then ream new valve guides.

TOOLS:

Valve guide reamer
5.510 mm (IN/EX)

07984-2000001 or
07984-200000D
(U.S.A. only)

NOTE:

- Take care not to tilt or lean the reamer in the guide while reaming. Otherwise, the valves maybe installed slanted, causing oil leakage from the stem seal and improper valve seat contact. This may prevent valve seat refacing.
- Insert the reamer from the combustion chamber side of the head and always rotate the reamer clockwise.

Clean the cylinder head thoroughly to remove any metal particles after reaming.

Reface the valve seat (page 9-20).

VALVE GUIDE REAMER

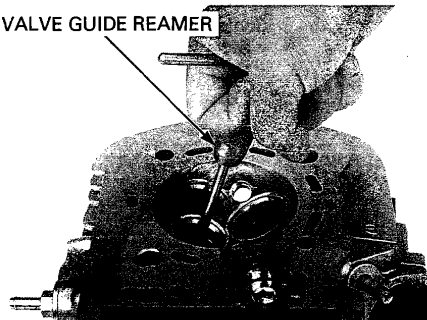

VALVE SEAT INSPECTION/REFACING

INSPECTION

Clean all intake and exhaust valves thoroughly to remove carbon deposits.

Apply a thin coat of Prussian Blue to each valve face.

Tap the valve against the valve seat several times using a hand-lapping tool without rotating valve to make a clear pattern.

HAND-LAPPING TOOL

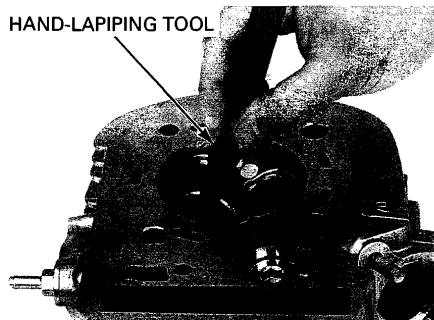

Remove the valve and inspect the valve seat face.

NOTE:

The valve cannot be ground. If the valve face is burned or badly worn or if it contacts the seat unevenly, replace the valve.

Inspect the valve seat face for:

- Damaged face:
– Replace the valve and reface the valve seat.
- Uneven seat width:
– Replace the valve and reface the valve seat.

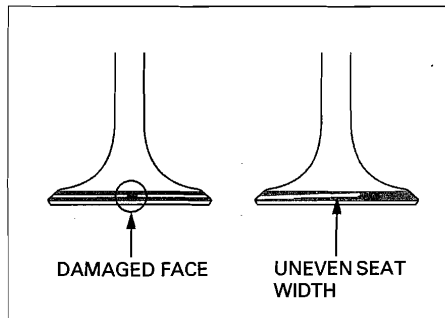

CYLINDER HEAD/VALVE

- Contact area (too high or too low area):
 - Reface the valve seat.

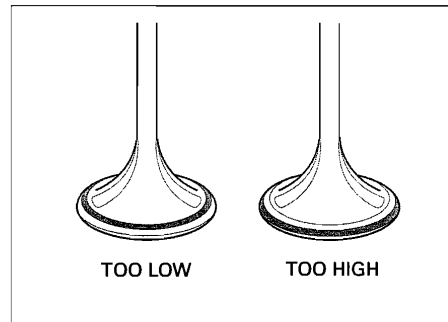

Inspect the width of the valve seat.

The valve seat contact should be within the specified width and even all around the circumference.

STANDARD: 0.90 – 1.10 mm (0.035 – 0.043 in)
SERVICE LIMIT: 1.5 mm (0.06 in)

If the valve seat width is not within specification, reface the valve seat.

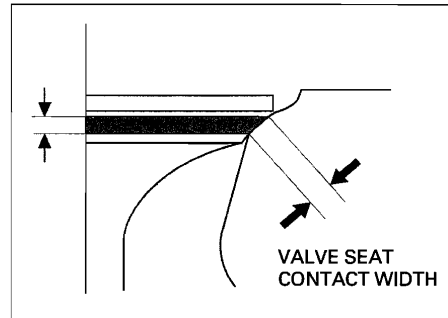

VALVE SEAT REFACING

NOTE:

- Follow the refacing manufacturer's operating instructions.
- Reface the valve seat whenever the valve guide has been replaced.
- Be careful not to grind the seat more than necessary.

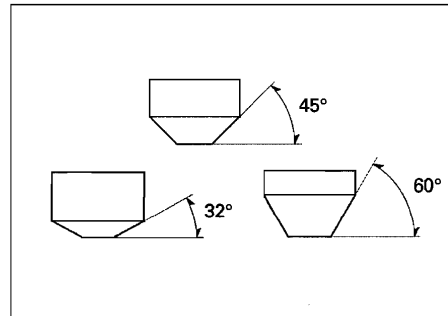

If the contact area is too high on the valve, the seat must be lowered using a 32° flat cutter.

If the contact area is too low on the valve, the seat must be raised using a 60° interior cutter.

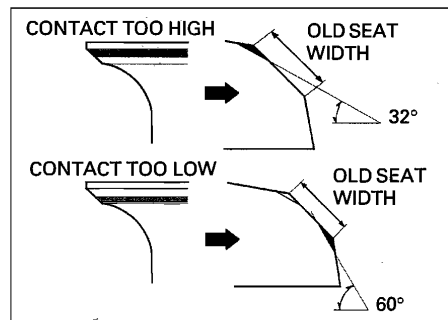

Using a 45° cutter, remove any roughness or irregularities from the seat.

TOOLS:

- Seat cutter, 27.5 mm (IN) 07780-0010200
- Seat cutter, 35 mm (EX) 07780-0010400
- Cutter holder, 5.5 mm 07781-0010101

or equivalent commercially available in U.S.A.

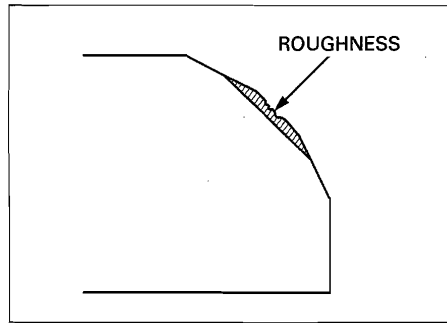

Using a 32° cutter, remove the top 1/4 of the existing valve seat material.

TOOLS:

- Flat cutter, 28 mm (IN) 07780-0012100
- Flat cutter, 35 mm (EX) 07780-0012300
- Cutter holder, 5.5 mm 07781-0010101

or equivalent commercially available in U.S.A.

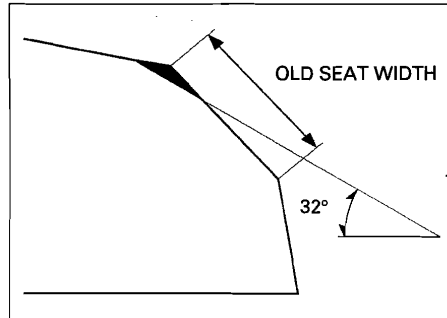

Using a 60° cutter, remove the bottom 1/4 of the old seat.

TOOLS:

- Interior cutter, 30 mm (IN) 07780-0014000
- Interior cutter, 37.5 mm (EX) 07780-0014100
- Cutter holder, 5.5 mm 07781-0010101

or equivalent commercially available in U.S.A.

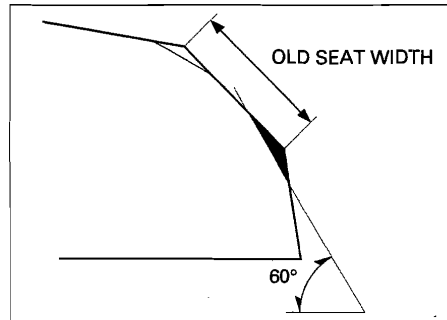

Using a 45° seat cutter, cut the seat to the proper width. Make sure that all pitting and irregularities are removed.

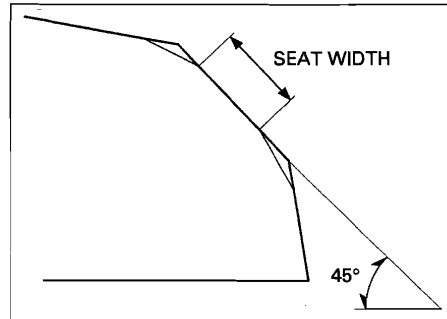

CYLINDER HEAD/VALVE

After cutting the seat, apply lapping compound to the valve face, and lap the valve using light pressure.

- Excessive lapping pressure may deform or damage the seat.
- Change the angle of lapping tool frequently to prevent uneven seat wear.
- Lapping compound can cause damage if it enters between the valve stem and guide.

After lapping, wash any residual compound off the cylinder head and valve.

Recheck the seat contact after lapping.

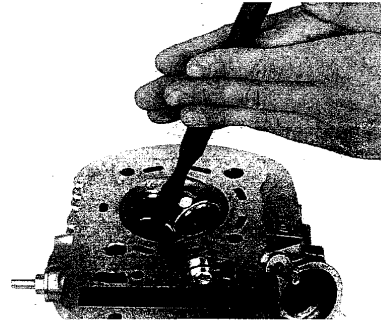

CYLINDER HEAD ASSEMBLY

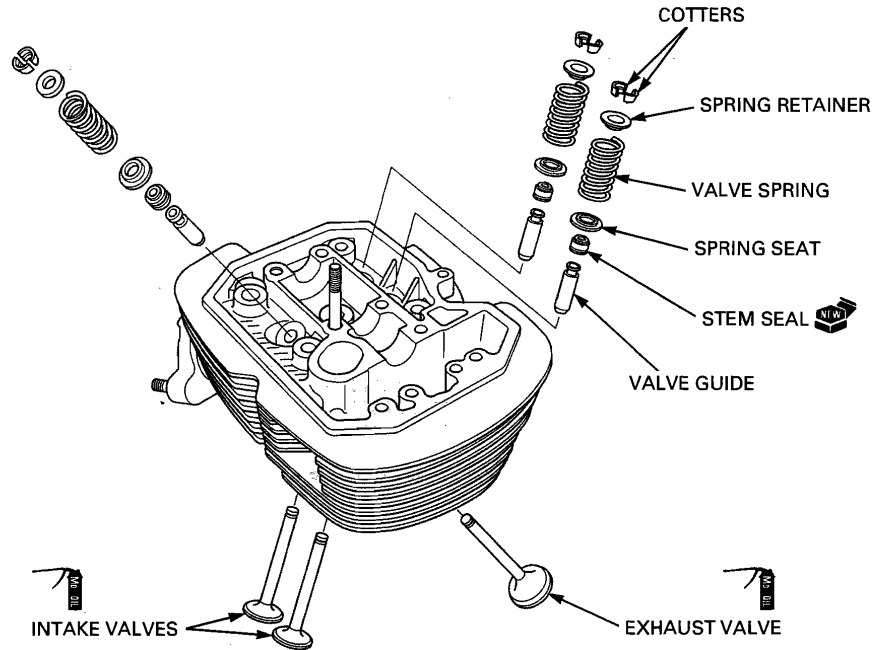

Blow out all of the oil passages in the cylinder head with compressed air.

Exhaust stem seal has stopper rings.

Install the spring seat and new stem seal.

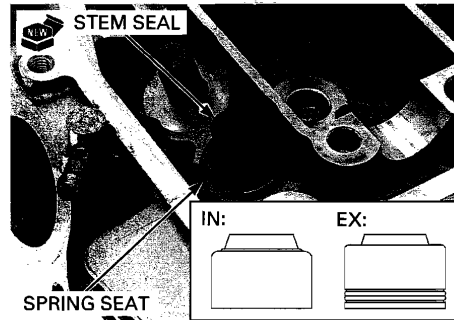

Lubricate the molybdenum disulfide oil to the valve guide sliding surface of the valve stem.

Install the valve into the valve guide.

NOTE:

- Exhaust valve spring has a larger O.D. than intake valve spring.
- To avoid damage to the stem seal, turn the valve slowly when installing the valve.

Install the valve spring with tightly wound coils facing the combustion chamber.

Install the spring retainer.

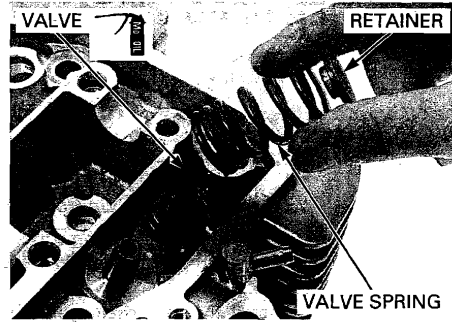

Grease the cotters to ease installation.

Install the cotters using a special tool.

TOOL:

Valve spring compressor 07757-0010000

NOTE:

Compressing the valve springs more than necessary will cause loss of valve spring tension.

SPRING COMPRESSOR

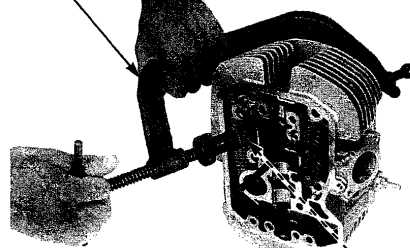

Support the cylinder head so the valve heads will not contact anything and possibly get damaged.

Tap the valve stems gently with two plastic hammers to seat the cotters firmly as shown.

Install the spark plugs (page 4-10).

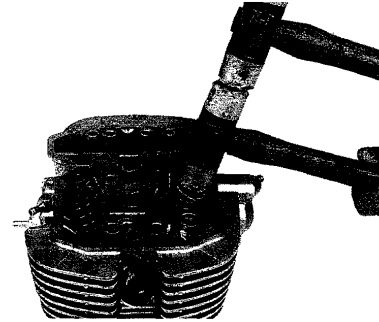

CYLINDER HEAD INSTALLATION

NOTE:

- The front cylinder head uses the same service procedure as the rear cylinder head.
- Be careful not to damage the mating surfaces when cleaning the cylinder head mating surface.
- When cleaning the cylinder head mating surface, place the shop towel over the cylinder opening to prevent dust or dirt from entering the engine.

Clean the gasket mating surfaces of the cylinder and cylinder head thoroughly, being careful not to damage them.

Install the cam chain guide by aligning the guide end with the groove in the crankcase and the bosses with the groove in the cylinder.

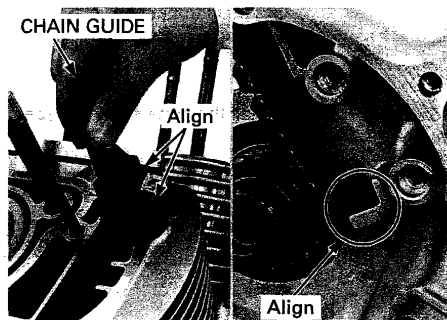

Install the dowel pins and a new gasket.

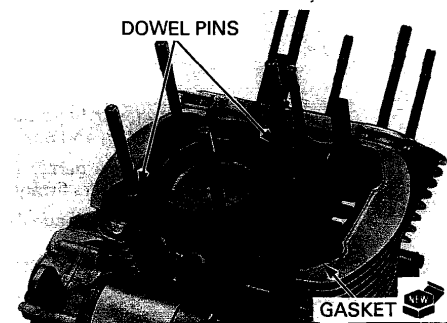

The cylinder heads are identified by marks on their oil pockets.

- "F": Front cylinder head
- "R": Rear cylinder head

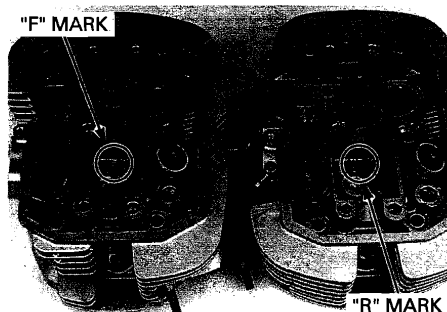

Install the cylinder head to the cylinder.
 Apply engine oil to the cylinder head each bolts and nuts threads and seating surfaces.
 Install and tighten the cylinder head 8 mm bolts, 10 mm nuts and washer to the specified torque.

TORQUE:
 10 mm nut: 47 N-m (4.8 kgf-m, 35 lbf-ft)
 8 mm bolt: 23 N-m (2.3 kgf-m, 17 lbf-ft)

Install and tighten the 6 mm bolt securely.

- NOTE:**
- Tighten all to hand-tight, then torque the larger fasteners before tightening the smaller fasteners.
 - Tighten the bolts and nuts in a crisscross pattern in several steps.

Install the cam chain tensioner, aligning its end with the groove in the crankcase.

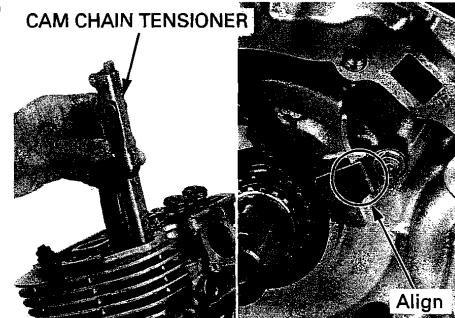
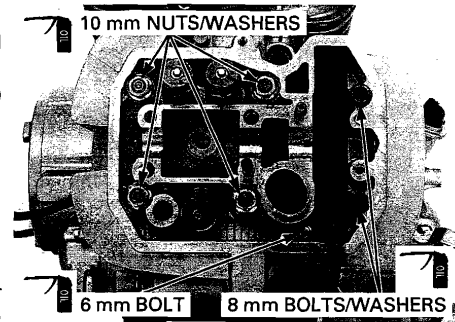

- Tighten the tensioner bolts as follow:
1. Temporarily install the tensioner bolts with new sealing-washers.
 2. Tighten the cylinder head side cam chain tensioner bolt to the specified torque.
TORQUE: 10 N-m (1.0 kgf-m, 7 lbf-ft)
 3. Tighten the cylinder side cam chain tensioner bolt to the specified torque.
TORQUE: 10 N-m (1.0 kgf-m, 7 lbf-ft)

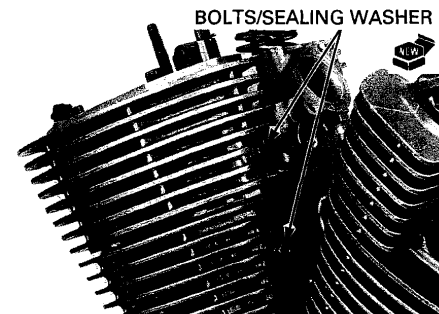

Install a new O-ring to the water hose joint.

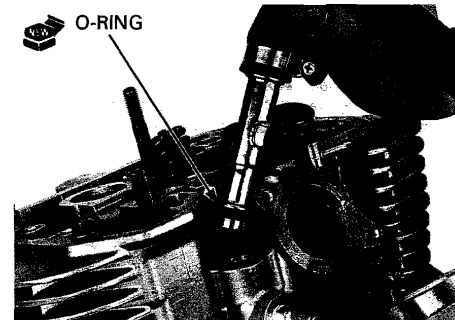

CYLINDER HEAD/VALVE

Install the water hose joint by aligning the bolt holes in the stopper plate and cylinder head. Install and tighten the bolt securely.

Rear cylinder head only:

Connect the vacuum hose.

Install the engine into the frame (page 8-7).

Install the following:

- Camshaft (page 9-26)
- Cylinder head cover (page 9-31)
- Intake manifold (page 6-23)

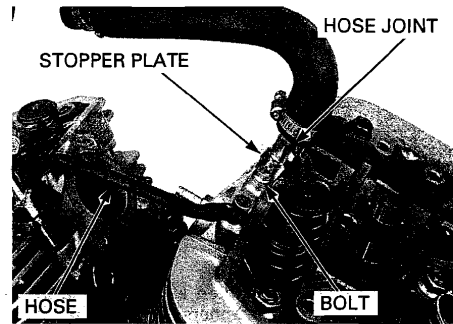

CAMSHAFT INSTALLATION

CAMSHAFT HOLDER ASSEMBLY

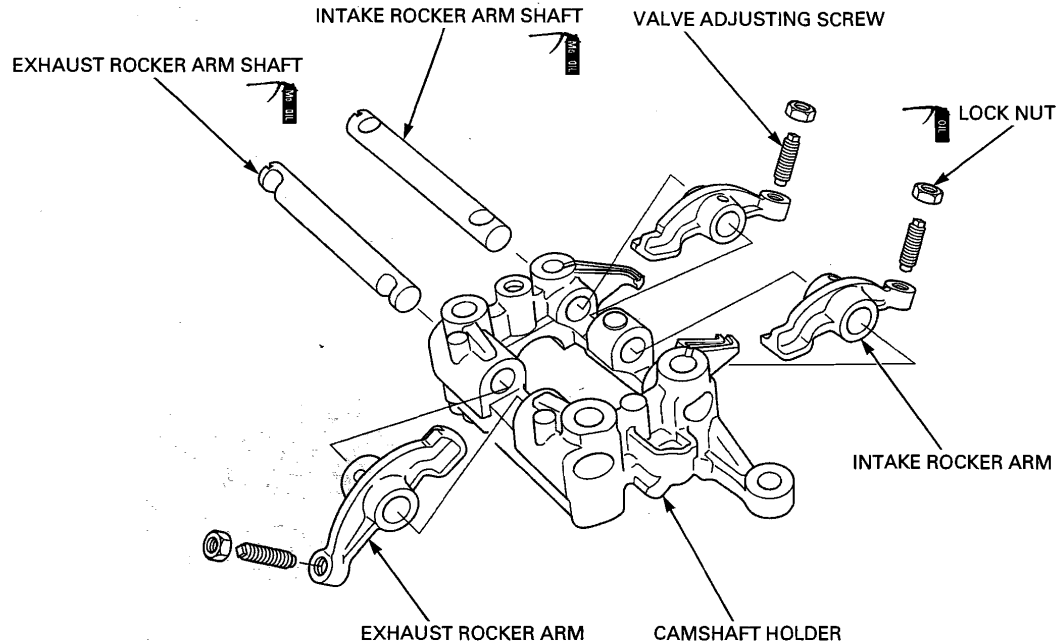

When disassembling the valve adjusting lock nut and adjusting screw.

Apply engine oil to the valve adjusting screw lock nut threads and seating surface. Install the valve adjusting screw and lock nut.

ADJUSTING SCREW

LOCK NUT

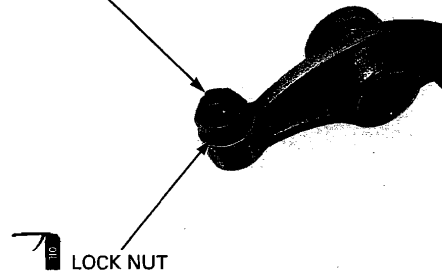

NOTE:

- The exhaust rocker arm has larger slipper face than the intake rocker arm.
- The intake rocker arm shaft has two holes on each end.
- The exhaust rocker arm shaft has two grooves on each end.

Apply molybdenum disulfide oil solution to the rocker arm shaft outer surface.
Install the rocker arms and shafts.

ROCKER ARMS

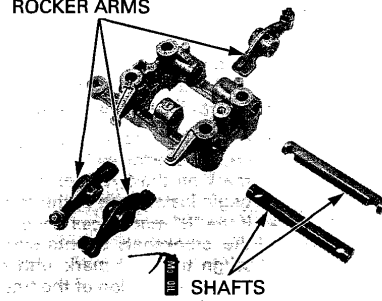

Align the intake rocker arm shaft holes with the camshaft holder holes.
Align the exhaust rocker arm shaft grooves with the camshaft holder holes.

HOLES

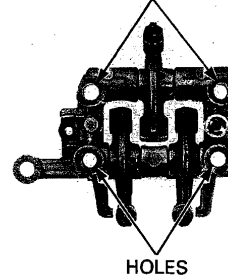

CAMSHAFT TIMING PROCEDURE

NOTE:

- The camshafts are identified by the stamped marks:
 - "F": Front cylinder camshaft
 - "R": Rear cylinder camshaft
- If both (front and rear) camshafts are removed, install the front cylinder camshaft first, then install the rear cylinder camshaft.
- If the rear cylinder head is not serviced, remove the rear cylinder head cover to check the camshaft position.
- If the front cylinder head is not serviced, remove the front cylinder head cover to check the camshaft position.

"R" MARK

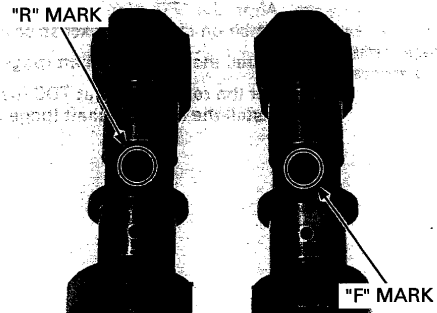

FRONT CYLINDER TDC SETTING

If the rear cylinder has not been serviced, begin here.

Remove the rear cylinder head cover (page 9-7) and check the rear cylinder camshaft position as follows:

Turn the crankshaft counterclockwise and align the "RT" mark on the flywheel with the index notch on the left crankcase cover, then check the identification mark "R" on the rear camshaft.

- If the "R" mark faces up, turn the crankshaft counterclockwise 1-1/7 (412°) turn (align the "FT" mark on the flywheel with the index notch) and begin installation of the front camshaft.
- If the "R" mark faces down (cannot be seen), turn the crankshaft counterclockwise 1/7 (52°) turn (align the "FT" mark with the index notch) and begin installation of the front camshaft.

Install the front camshaft (page 9-29).

INDEX NOTCH

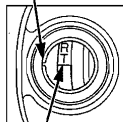

"RT" MARK

"R" MARK

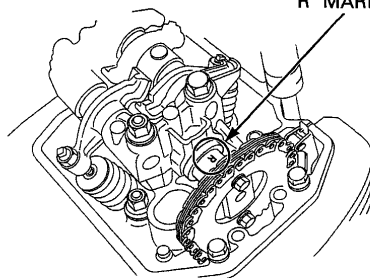

BOTH CYLINDER TDC SETTING

If both camshafts have been serviced, begin installation of the front camshaft.

Align the "FT" mark on the flywheel with the index notch on the left crankcase cover.

Install the front camshaft (page 9-29).

Set the rear cylinder at TDC (page 9-29).

Install the rear camshaft (page 9-29).

INDEX NOTCH

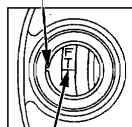

"FT" MARK

REAR CYLINDER TDC SETTING

If the front cylinder has not been serviced, begin here.

Remove the front cylinder head cover (page 9-6) and check the front cylinder camshaft position as follows:

Turn the crankshaft counterclockwise and align the "FT" mark on the flywheel with the index notch on the left crankcase cover, then check the identification mark "F" on the front camshaft.

- If the "F" mark faces up, turn the crankshaft counterclockwise 6/7 (308°) turn (align the "RT" mark on the flywheel with the index notch) and begin installation of the rear camshaft.
- If the "F" mark faces down (cannot be seen), turn the crankshaft clockwise 1-6/7 (668°) turn (align the "RT" mark with the index notch) and begin installation of the rear camshaft.

Install the rear camshaft using the following procedure.

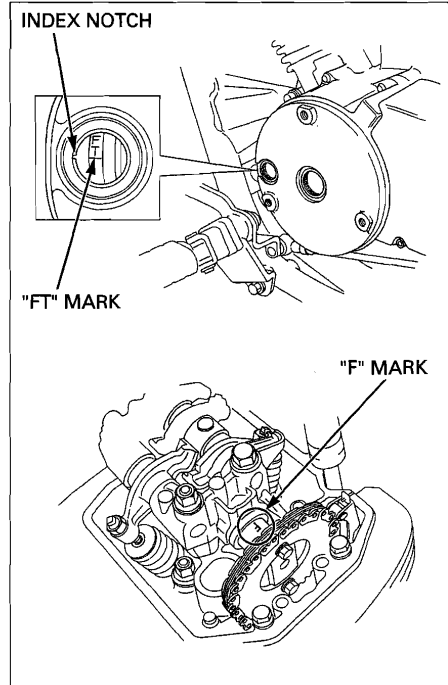

CAMSHAFT INSTALLATION

NOTE:

Make sure to follow the CAMSHAFT TIMING PROCEDURE (page 9-27) before installing the camshaft.

The front and rear camshafts are installed with the same procedure.

Lubricate the camshaft lobes and journal surfaces with molybdenum disulfide oil.

Install the camshaft with the camshaft identification mark (R: rear camshaft, F: front camshaft) facing up.

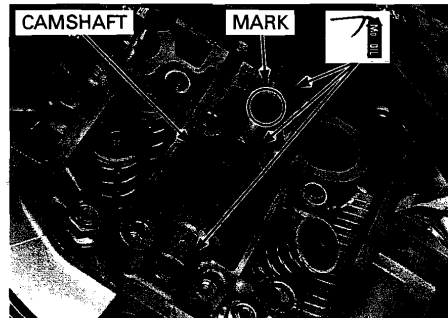

CYLINDER HEAD/VALVE

Lubricate each rocker arm slipper surface with molybdenum disulfide oil.

NOTE:

Before camshaft holder installation, loosen the valve adjusting screw and lock nut fully.

Install the camshaft holder assembly.

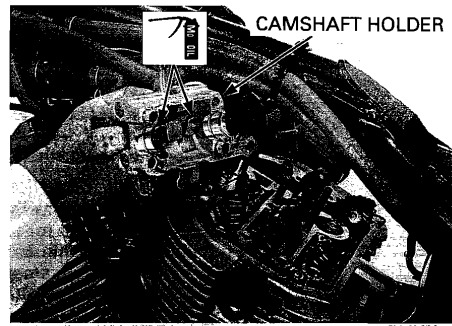

Install the camshaft holder bolts and nuts. Tighten the bolts and nuts to the specified torque in a crisscross pattern in several steps.

TORQUE:

Camshaft holder bolt: 23 N·m (2.3 kgf·m, 17 lbf·ft)

Camshaft holder nut: 23 N·m (2.3 kgf·m, 17 lbf·ft)

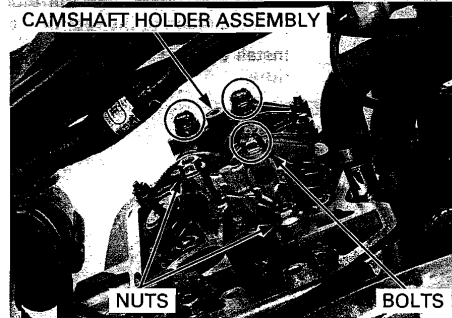

Install the cam sprocket to the cam chain with the "IN" mark facing inside.

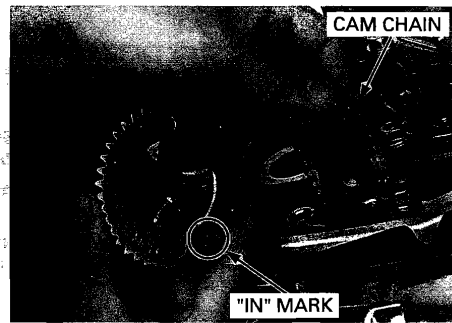

Install the cam sprocket on the camshaft flange and check that the timing marks align with the upper surface of the cylinder head.

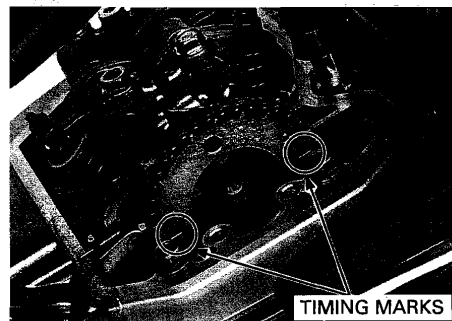

Be careful not to let the cam sprocket bolts fall into the crankcase.

Clean and apply a locking agent to the cam sprocket bolt threads.

Align the cam sprocket bolt holes in the cam sprocket and camshaft.
Temporarily install the cam sprocket bolt.
Turn the crankshaft counterclockwise 360° and tighten the other sprocket bolt to the specified torque.

TORQUE: 23 N·m (2.3 kgf·m, 17 lbf·ft)

Turn the crankshaft counterclockwise 360° and tighten the other sprocket bolt to the specified torque.

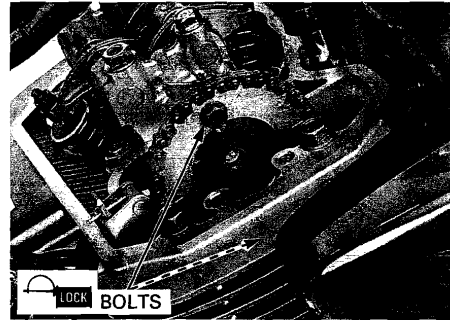

Remove an O.D. 2 mm pin while holding cam chain tensioner wedge A and pushing down the wedge B.

NOTE:

- Be careful not to let an O.D. 2 mm pin fall into the crankcase.
- Do not forget to remove an O.D. 2 mm pin before installing the cylinder head cover.

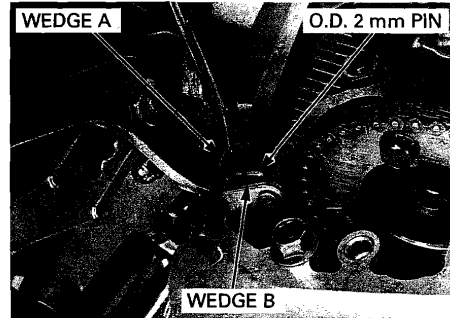

Fill the oil pockets in the cylinder head with engine oil.
Adjust the valve clearance (page 4-10).

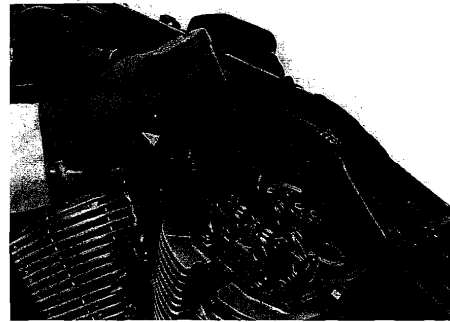

CYLINDER HEAD COVER INSTALLATION

Clean the gasket groove and cylinder head mating surface of the cylinder head cover.

Check the gasket is in good condition, replace it if necessary.

Apply Pro Honda Hondabond HT or equivalent to the gasket groove of the cylinder head cover.

Install the gasket into the groove.

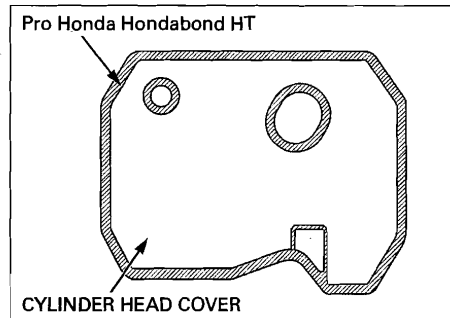

CYLINDER HEAD/VALVE

FRONT

Clean the cylinder head cover mating surface of the cylinder head.

Install the front cylinder head cover on the front cylinder head.

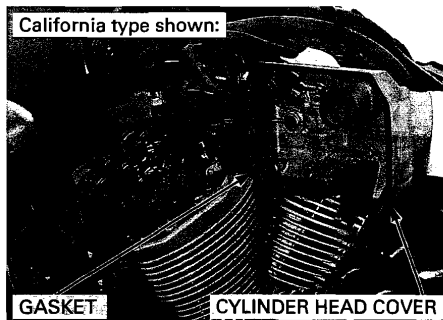

Check the condition of the rubber seals, replace them if necessary.

Install the rubber seals onto the cylinder head cover in the direction as shown.

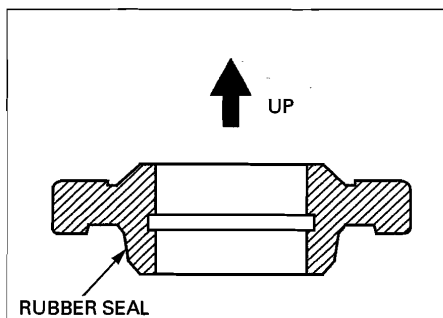

Install the washers.
Install and tighten the cylinder head cover bolts to the specified torque.

TORQUE: 10 N·m (1.0 kgf·m, 7 lbf·ft)

Connect the air supply hose.



Install the front left over head cover and tighten the socket bolts to the specified torque.

TORQUE: 10 N·m (1.0 kgf·m, 7 lbf·ft)

Connect the spark plug cap.

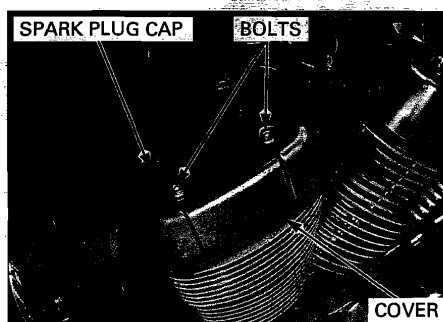

Install the front right over head cover and tighten the socket bolts to the specified torque.

TORQUE: 10 N·m (1.0 kgf·m, 7 lbf·ft)

Connect the spark plug cap.

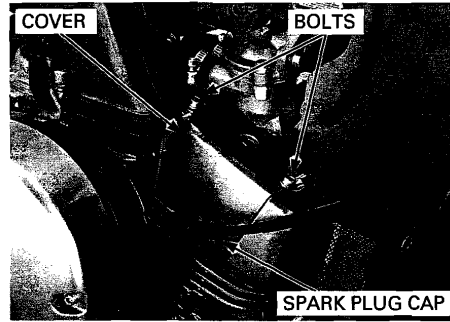

REAR

Clean the cylinder head cover mating surface of the cylinder head.

Install the rear cylinder head cover on the rear cylinder head.

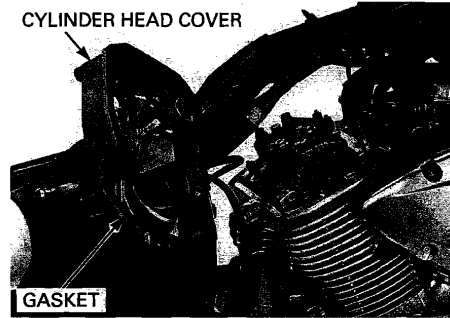

Install the rubber seals (page 9-32).
Install the washers.
Install and tighten the cylinder head cover bolts to the specified torque.

TORQUE: 10 N·m (1.0 kgf·m, 7 lbf·ft)

Connect the crankcase breather hose.

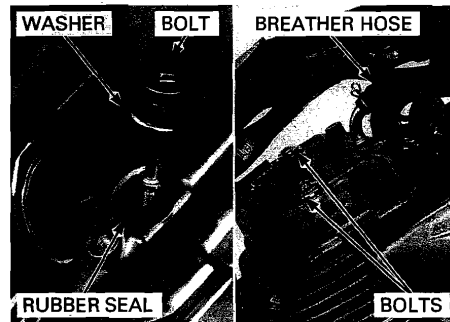

Install the rear left over head cover and tighten the socket bolts to the specified torque.

TORQUE: 10 N·m (1.0 kgf·m, 7 lbf·ft)

Install the rear PAIR check valve and cover.
Install and tighten the rear PAIR check valve cover bolt to the specified torque.

TORQUE: 7 N·m (0.7 kgf·m, 5.2 lbf·ft)

Connect the spark plug cap.

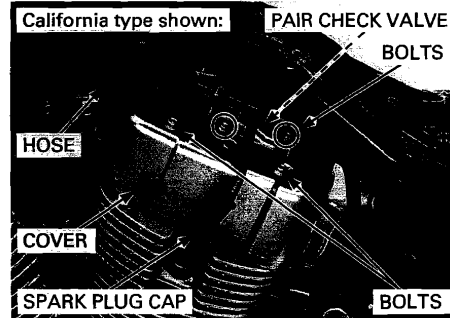

CYLINDER HEAD/VALVE

Install the rear right over head cover and tighten the socket bolts to the specified torque.

TORQUE: 10 N·m (1.0 kgf·m, 7 lbf·ft)

Connect the spark plug cap.

Install the fuel tank (page 3-4).

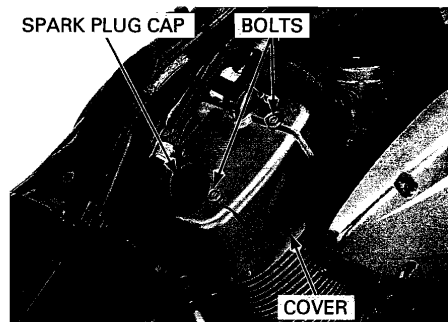

10. CYLINDER/PISTON

COMPONENT LOCATION 10-2
SERVICE INFORMATION 10-3
TROUBLESHOOTING 10-3

CYLINDER/PISTON REMOVAL 10-4
CYLINDER/PISTON INSTALLATION 10-9

CYLINDER/PISTON
COMPONENT LOCATION

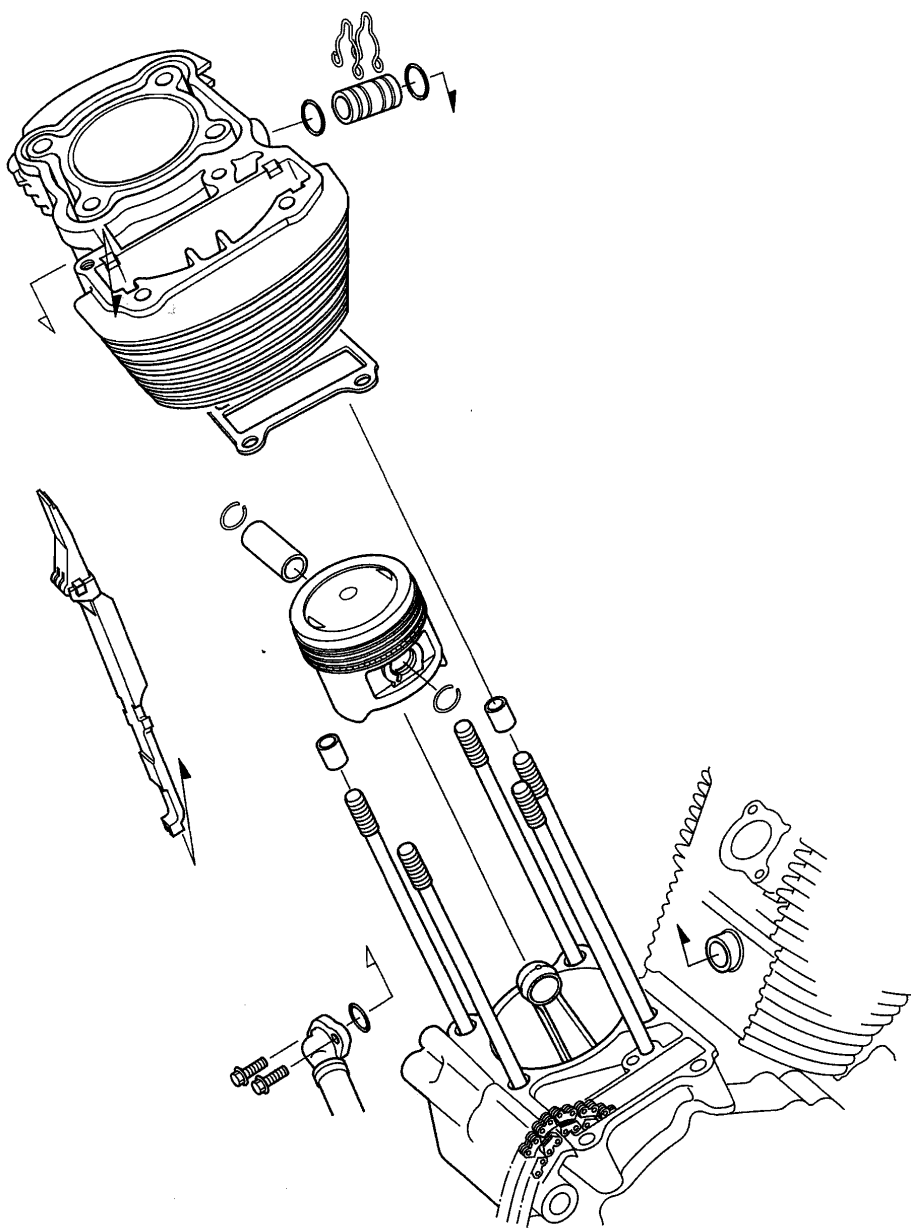

SERVICE INFORMATION

GENERAL

- This section covers service of the piston and cylinder. To service these parts, the engine must be removed from the frame.
- Take care not to damage the cylinder walls and pistons.
- Be careful not to damage the mating surfaces when removing the cylinder. Do not strike the cylinder too hard during removal.
- When disassembling, mark and store the disassembled parts to ensure that they are reinstalled in their original locations.
- Clean all disassembled parts with cleaning solvent and dry them by blowing them off with compressed air before inspection.
- Camshaft and rocker arm lubricating oil is fed through oil passages in the cylinder. Clean the oil passages before installing the cylinder.

SPECIFICATIONS

ITEM		STANDARD	SERVICE LIMIT	
Cylinder	I.D.	79.000 – 79.015 (3.1102 – 3.1108)	79.10 (3.114)	
	Out-of-round	–	0.06 (0.002)	
	Taper	–	0.06 (0.002)	
	Warpage	–	0.10 (0.004)	
Piston, piston pin, piston rings	Piston O.D. at 17 mm (0.7 in) from the bottom	78.97 – 78.99 (3.109 – 3.110)	78.90 (3.106)	
	Piston pin bore I.D.	18.002 – 18.008 (0.7087 – 0.7090)	18.05 (0.711)	
	Piston pin O.D.	17.994 – 18.000 (0.7084 – 0.7087)	17.98 (0.708)	
	Piston-to-piston pin clearance	0.002 – 0.014 (0.0001 – 0.0006)	0.04 (0.002)	
	Piston ring end gap	Top	0.15 – 0.25 (0.006 – 0.010)	0.4 (0.02)
		Second	0.25 – 0.40 (0.010 – 0.016)	0.6 (0.02)
		Oil (side rail)	0.20 – 0.80 (0.008 – 0.031)	1.0 (0.04)
	Piston ring-to-ring groove clearance	Top	0.025 – 0.055 (0.0010 – 0.0022)	0.08 (0.003)
Second		0.015 – 0.045 (0.0006 – 0.0018)	0.07 (0.003)	
Cylinder-to-piston clearance		0.010 – 0.045 (0.0004 – 0.0018)	0.10 (0.004)	
Connecting rod small end I.D.		18.016 – 18.034 (0.7093 – 0.7100)	18.07 (0.711)	
Connecting rod-to-piston pin clearance		0.016 – 0.040 (0.0006 – 0.0016)	0.06 (0.002)	

Unit: mm (in)

TORQUE VALUES

Cylinder stud bolt (8 mm)	See page 10-8
Cylinder stud bolt (10 mm)	See page 10-8
Cylinder stud bolt (12 mm)	See page 10-8

TROUBLESHOOTING

Compression too low, hard starting or poor performance at low speed

- Leaking cylinder head gasket
- Worn, stuck or broken piston ring
- Worn or damaged cylinder and piston

Compression too high, overheating or knocking

- Excessive carbon built-up on piston head or combustion chamber

Excessive smoke

- Worn cylinder, piston or piston rings
- Improper installation of piston rings
- Scored or scratched piston or cylinder wall

Abnormal noise

- Worn piston pin or piston pin bore
- Worn cylinder, piston or piston rings
- Worn connecting rod small end

CYLINDER/PISTON REMOVAL

CYLINDER REMOVAL

NOTE:

The front cylinder uses the same service procedure as the rear cylinder.

Remove the cylinder head (page 9-14).

Front cylinder only: Remove the bolts, water hose joint and O-ring.

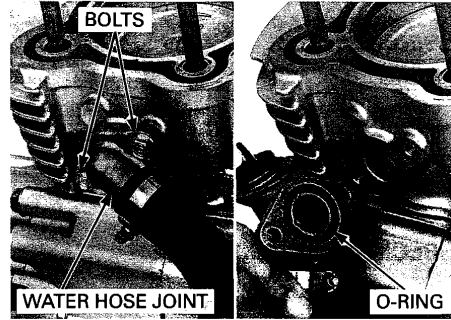

Remove the retaining clips.

Slide the cylinder joint collar toward either the front or rear cylinder.

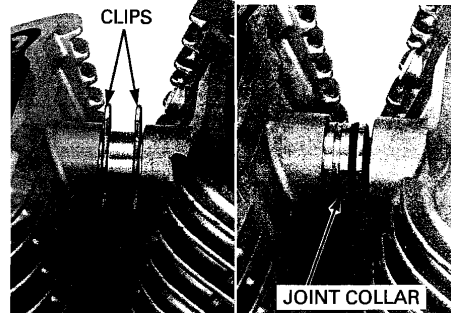

Lift the cylinder and remove it, being careful not to damage the piston with the stud bolts.

NOTE:

- Attach a piece of wire to the cam chain to prevent it from falling into the crankcase.
- Do not strike the cylinder too hard and do not damage the mating surface with a screwdriver.

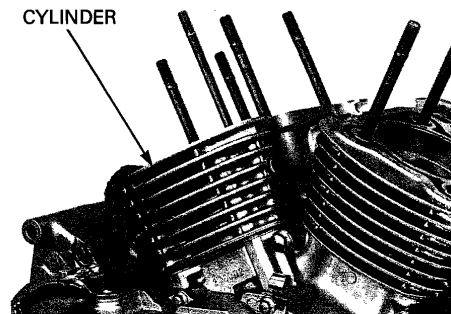

Remove the joint collar from the cylinder.

Remove the O-rings.

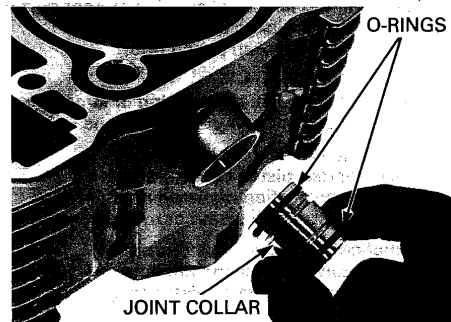

Remove the gasket and dowel pins.

Be careful not to damage the gasket surface.

Clean off any gasket material from the cylinder mating surface.

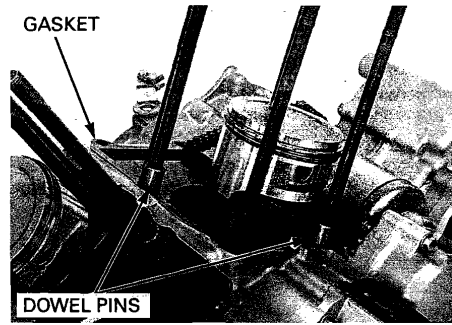

PISTON REMOVAL

Place a clean shop towel over the crankcase to prevent the piston pin clips from falling into the crankcase.

Remove the piston pin clips with pliers. Push the piston pin out of the piston and connecting rod, and remove the piston.

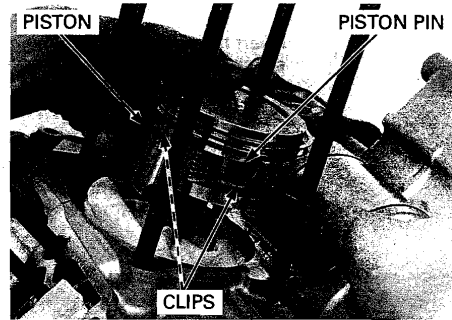

Do not damage the piston ring by spreading the ends too far.

Spread each piston ring and remove it by lifting up a point opposite the gap.

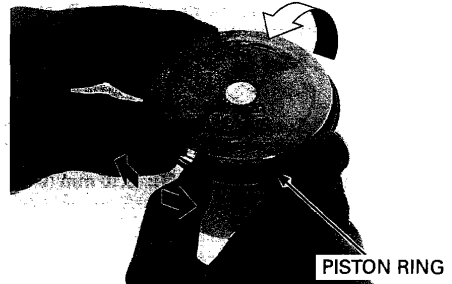

Never use a wire brush; it will scratch the groove.

Clean carbon deposits from the ring grooves with a used piston ring that will be discarded.



CYLINDER/PISTON

INSPECTION

PISTON/PISTON RING

Always replace the piston rings as a set.

Inspect the piston rings for smooth movement by rotating them. The rings should be able to move in their grooves without catching.

Push the ring until the outer surface of the piston ring is nearly flush with the piston and measure the ring-to-ring groove clearance.

SERVICE LIMITS:

Top: 0.08 mm (0.003 in)

Second: 0.07 mm (0.003 in)



Insert the piston ring into the bottom of the cylinder squarely using the piston crown. Measure the piston ring end gap.

SERVICE LIMITS:

Top: 0.4 mm (0.02 in)

Second: 0.6 mm (0.02 in)

Oil (side rail): 1.0 mm (0.04 in)

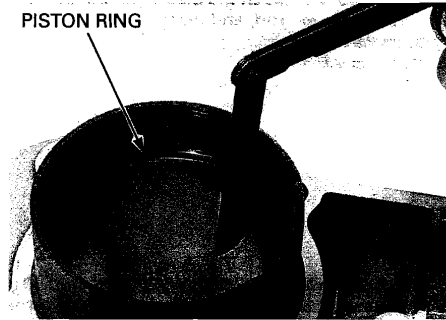

Measure the piston O.D. at a point 17 mm (0.7 in) from the bottom and 90° to the piston pin hole.

SERVICE LIMIT: 78.90 mm (3.106 in)

Compare this measurement against the maximum cylinder I.D. measurement and calculate the cylinder-to-piston clearance (page 10-7).

SERVICE LIMIT: 0.10 mm (0.004 in)

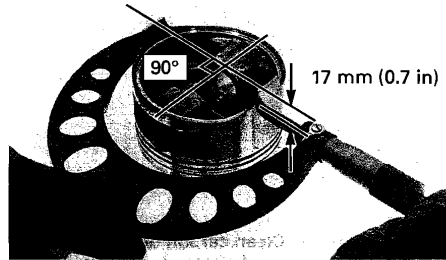

Measure the piston pin O.D. at three points.

SERVICE LIMIT: 17.98 mm (0.708 in)

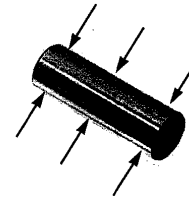

Measure the piston pin bore I.D.

SERVICE LIMIT: 18.05 mm (0.711 in)

Calculate the piston-to-piston pin clearance.

SERVICE LIMIT: 0.04 mm (0.002 in)

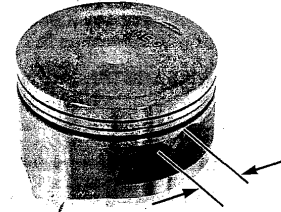

CONNECTING ROD

Measure the connecting rod small end I.D.

SERVICE LIMIT: 18.07 mm (0.711 in)

Calculate the connecting rod-to-piston pin clearance.

SERVICE LIMIT: 0.06 mm (0.002 in)

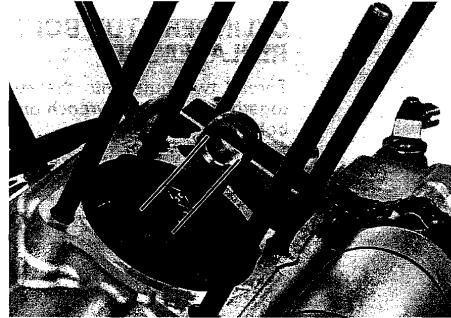

CYLINDER

Check the top of the cylinder for warpage with a straight edge and feeler gauge across the stud holes.

SERVICE LIMIT: 0.10 mm (0.004 in)

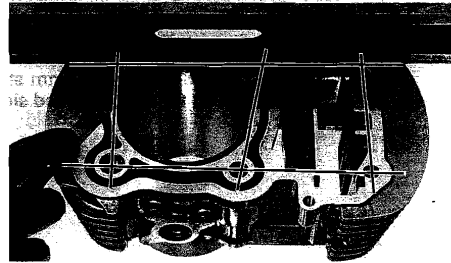

Check the cylinder wall for scratches or wear. Measure the cylinder I.D. at three levels on the X and Y axes. Take the maximum reading to determine the cylinder wear.

SERVICE LIMIT: 79.10 mm (3.114 in)

Calculate the cylinder-to-piston clearance.

SERVICE LIMIT: 0.10 mm (0.004 in)

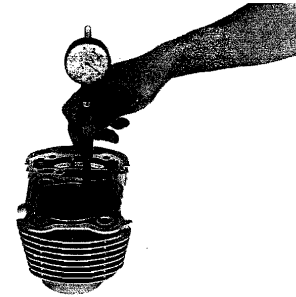

CYLINDER/PISTON

Calculate the cylinder taper and out-of-round at three levels on the X and Y axes. Take the maximum reading to determine the taper and out-of-round.

SERVICE LIMITS:

Taper: 0.06 mm (0.002 in)

Out-of-round: 0.06 mm (0.002 in)

The cylinder must be rebored and an oversize piston fitted if the service limits are exceeded.

The following oversize pistons are available:

0.25 mm (0.010 in)

0.50 mm (0.020 in)

The piston to cylinder clearance for the oversize piston must be: 0.010 – 0.045 mm (0.0004 – 0.0018 in).

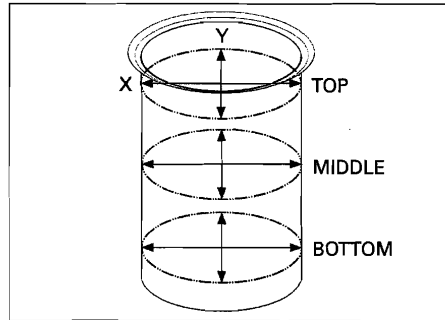

CYLINDER STUD BOLT REPLACEMENT

Thread two nuts onto the stud and tighten them together, and use a wrench on them to turn the stud bolt out.

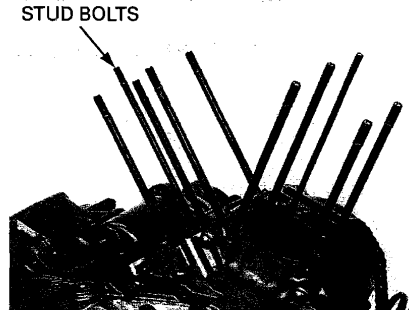

Apply engine oil to the lower threads of a new stud bolt and install it.

NOTE:

Install the 8 mm and 10 mm stud bolts with its tab side facing the cylinder head side.

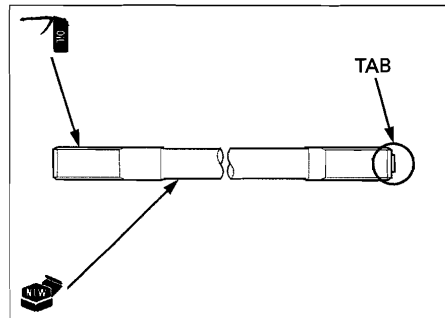

Be sure to verify the stud height from the crankcase surface.

Adjust the height if necessary.

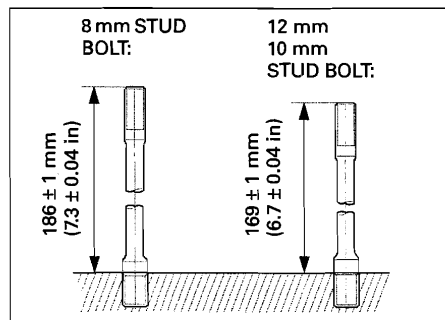

CYLINDER/PISTON INSTALLATION

PISTON RING INSTALLATION

Apply engine oil to the piston and piston ring outer surface.

Be careful not to damage the piston and rings.

Carefully install the piston rings into the piston ring grooves with the markings facing up.

NOTE:

- Do not confuse the top and second rings.
- To install the oil ring, install the spacer first, then install the side rails.

Stagger the piston ring end gaps 120° apart from each other.

Stagger the side rail end gaps as shown.

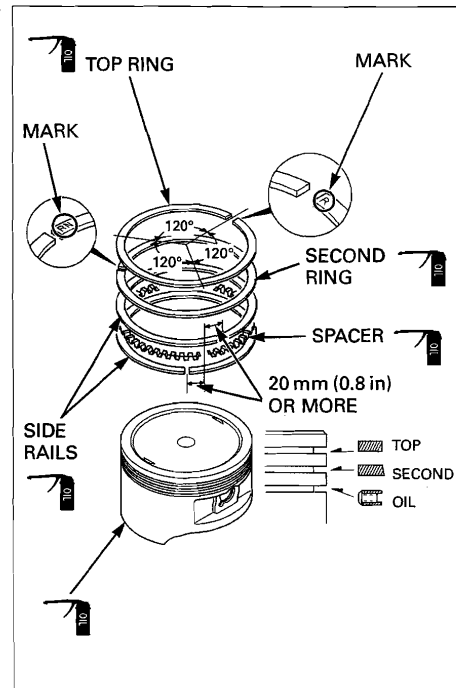

PISTON INSTALLATION

Apply molybdenum disulfide oil to the connecting rod small end inner surface.

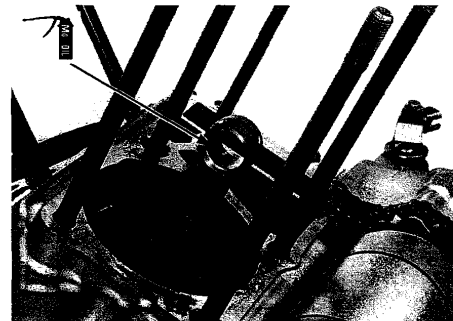

Place a clean shop towel over the crankcase to prevent the clip from falling into the crankcase.

Apply engine oil to the piston pin outer surface.

Install the piston.

Install the piston pin through the piston and connecting rod.

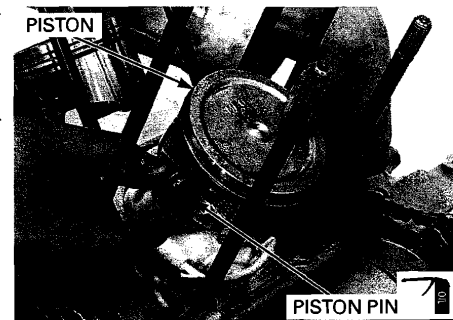

CYLINDER/PISTON

Install new piston pin clips into the grooves in the piston pin hole.

NOTE:

- Make sure the piston pin clips are seated securely.
- Do not align the clip end gap with the piston cut-out.

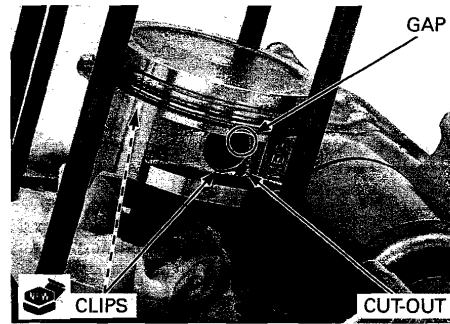

CYLINDER INSTALLATION

The front cylinder uses the same service procedure as the rear cylinder.

Clean the gasket surfaces of the cylinder and crankcase thoroughly, being careful not to damage them.

Install new O-rings to the joint collar.
Install the joint collar to the cylinder.

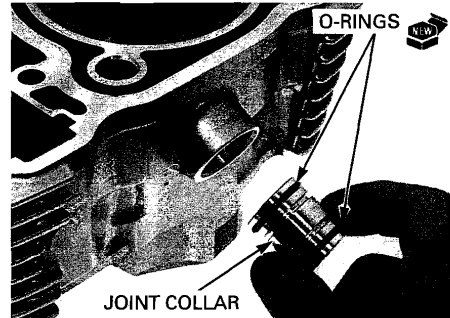

Install the dowel pins and a new gasket.

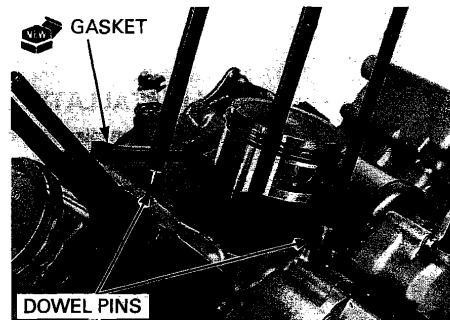

Be careful not to damage the piston rings and cylinder wall.

Apply engine oil to the cylinder wall, piston outer surface and piston rings.

Route the cam chain through the cylinder and install the cylinder over the piston while compressing the piston rings with your fingers.

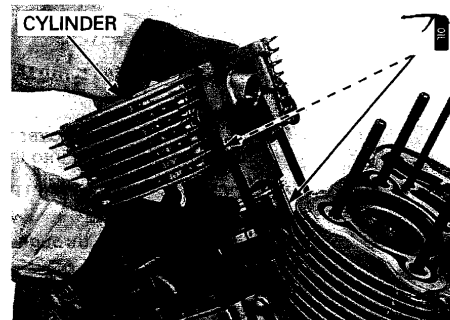

Slide the joint collar into the hole in the cylinder and connect it.
Install the retaining clips into the joint collar grooves.

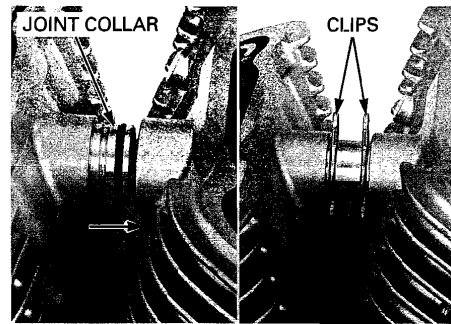

Front cylinder only: Install a new O-ring into the water hose joint groove.
Install and tighten the hose joint bolts securely.
Install the cylinder head (page 9-24).

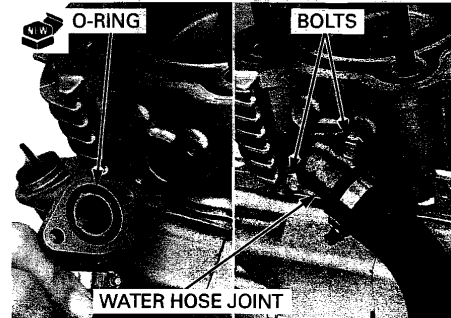

11. CLUTCH/GEARSHIFT LINKAGE

COMPONENT LOCATION	11-2	PRIMARY DRIVE GEAR.....	11-12
SERVICE INFORMATION	11-3	GEARSHIFT LINKAGE.....	11-14
TROUBLESHOOTING	11-4	CLUTCH INSTALLATION	11-18
RIGHT CRANKCASE COVER REMOVAL	11-5	RIGHT CRANKCASE COVER INSTALLATION	11-21
CLUTCH REMOVAL.....	11-7		

CLUTCH/GEARSHIFT LINKAGE COMPONENT LOCATION

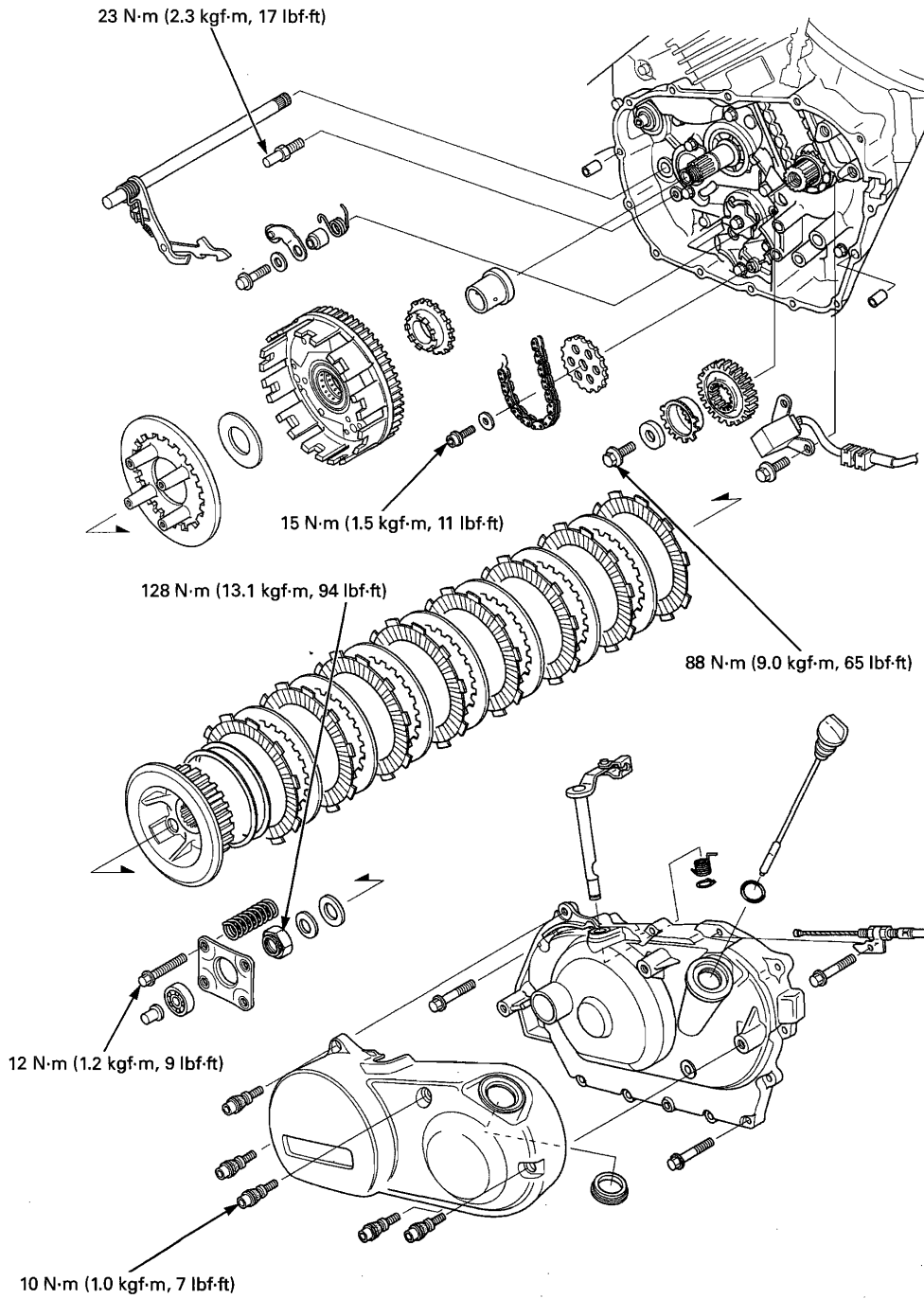

SERVICE INFORMATION

GENERAL

- The clutch and gearshift linkage can be serviced with the engine in the frame.
- Engine oil viscosity, oil level and the use of oil additives have an effect on clutch disengagement. Oil additives of any kind are specifically not recommended. When the clutch does not disengage or the motorcycle creeps with the clutch disengaged, inspect the engine oil and oil level before servicing the clutch system.

SPECIFICATIONS

ITEM		STANDARD	SERVICE LIMIT
Clutch lever freeplay		10 – 20 (3/8 – 13/16)	–
Clutch	Spring free length	45.3 (1.78)	43.9 (1.73)
	Disc thickness	Disc A	2.62 – 2.78 (0.103 – 0.109)
		End disc	2.92 – 3.08 (0.115 – 0.121)
	Plate warpage	–	0.30 (0.012)
Clutch outer guide	I.D.	21.991 – 22.016 (0.8658 – 0.8668)	22.03 (0.867)
	O.D.	31.959 – 31.975 (1.2582 – 1.2589)	31.92 (1.257)
Mainshaft O.D. at clutch outer guide		21.967 – 21.980 (0.8648 – 0.8654)	21.95 (0.864)
Clutch outer guide-to-mainshaft clearance		0.011 – 0.049 (0.0004 – 0.0019)	0.08 (0.003)
Clutch outer I.D.		32.000 – 32.025 (1.2598 – 1.2608)	32.09 (1.263)
Clutch outer-to-outer guide clearance		0.025 – 0.066 (0.0010 – 0.0026)	0.18 (0.007)
Oil pump drive sprocket I.D.		32.025 – 32.145 (1.2608 – 1.2655)	32.16 (1.266)
Oil pump drive sprocket-to-clutch outer guide clearance		0.050 – 0.186 (0.0020 – 0.0073)	0.23 (0.009)

TORQUE VALUES

Clutch lifter plate bolt	12 N·m (1.2 kgf·m, 9 lbf·ft)	Lock nut; replace with a new one and stake Apply engine oil to the threads and seating surface
Clutch center lock nut	128 N·m (13.1 kgf·m, 94 lbf·ft)	
Clutch cover socket bolt	10 N·m (1.0 kgf·m, 7 lbf·ft)	Apply engine oil to the threads and seating surface
Primary drive gear bolt	88 N·m (9.0 kgf·m, 65 lbf·ft)	
Gearshift arm pinch bolt	12 N·m (1.2 kgf·m, 9 lbf·ft)	Apply locking agent to the threads
Oil pump driven sprocket bolt	15 N·m (1.5 kgf·m, 11 lbf·ft)	
Gearshift pedal pivot bolt	39 N·m (4.0 kgf·m, 29 lbf·ft)	
Gearshift spindle return spring pin	23 N·m (2.3 kgf·m, 17 lbf·ft)	
Gearshift spindle oil seal stopper plate bolt	13 N·m (1.3 kgf·m, 10 lbf·ft)	

TOOLS

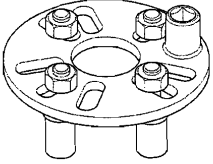
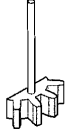
Clutch center holder 07JMB-MN50301  or 07HGB-001010B (plate) and 07HGB-001020B (collar) (U.S.A. only)	Gear holder, 2.5 07724-0010100  or 07724-001A100 (U.S.A. only)
---	--

TROUBLESHOOTING

Clutch lever too hard to pull in

- Damaged, kinked or dirty clutch cable
- Improperly routed clutch cable
- Damaged clutch lifter mechanism
- Faulty clutch lifter bearing

Clutch will not disengage or motorcycle creeps with clutch disengaged

- Too much clutch lever freeplay
- Warped clutch plates
- Loose clutch center lock nut
- Engine oil level too high, improper oil viscosity or oil additive used

Clutch slips

- No clutch lever freeplay
- Worn clutch discs
- Weak clutch springs
- Clutch lifter sticking
- Engine oil level too low or oil additive used

Hard to shift

- Improper clutch operation
- Incorrect engine oil viscosity
- Incorrect clutch adjustment
- Bent or damaged gearshift spindle
- Damaged gearshift cam
- Bent fork shaft or damaged shift forks and shift drum (page 13-21)

Transmission jumps out of gear

- Broken shift drum stopper arm
- Weak or broken gearshift spindle return springs
- Worn or damaged gearshift cam
- Bent fork shaft or worn shift forks and shift drum (page 13-21)
- Worn gear dogs or dog holes (page 13-21)

RIGHT CRANKCASE COVER REMOVAL

Drain the engine oil (page 4-13).

Remove the bolts, clutch cover and oil seal rubber.

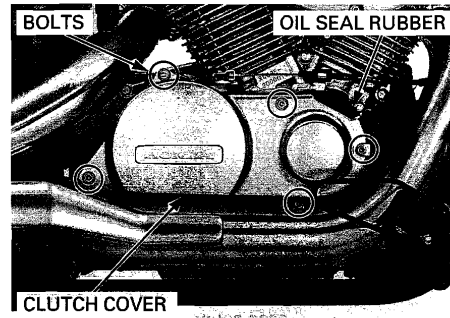

Remove the bolts in a crisscross pattern in several steps.

Remove the clutch cable holder and disconnect the clutch cable.

Remove the right crankcase cover.

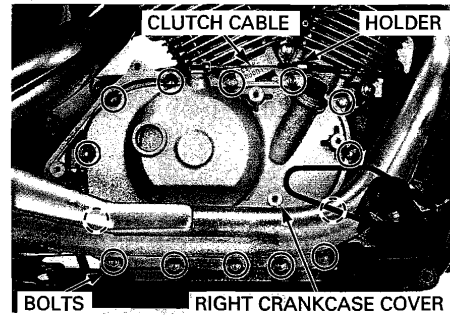

Be careful not to damage the mating surface. Remove the dowel pins and clean off the sealant from the mating surface.

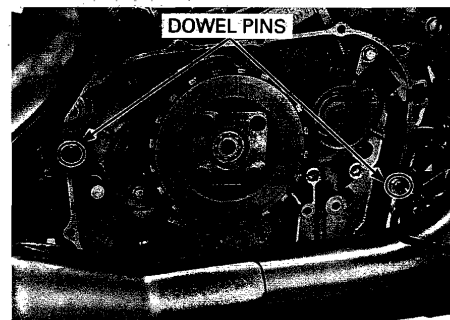
**DISASSEMBLY**

Remove the clutch lifter piece while turning the clutch lifter arm clockwise.

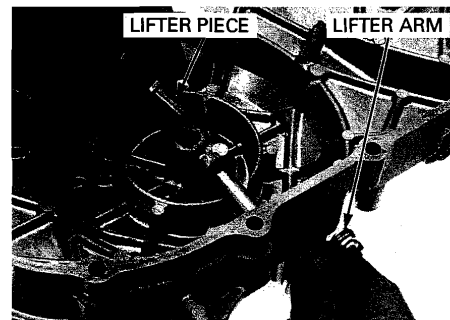

CLUTCH/GEARSHIFT LINKAGE

Remove the snap ring and return spring from the clutch lifter arm.

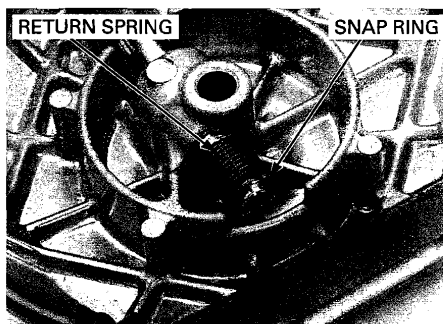

Remove the clutch lifter arm from the right crankcase cover.

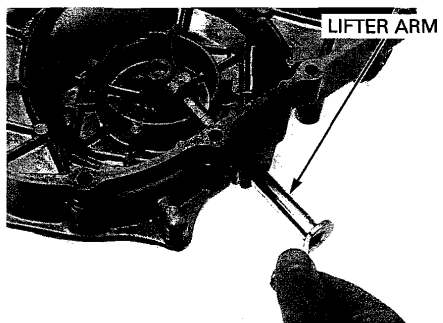

INSPECTION

Check the oil seal for fatigue or damage.
Check the lifter arm sliding surface of the right crankcase cover for wear, damage or loose fit.

Replace these parts if necessary.

NOTE:

If the oil seal replacement is required, install the oil seal flash with the case surface.

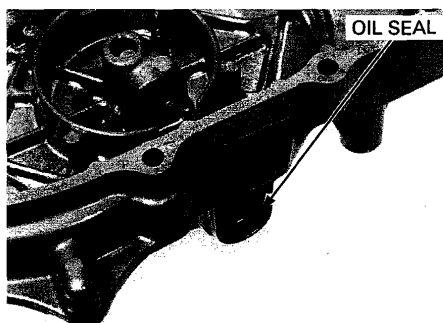

Check the clutch lifter arm for wear, damage or bending.
Check the spring for fatigue or damage.
Replace these parts if necessary.

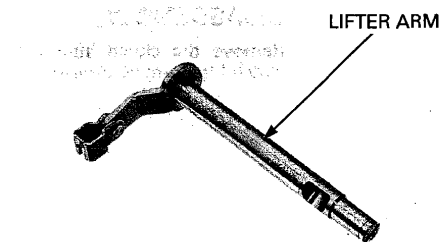

CLUTCH REMOVAL

Remove the right crankcase cover (page 11-5).

If the oil pump driven sprocket will be removed, loosen the driven sprocket bolt while the clutch is still installed.

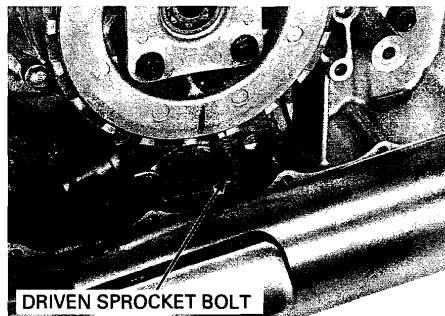

DRIVEN SPROCKET BOLT

Loosen the clutch lifter plate bolts in a crisscross pattern in several steps.
Remove the lifter plate/bearing and clutch springs.

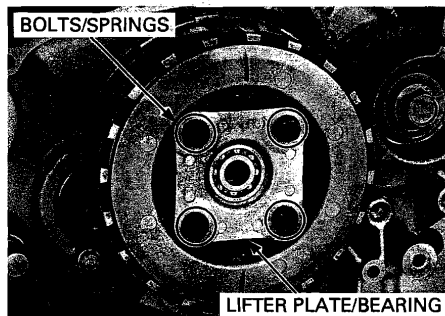

BOLTS/SPRINGS

LIFTER PLATE/BEARING

Be careful not to damage the mainshaft threads.

Unstake the clutch center lock nut.

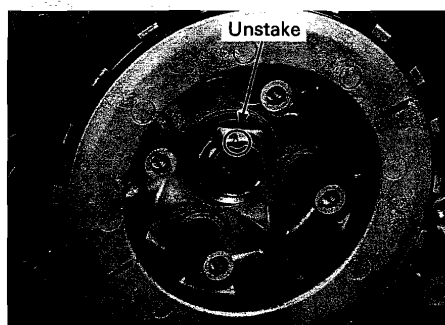

Unstake

Hold the clutch center using a special tool and loosen the clutch center lock nut.

TOOL:

Clutch center holder 07JMB-MN50301 or
07HGB-001010B (plate)
and
07HGB-001020B (collar)
(U.S.A. only)

Remove the special tool and clutch center lock nut.

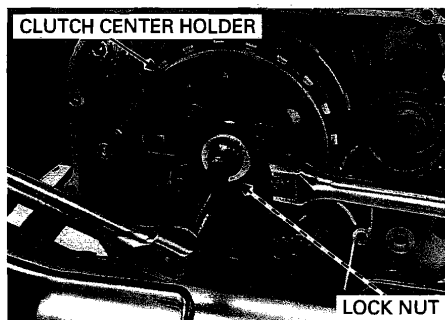

CLUTCH CENTER HOLDER

LOCK NUT

CLUTCH/GEARSHIFT LINKAGE

Remove the spring washer and thrust washer.

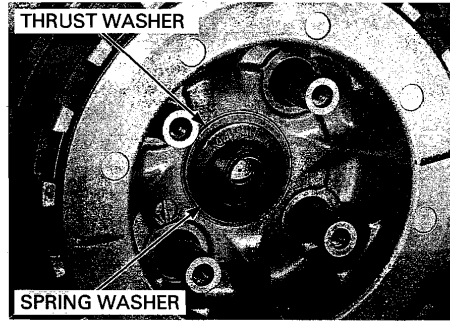

Remove the following:

- Clutch center
- Pressure plate
- End clutch disc
- Clutch plates
- Clutch disc A
- Judder spring
- Spring seat

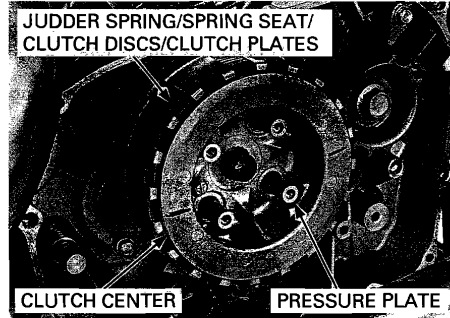

Remove the thrust washer and clutch outer.

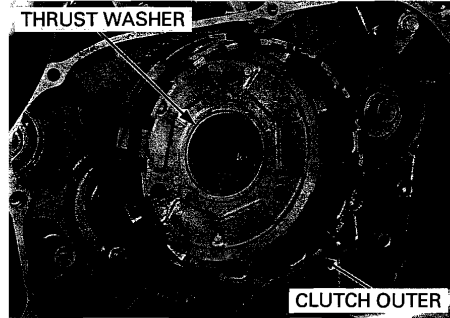

Remove the oil pump driven sprocket bolt and washer.

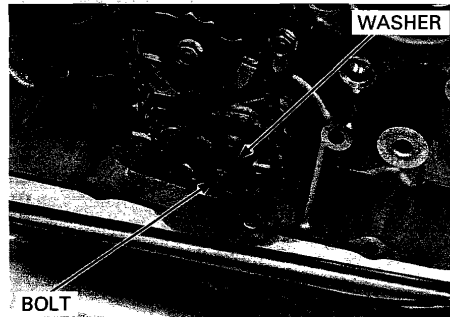

Remove the oil pump drive sprocket, driven sprocket and drive chain as a set.

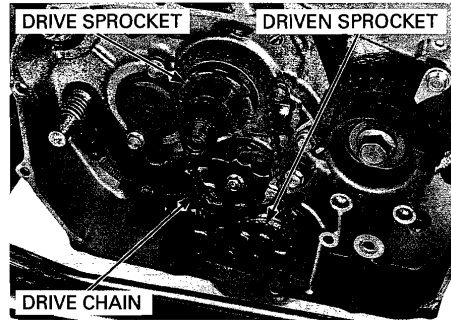

Remove the clutch outer guide.

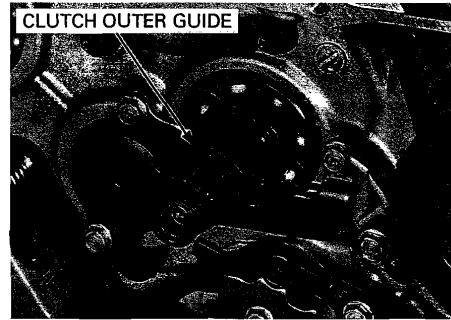

INSPECTION

CLUTCH LIFTER BEARING

Turn the inner race of the bearing with your finger. The bearings should turn smoothly and quietly. Also check that the bearing outer race fits tightly in the lifter plate.

Remove and discard the bearing if the races do not turn smoothly and quietly, or if they fit loosely in the lifter plate.

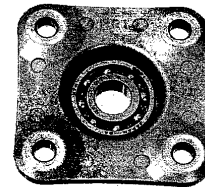

Replace the clutch springs as a set.

CLUTCH SPRING

Check the clutch spring free length.

SERVICE LIMIT: 43.9 mm (1.73 in)

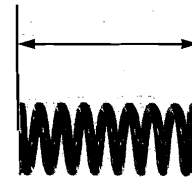

CLUTCH/GEARSHIFT LINKAGE

CLUTCH DISC

Replace the clutch discs and plates as a set.

Replace the clutch discs for signs of scoring or discoloration.

Measure the clutch disc thickness.

SERVICE LIMITS: Disc A: 2.3 mm (0.09 in)
End disc: 2.6 mm (0.10 in)

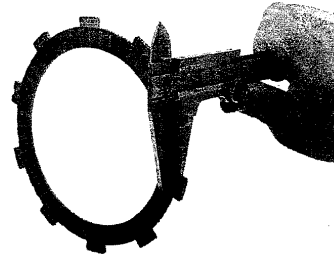

CLUTCH PLATE

Replace the clutch discs and plates as a set.

Check the clutch plate for discoloration.

Check the clutch plate warpage on a surface plate using a feeler gauge.

SERVICE LIMIT: 0.30 mm (0.012 in)

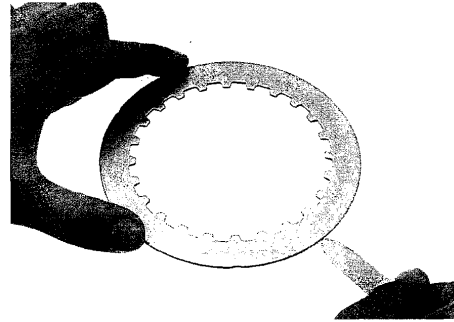

CLUTCH CENTER

Check the clutch center for nicks, indentations or abnormal wear caused by the clutch plates.

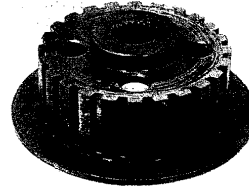

CLUTCH OUTER

Check the slot in the clutch outer for nicks, indentations or abnormal wear caused by the clutch discs.

Measure the clutch outer I.D.

SERVICE LIMIT: 32.09 mm (1.263 in)

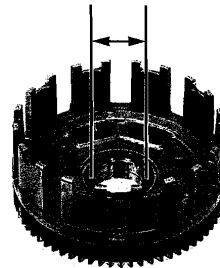

CLUTCH OUTER GUIDE

Check the clutch outer guide for damage or abnormal wear.

Measure the clutch outer guide I.D.

SERVICE LIMIT: 22.03 mm (0.867 in)

Measure the clutch outer guide O.D.

SERVICE LIMIT: 31.92 mm (1.257 in)

Calculate the clutch outer-to-outer guide clearance.

SERVICE LIMIT: 0.18 mm (0.007 in)

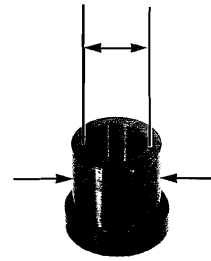

OIL PUMP DRIVE SPROCKET

Check the oil pump drive sprocket for wear or damage.

Measure the I.D. of the drive sprocket.

SERVICE LIMIT: 32.16 mm (1.266 in)

Calculate the oil pump drive sprocket-to-clutch outer guide clearance.

SERVICE LIMIT: 0.23 mm (0.009 in)

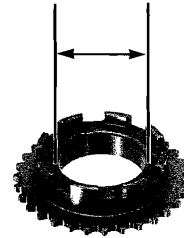

MAINSHAFT

Measure the mainshaft O.D. at the clutch outer guide sliding surface.

SERVICE LIMIT: 21.95 mm (0.864 in)

Calculate the clutch outer guide-to-mainshaft clearance.

SERVICE LIMIT: 0.08 mm (0.003 in)

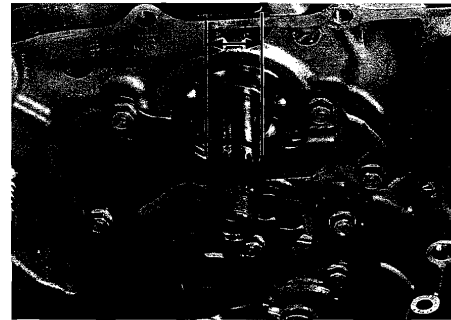

JUDDER SPRING/SPRING SEAT

Check the spring seat and judder spring for distortion, wear or damage.

SPRING SEAT

JUDDER SPRING

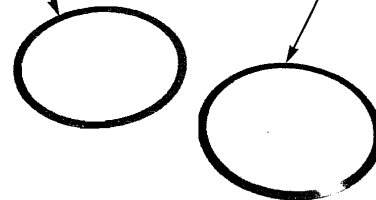

CLUTCH/GEARSHIFT LINKAGE

OIL PUMP DRIVEN SPROCKET

Check the oil pump driven sprocket for wear or damage.

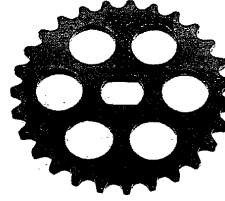

PRIMARY DRIVE GEAR

REMOVAL

Remove the clutch (page 11-7).

Remove the ignition pulse generator mounting bolts.

Remove the ignition pulse generator and grommets.

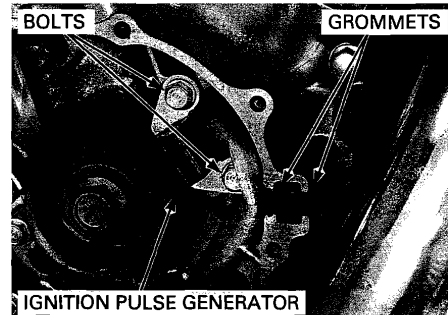

Temporarily install the clutch outer guide, oil pump drive sprocket and clutch outer onto the mainshaft (page 11-18).

Hold the primary drive gear using a special tool and remove the primary drive gear bolt and washer.

TOOL:

Gear holder, 2.5

**07724-0010100 or
07724-001A100
(U.S.A. only)**

Remove the gear holder and temporarily installed parts.

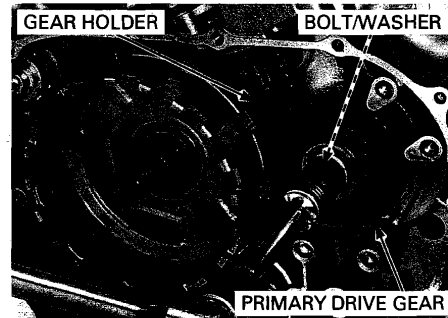

Remove the ignition pulse generator rotor and primary drive gear.

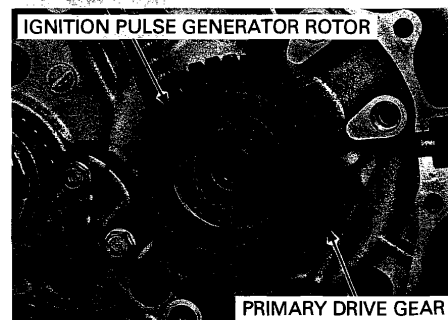

INSPECTION

Check the ignition pulse generator rotor for wear or damage.

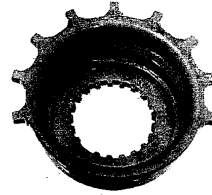

Check the primary drive gear for wear or damage.

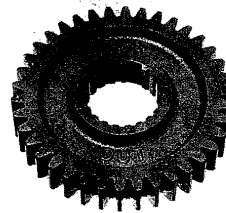
**INSTALLATION**

Install the primary drive gear on the crankshaft.

NOTE:

- Install the primary drive gear, aligning its wide groove with the wide tooth of the crankshaft.
- Install the primary drive gear with its "OUT" mark facing out.

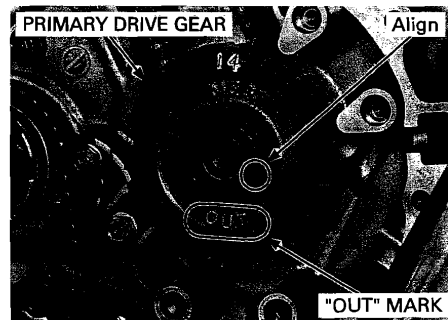

Install the ignition pulse generator rotor, aligning its wide groove with the wide tooth of the crankshaft.

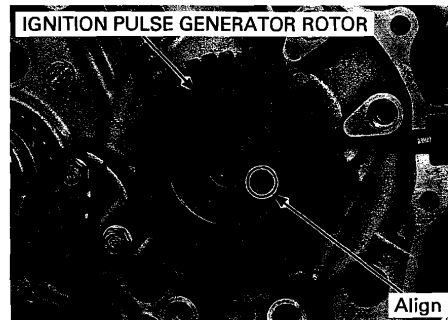

CLUTCH/GEARSHIFT LINKAGE

Temporarily install the clutch outer guide, oil pump drive sprocket and clutch outer onto the mainshaft.

Apply engine oil to the primary drive gear bolt threads and seating surface.

Install the washer and primary drive gear bolt.

Hold the primary drive gear using a special tool.

TOOL:

Gear holder, 2.5

07724-0010100 or
07724-001A100
(U.S.A. only)

Tighten the bolt to the specified torque.

TORQUE: 88 N·m (9.0 kgf·m, 65 lbf·ft)

Remove the gear holder and temporarily installed parts.

Install the ignition pulse generator, wire grommets and tighten the bolts.

Install the clutch (page 11-18).

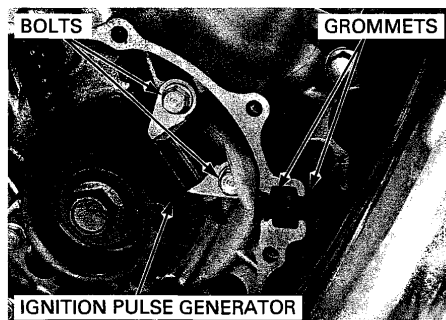
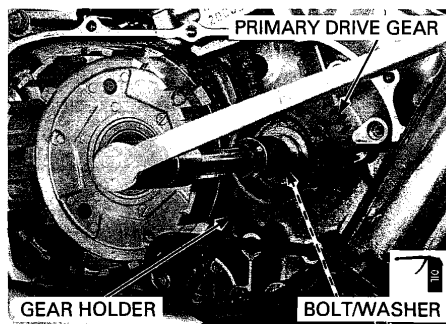

GEARSHIFT LINKAGE

REMOVAL

Remove the following:

- Left crankcase rear cover (page 3-5)
- Clutch (page 11-7)

Remove the pinch bolt and gearshift arm from the spindle.

Clean the gearshift spindle.

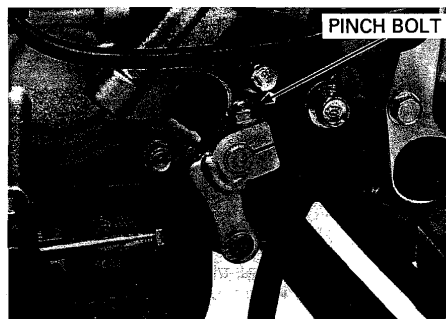

Remove the pivot bolt, washer and gearshift pedal.

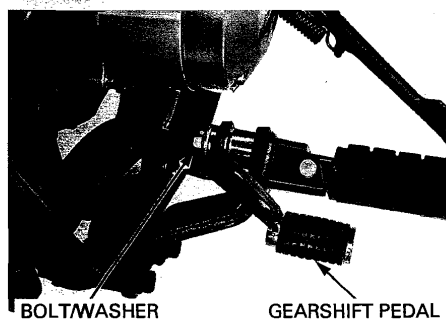

Remove the pivot collar and dust seals from the gearshift pedal.
 Check the dust seals for wear or damage.
 Replace the dust seal if necessary.

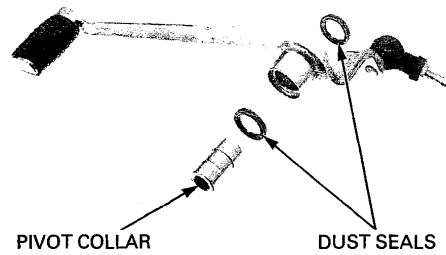

Remove the following:

- Bolt
- Washer
- Stopper arm
- Collar
- Return spring

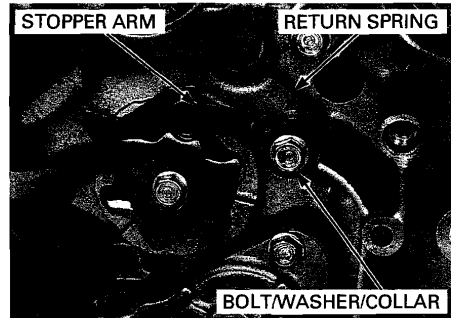

Remove the gearshift spindle from the crankcase while unhooking the shifter arm from the gearshift cam plate.

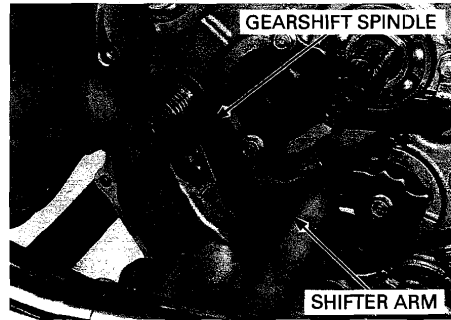

INSPECTION

Remove the bolt and stopper plate.

Apply grease to the oil seal lips.

Check the gearshift spindle oil seal for deterioration or damage, replace it if necessary.

NOTE:

Install the oil seal with its marked side facing out.

Install the stopper plate and tighten the bolt to the specified torque.

TORQUE: 13 N·m (1.3 kgf·m, 10 lbf·ft)

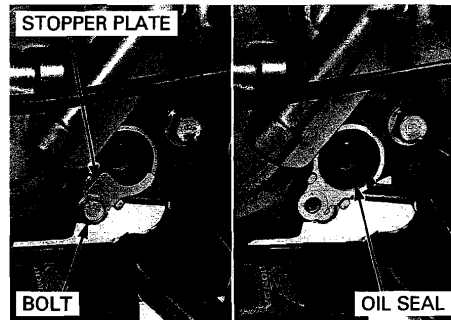

CLUTCH/GEARSHIFT LINKAGE

Check the gearshift spindle for bend, wear or damage.

Check the return springs for fatigue or damage.

RETURN SPRINGS

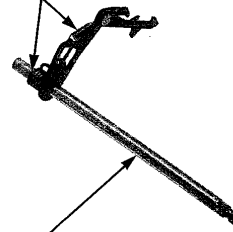

GEARSHIFT SPINDLE

Check the gearshift pedal rod for damage or loose lock nuts.
Replace the rod if necessary.

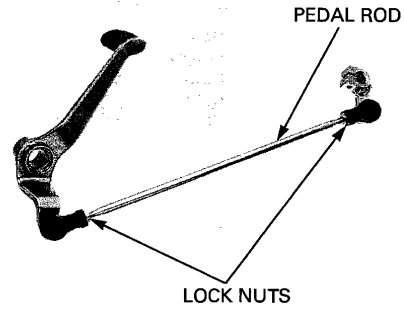

INSTALLATION

Install the gearshift spindle, aligning the return spring ends with the gearshift spindle return spring pin in the crankcase.

Hook the shifter arm to the gearshift cam plate.

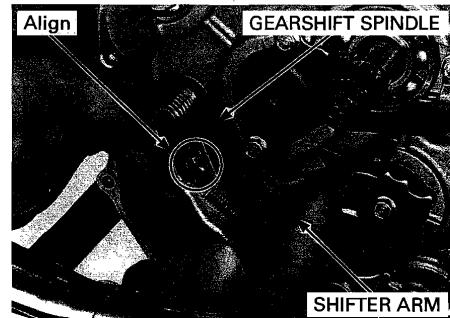

Install the following:

- Collar
- Return spring
- Stopper arm
- Washer
- Bolt

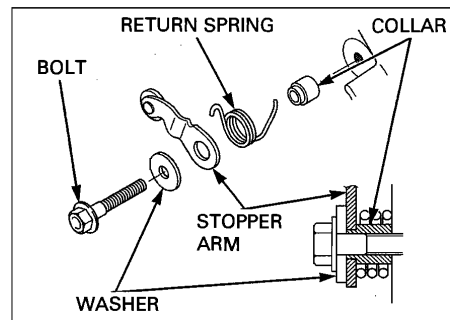

Hold the stopper arm with the screwdriver, and tighten the bolt securely as shown.

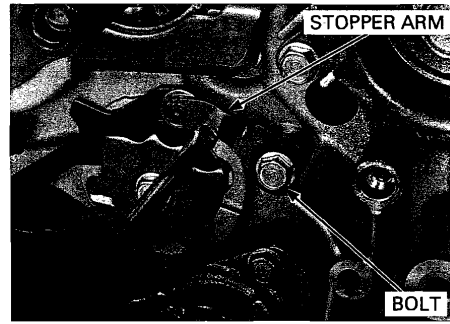

Apply grease to the dust seal lips. Install the dust seals and pivot collar to the gearshift pedal.

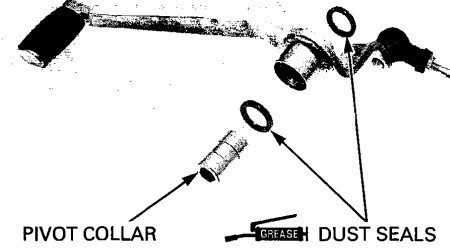

Install the gearshift pedal, washer and pivot bolt. Tighten the pivot bolt to the specified torque.

TORQUE: 39 N-m (4.0 kgf-m, 29 lbf-ft)

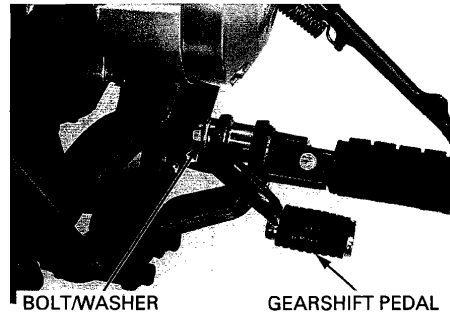

Install the gearshift arm to the spindle, aligning with the punch marks. Tighten the pinch bolt to the specified torque.

TORQUE: 12 N-m (1.2 kgf-m, 9 lbf-ft)

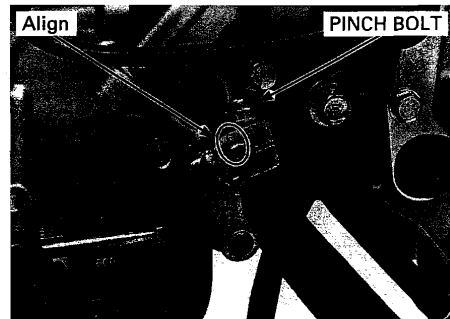

CLUTCH INSTALLATION

Apply molybdenum disulfide oil to the clutch outer guide outer surface.

Install the clutch outer guide to the mainshaft.



Install the oil pump drive chain, drive sprocket and driven sprocket as a set.

NOTE:

- Install the oil pump driven sprocket with the "O" marks side facing inside.
- Align the flat surfaces of the driven sprocket hole and oil pump shaft end.

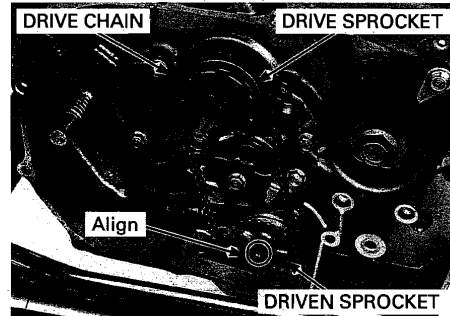

MARKS

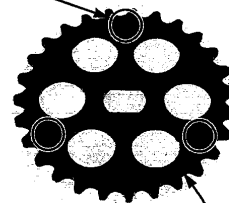

Apply locking agent to the oil pump driven sprocket bolt threads and install the washer and bolt.

NOTE:

Tighten the driven sprocket bolt to the specified torque after installing the clutch.

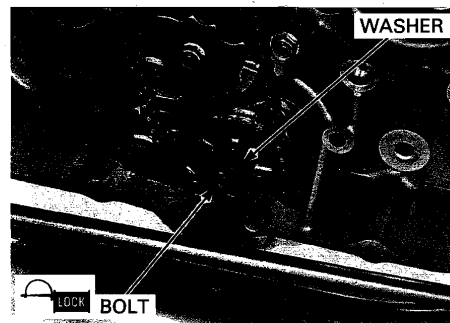

Install the clutch outer onto the mainshaft.

NOTE:

Align the grooves in the clutch outer with the bosses on the oil pump drive sprocket while turning the sprocket with the chain and pushing the clutch outer onto the mainshaft.

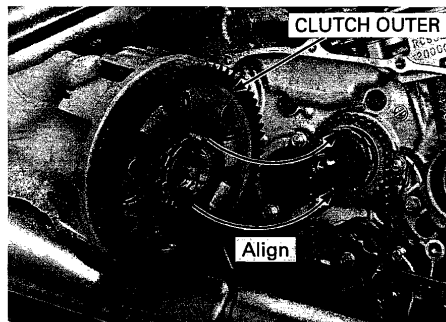

Install the thrust washer onto the mainshaft.

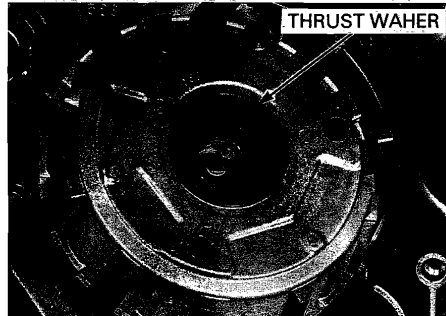

Coat the clutch discs and plates with engine oil. Install the spring seat and judder spring to the clutch center as shown.

End clutch disc has a larger I.D. than disc A.

Install the end clutch disc.
Install the seven clutch plates and seven discs A, starting with the clutch plate.
Install the pressure plate.

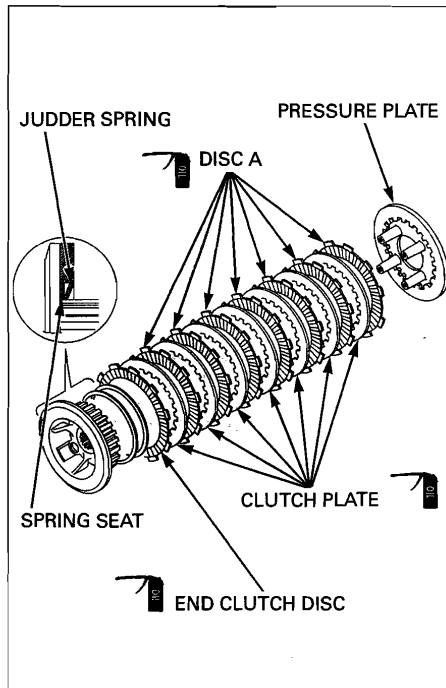

CLUTCH/GEARSHIFT LINKAGE

Install the clutch assembly into the clutch outer.

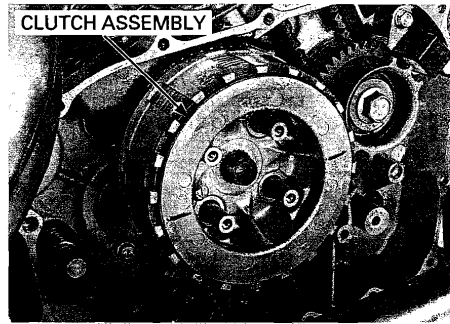

Install the end clutch disc into the shallow slots of the clutch outer.

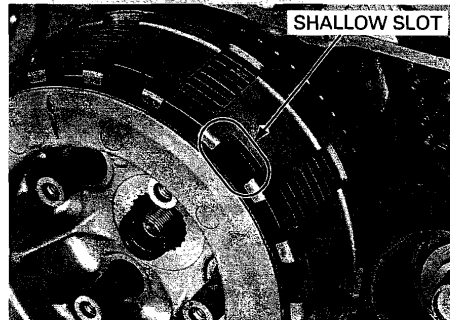

Install the thrust washer.

Install the spring washer with its "OUT SIDE" mark facing out.



Apply engine oil to the threads and seating surface of a new clutch center lock nut and install it onto the mainshaft.

Hold the clutch center using a special tool and tighten the lock nut to the specified torque.

TOOL:

Clutch center holder 07JMB-MN50301 or
 07HGB-001010B (plate)
 and
 07HGB-001020B (collar)
 (U.S.A. only)

TORQUE: 128 N·m (13.1 kgf·m, 94 lbf·ft)

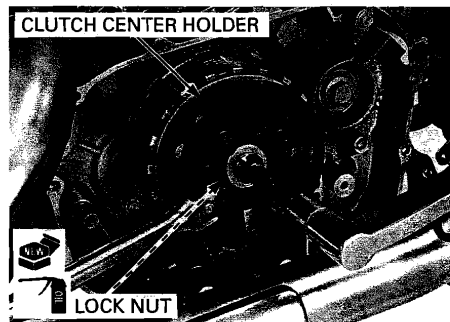

Be careful not to damage the mainshaft threads. Stake the clutch center lock nut into the mainshaft groove.

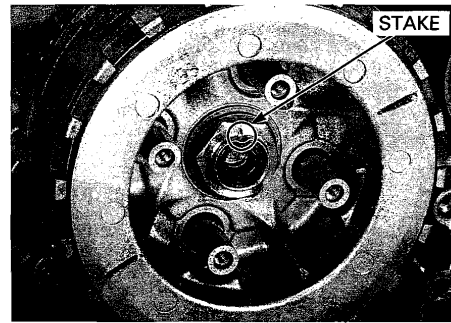

Install the clutch springs, lifter plate/bearing and bolts.
Tighten the bolts in a crisscross pattern in several steps to the specified torque.

TORQUE: 12 N·m (1.2 kgf·m, 9 lbf·ft)

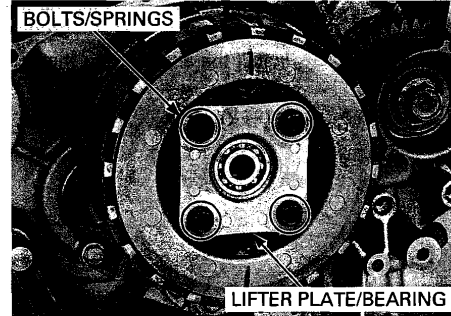

If the oil pump driven sprocket is removed, tighten the oil pump driven sprocket bolt to the specified torque.

TORQUE: 15 N·m (1.5 kgf·m, 11 lbf·ft)

Install the right crankcase cover (page 11-21).

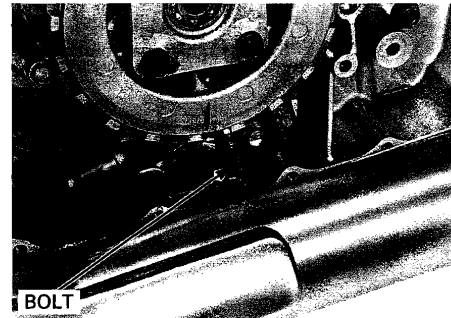

RIGHT CRANKCASE COVER INSTALLATION

ASSEMBLY

Apply engine oil to the clutch lifter arm sliding surface of the right crankcase cover.

Apply grease to the oil seal lips.

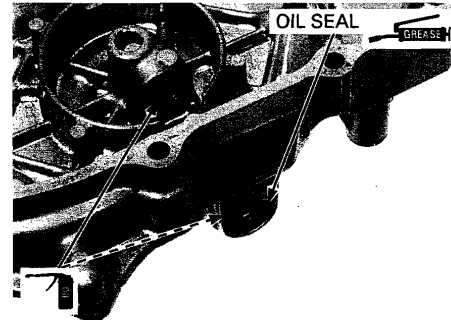

CLUTCH/GEARSHIFT LINKAGE

Apply engine oil to the clutch lifter arm sliding surface and slit.

Install the clutch lifter arm.

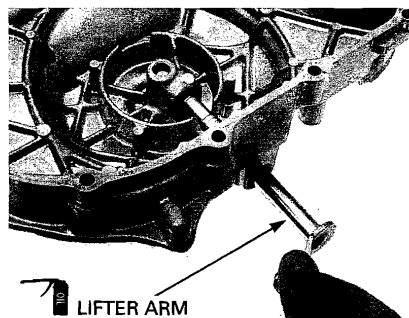

Install the return spring by inserting its short end into the clutch lifter arm groove.

Install the snap ring to the clutch lifter arm groove securely.

Hook the long spring end to the cover tab.

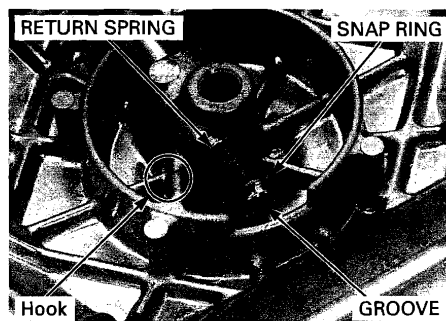

Install the clutch lifter piece, aligning the piece end with the groove in the clutch lifter arm by turning the clutch lifter arm clockwise.

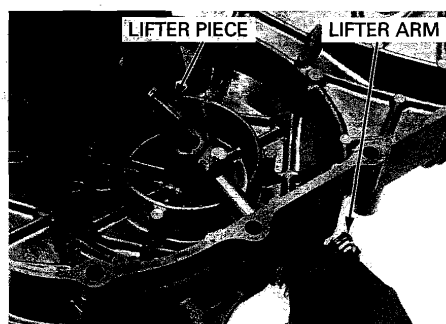

INSTALLATION

Install the dowel pins.

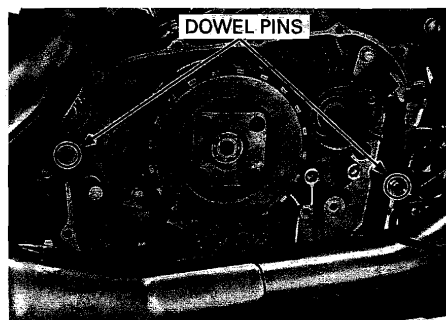

Be careful not to damage the mating surfaces.

Clean the mating surfaces of the right crankcase and cover.

Apply liquid sealant to the right crankcase cover mating surface.

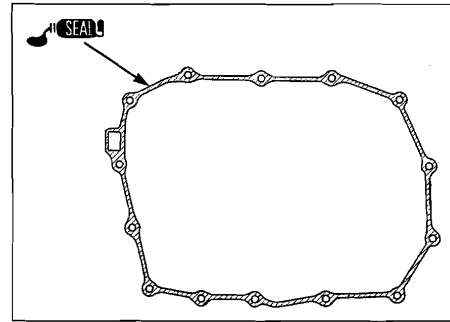

Connect the clutch cable.
Install the right crankcase cover, clutch cable holder and tighten the bolts in a crisscross pattern in several steps.

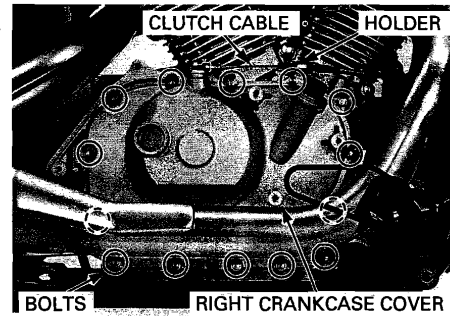

Install the oil seal rubber to the clutch cover with its small flange side facing up.

Install the clutch cover and tighten the bolts to the specified torque.

TORQUE: 10 N·m (1.0 kgf·m, 7 lbf·ft)

Fill the crankcase with the recommended engine oil (page 4-12).

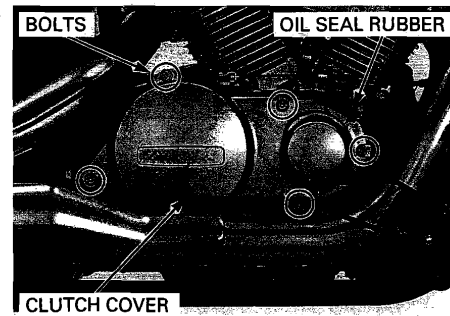

12. ALTERNATOR/STARTER CLUTCH

COMPONENT LOCATION	12-2	STATOR REMOVAL	12-4
SERVICE INFORMATION	12-3	FLYWHEEL/STARTER CLUTCH	12-5
TROUBLESHOOTING	12-3	STATOR INSTALLATION	12-11

COMPONENT LOCATION

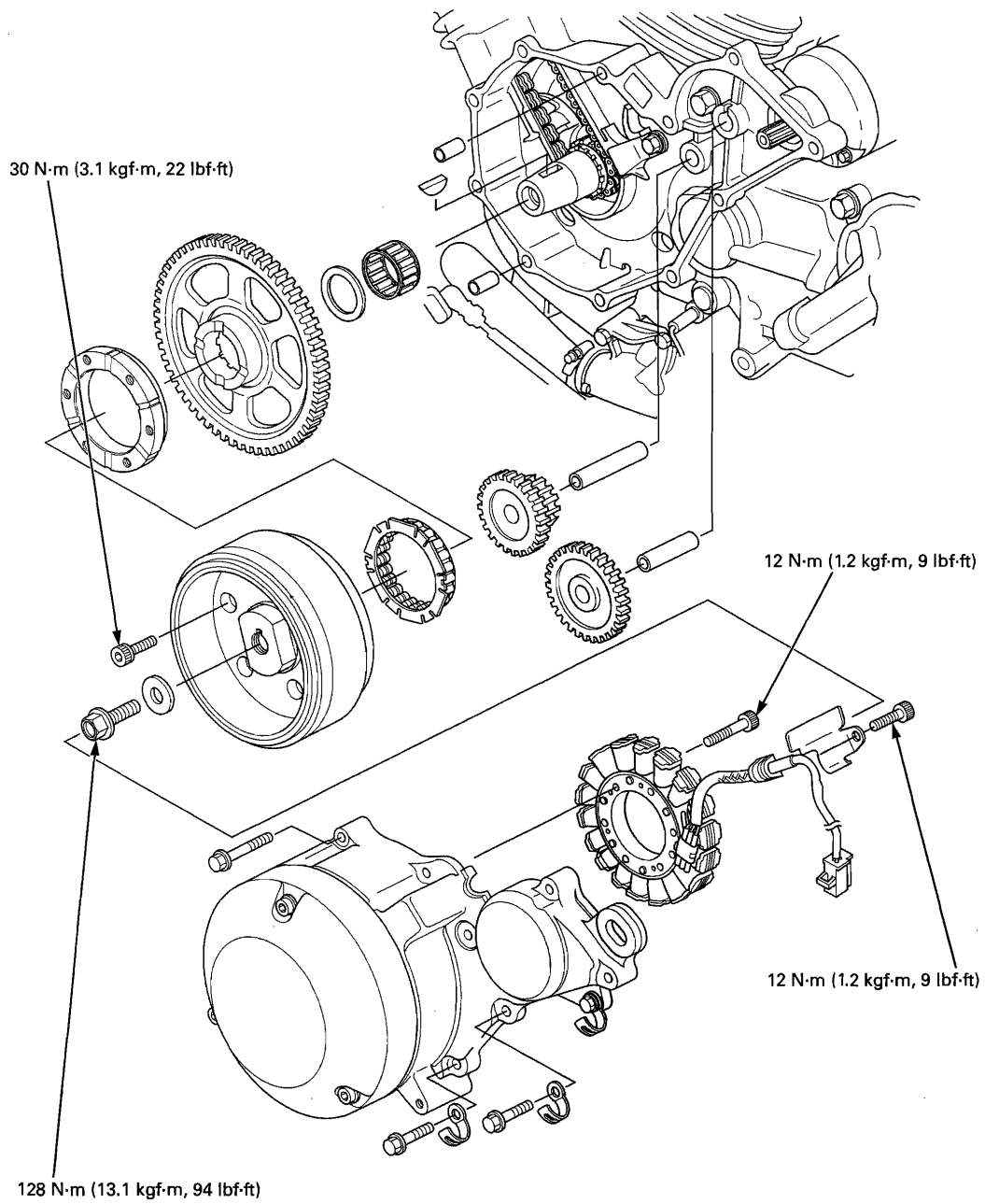

SERVICE INFORMATION

GENERAL

- This section covers service of the alternator stator and flywheel. All service can be done with the engine installed in the frame.
- For alternator inspection (page 18-9).
- For starter motor service (page 20-6).

SPECIFICATIONS

Unit: mm (in)

ITEM		STANDARD	SERVICE LIMIT
Starter driven gear	I.D.	37.000 – 37.025 (1.4567 – 1.4577)	37.10 (1.461)
	O.D.	57.749 – 57.768 (2.2736 – 2.2743)	57.73 (2.273)
Starter clutch outer I.D.		74.414 – 74.440 (2.9297 – 2.9307)	74.46 (2.931)

TORQUE VALUES

Stator socket bolt	12 N·m (1.2 kgf·m, 9 lbf·ft)	Apply locking agent to the threads
Flywheel bolt	128 N·m (13.1 kgf·m, 94 lbf·ft)	Apply engine oil to the threads and seating surface
		Left hand threads
Stator wire holder socket bolt	12 N·m (1.2 kgf·m, 9 lbf·ft)	Apply locking agent to the threads
Starter one-way clutch outer socket bolt	30 N·m (3.1 kgf·m, 22 lbf·ft)	Apply locking agent to the threads

TOOLS

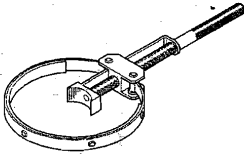
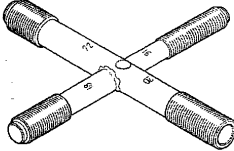
<p>Flywheel holder 07725-0040001</p>  <p>or equivalent commercially available in U.S.A.</p>	<p>Rotor puller 07733-0020001</p>  <p>or 07933-3290001 (U.S.A. only)</p>
--	---

TROUBLESHOOTING

Starter motor turns, but engine does not turn

- Faulty starter clutch
- Damaged reduction gear
- Damaged starter idle gear

STATOR REMOVAL

Remove the following:

- Seat (page 3-3)
- Left side cover (page 3-3)
- Left crankcase rear cover (page 3-5)

Disconnect the alternator 3P (Natural) connector.

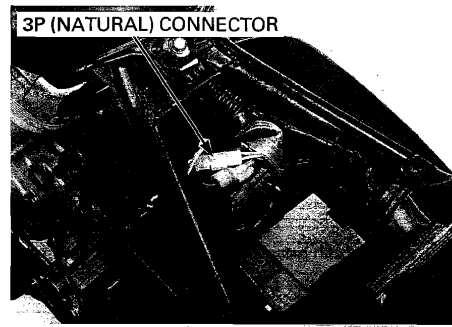

Release the wires from the clamps and wire bands.

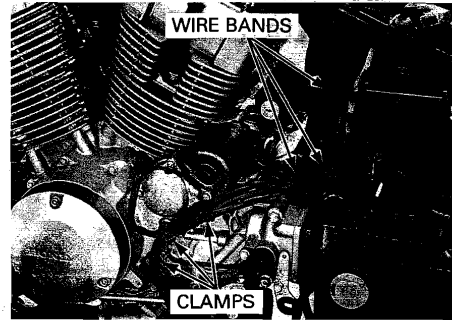

Place a container under the left crankcase cover to catch the engine oil.

Loosen the bolts in a crisscross pattern in several steps.

Remove the bolts, clamps and left crankcase cover.

NOTE:

- The left crankcase cover (stator) is magnetically attached to the flywheel, be careful during removal.
- Be careful not to damage the alternator cover.

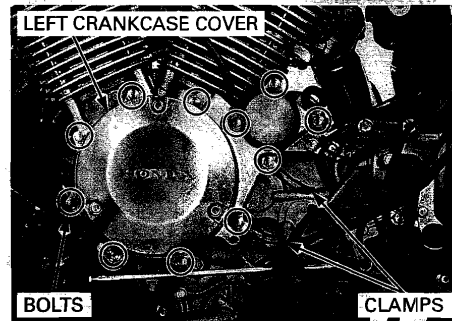

Be careful not to damage the mating surface.

Remove the dowel pins and clean off the sealant from the mating surface.

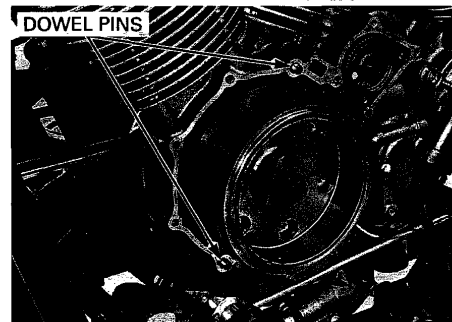

ALTERNATOR/STARTER CLUTCH

Remove the bolt and stator wire holder from the left crankcase cover.
Remove the wire grommet.

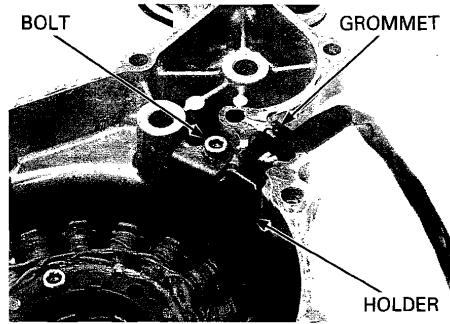

Remove the bolts and stator from the left crankcase cover.

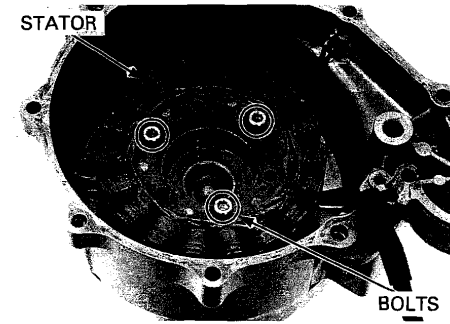

FLYWHEEL/STARTER CLUTCH

FLYWHEEL REMOVAL

For alternator charging coil inspection (page 18-9). Remove the left crankcase cover (page 12-4).
Remove the starter reduction gear and shaft.
Remove the starter idle gear and shaft.

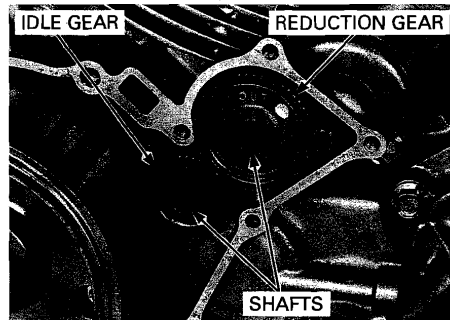

The flywheel bolt has left hand threads. Remove the flywheel bolt and washer while holding the flywheel using a special tool.

TOOL:
Flywheel holder

07725-0040001 or equivalent commercially available in U.S.A.



ALTERNATOR/STARTER CLUTCH

Remove the flywheel using a special tool.

TOOL:

Rotor puller

07733-0020001 or
07933-3290001
(U.S.A. only)

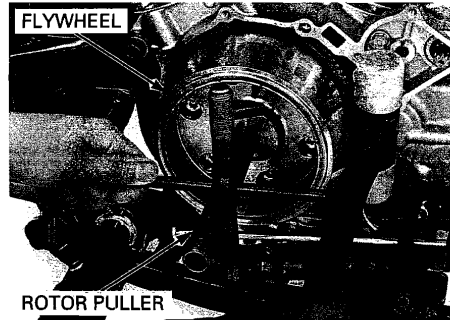

Remove the washer, needle bearing and woodruff key from the crankshaft.

NOTE:

- During woodruff key removal, be careful not to damage the key groove and crankshaft.
- Do not lose the woodruff key.

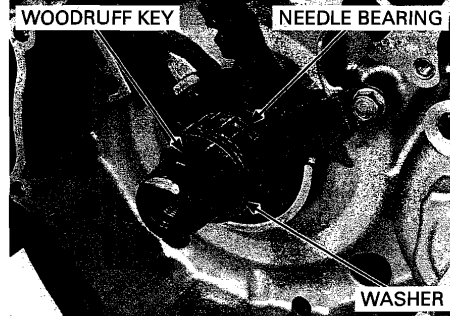

STARTER IDLE/REDUCTION GEAR INSPECTION

STARTER IDLE GEAR/SHAFT

Check the starter idle gear and shaft for wear or damage.

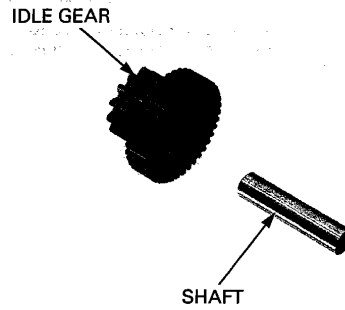

STARTER REDUCTION GEAR/SHAFT

Check the starter reduction gear and shaft for wear or damage.

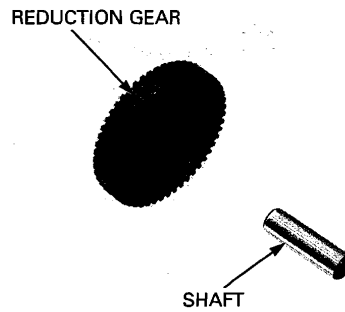

STARTER DRIVEN GEAR/STARTER CLUTCH REMOVAL

Check the operation of the one-way clutch by turning the starter driven gear. You should be able to turn the driven gear counterclockwise smoothly, but the gear should not turn clockwise.

Remove the starter driven gear from the flywheel while turning the driven gear counterclockwise.

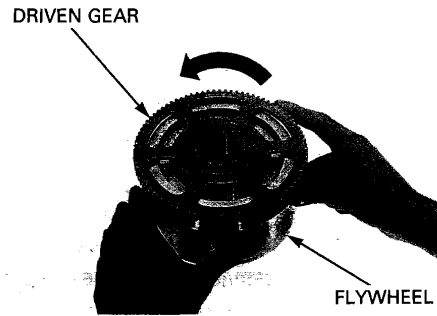

Remove the socket bolts while holding the flywheel using a special tool.

TOOL:
Flywheel holder

07725-0040001 or equivalent commercially available in U.S.A.

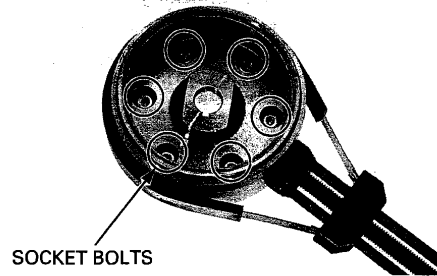

Remove the starter clutch outer/one-way clutch from the flywheel.

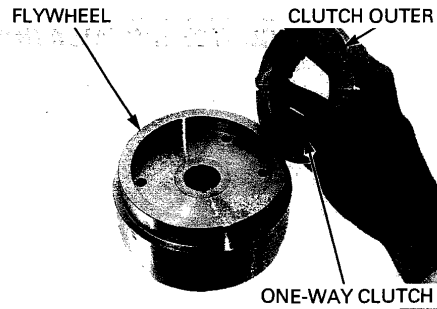

STARTER CLUTCH INSPECTION

NEEDLE BEARING

Check the needle bearing for abnormal wear or damage.

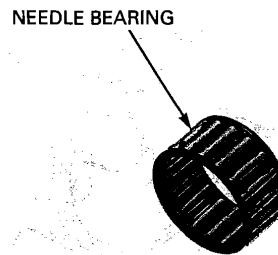

ALTERNATOR/STARTER CLUTCH

ONE-WAY CLUTCH/STARTER CLUTCH OUTER

Check the one-way clutch sprag for abnormal wear, damage or irregular movement.

NOTE:

- Do not remove the one-way clutch from the clutch outer, unless it is necessary to replace with a new one.
- If the spring is removed from the one-way clutch groove, replace the one-way clutch assembly with a new one.

Check the starter clutch outer inner contact surface for wear or damage.

Measure the starter clutch outer I.D.

SERVICE LIMIT: 74.46 mm (2.931 in)

STARTER DRIVEN GEAR

Check the one-way clutch sprag contact surface for wear or damage.

Measure the starter driven gear O.D.

SERVICE LIMIT: 57.73 mm (2.273 in)

Measure the starter driven gear I.D.

SERVICE LIMIT: 37.10 mm (1.461 in)

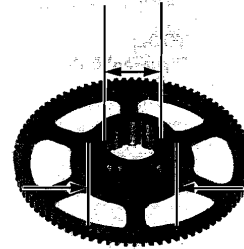
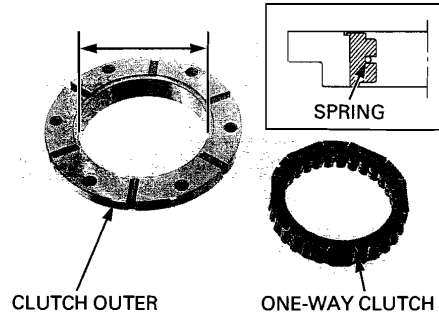

STARTER DRIVEN GEAR/STARTER CLUTCH INSTALLATION

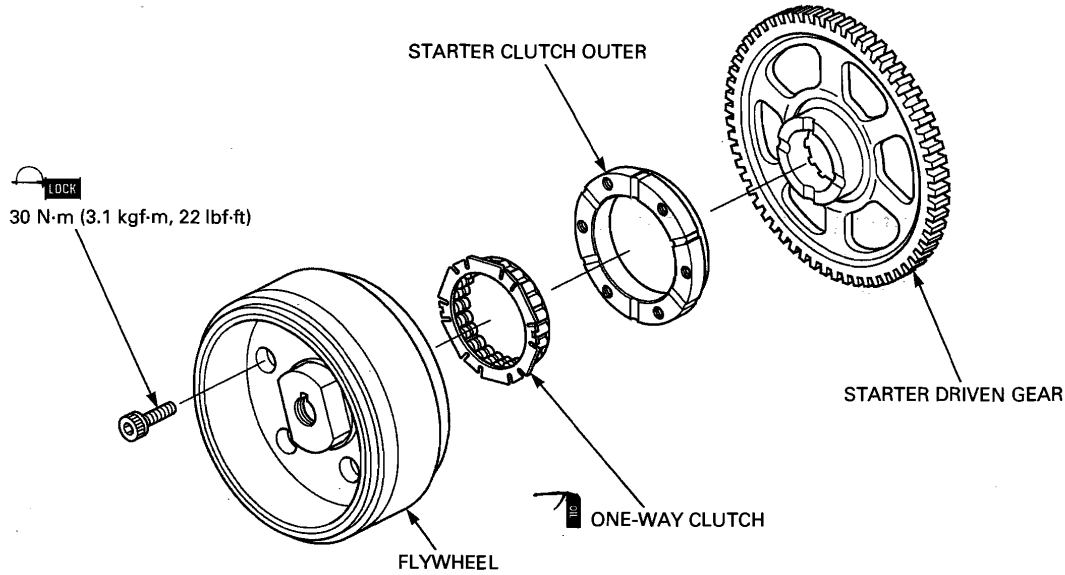

Clean the one-way clutch and apply engine oil to the sprag.
Install the one-way clutch into the starter clutch outer with its flange side facing the flywheel.

NOTE:

If the spring is removed from the one-way clutch groove, replace the one-way clutch assembly with a new one.

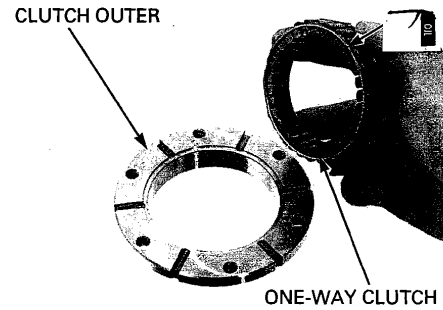

Install the starter clutch outer/one-way clutch to the flywheel.

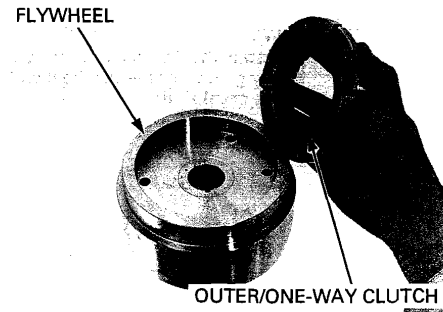

Hold the flywheel using a special tool.

TOOL:
Flywheel holder

07725-0040001 or
equivalent com-
mercially avail-
able in U.S.A.

Clean and apply a locking agent to the socket bolt threads.
Install and tighten the socket bolts to the specified torque.

TORQUE: 30 N·m (3.1 kgf·m, 22 lbf·ft)

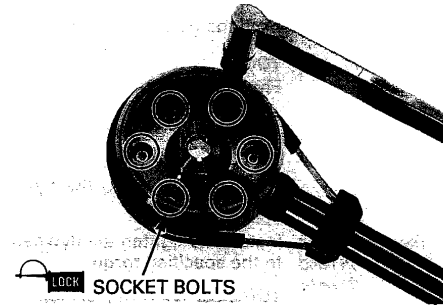

Install the starter driven gear to the flywheel while turning the driven gear counterclockwise.

Recheck the one-way clutch operation (page 12-7).

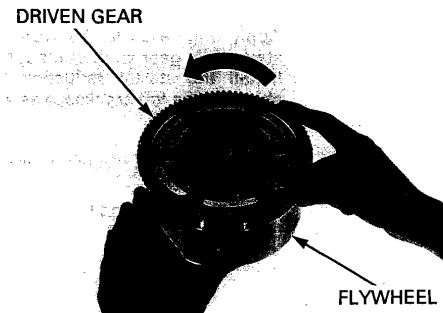

ALTERNATOR/STARTER CLUTCH

FLYWHEEL INSTALLATION

During woodruff key installation, be careful not to damage the key groove or crankshaft.

Install the woodruff key to the key groove of the crankshaft.
Apply engine oil to the needle bearing and install it to the crankshaft.
Install the washer to the crankshaft.
Wipe any oil off the mating surface of the crankshaft.

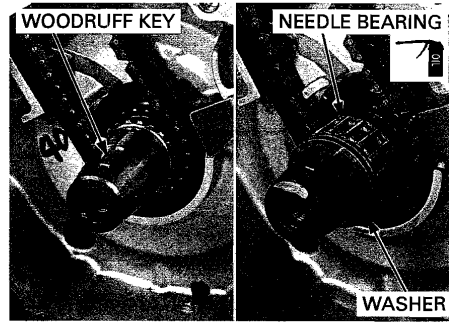

Wipe any oil off the mating surface of the flywheel. Install the flywheel to the crankshaft, aligning the key groove of the flywheel with the woodruff key on the crankshaft.

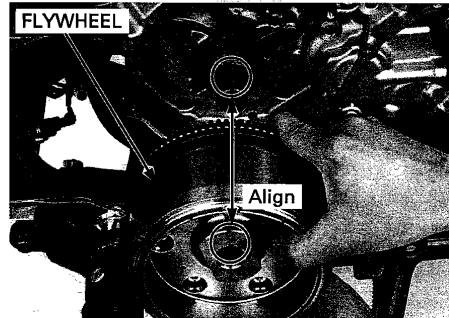

Hold the flywheel using a special tool.

TOOL:

Flywheel holder

07725-0040001 or equivalent commercially available in U.S.A.

Apply engine oil to the flywheel bolt threads and seating surface.

The flywheel bolt has left hand threads.

Install and tighten the flywheel bolt with the washer to the specified torque.

TORQUE: 128 N·m (13.1 kgf·m, 94 lbf·ft)

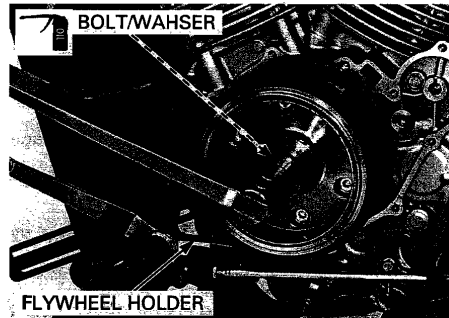

Apply engine oil to the starter reduction gear and starter idle gear shaft outer surface. Install the starter reduction gear, idle gear and shafts to the left crankcase as an assembly.

NOTE:

Install the starter reduction gear with its "OUT" mark facing out.

Install the stator and left crankcase cover (page 12-11).

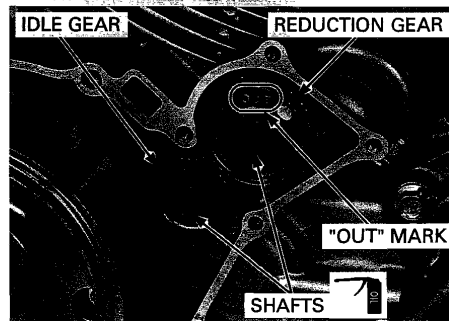

STATOR INSTALLATION

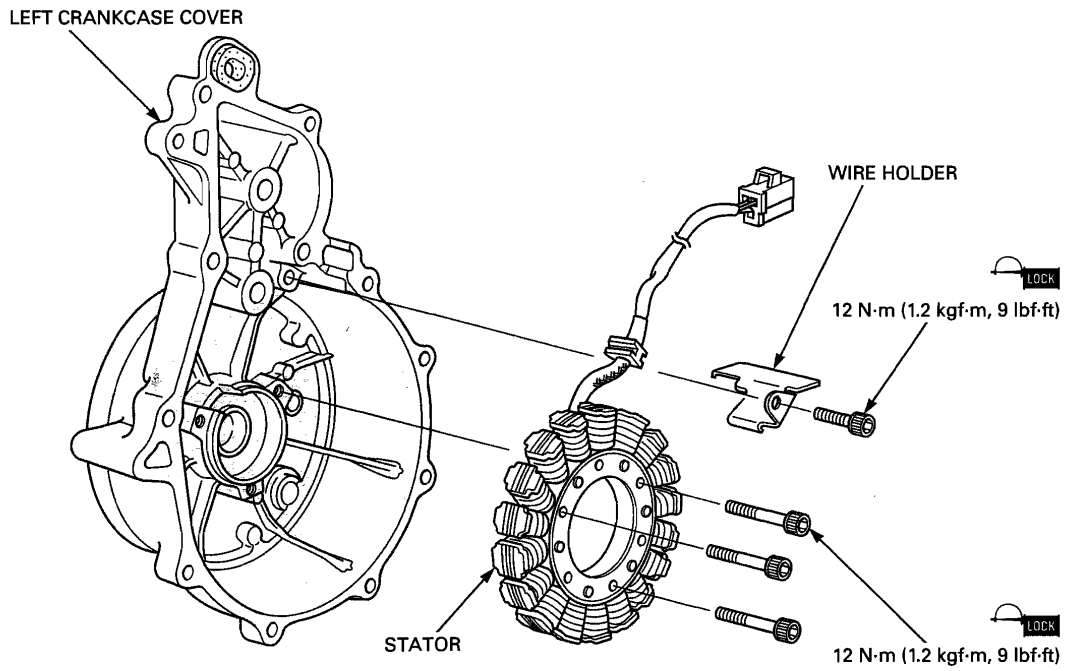

Install the stator to the left crankcase cover.
 Clean and apply a locking agent to the bolt threads (page 1-19).
 Install and tighten the stator socket bolts to the specified torque.

TORQUE: 12 N·m (1.2 kgf·m, 9 lbf·ft)

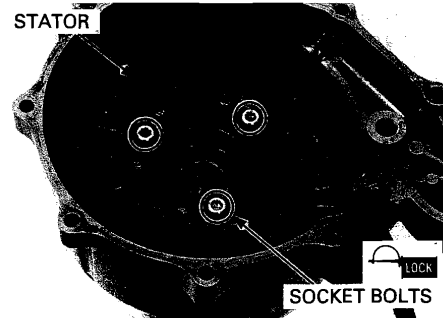

Install the grommet into the grooves in the left crankcase cover.

Clean and apply a locking agent to the bolt threads (page 1-19).
 Install the wire holder to the left crankcase cover.
 Install and tighten the bolt to the specified torque.

TORQUE: 12 N·m (1.2 kgf·m, 9 lbf·ft)

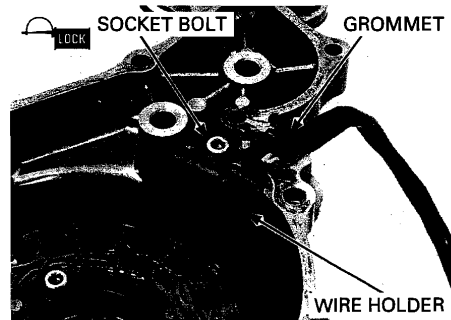

ALTERNATOR/STARTER CLUTCH

Clean off the sealant from the left crankcase cover mating surface.

Do not wipe off the excessive sealant by using the organic solvent.

Apply liquid sealant to the left crankcase cover mating surface.

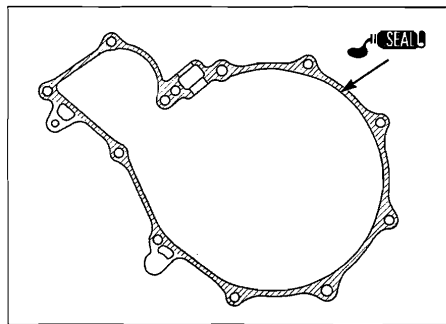

Install the dowel pins.

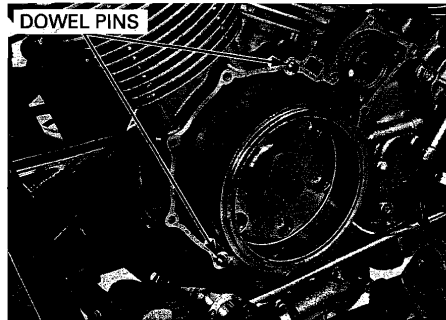

The left crankcase cover (stator) is magnetically attracted to the flywheel, be careful during installation.

Install the left crankcase cover.

Apply locking agent to the one left crankcase cover bolt (marked "△") threads as shown.

Install the clamps and left crankcase cover bolts. Tighten the left crankcase cover bolts in a crisscross pattern in several steps.

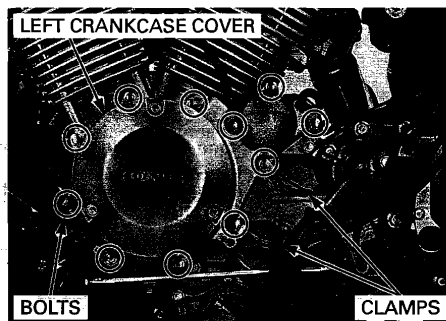
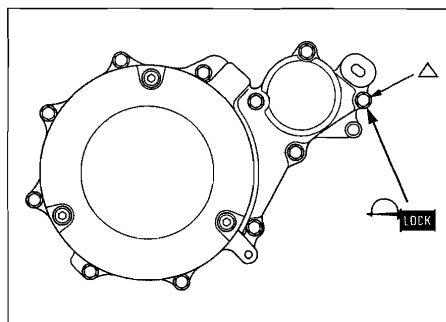

Route the wires properly (page 1-22).
Clamp and bind the wires with wire bands.

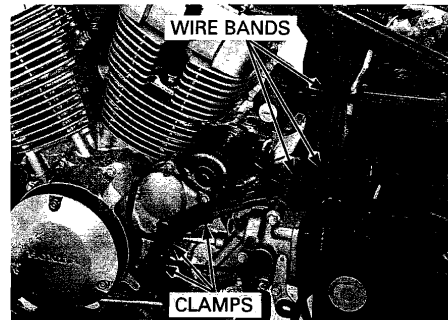

Connect the alternator 3P (Natural) connector.

Install the following:

- Left crankcase rear cover (page 3-5)
- Left side cover (page 3-3)
- Seat (page 3-3)

Check the engine oil level (page 4-12).



13. CRANKSHAFT/TRANSMISSION

COMPONENT LOCATION	13-2	MAIN JOURNAL BEARING	13-16
SERVICE INFORMATION	13-3	TRANSMISSION.....	13-20
TROUBLESHOOTING	13-8	OUTPUT GEAR.....	13-28
CRANKCASE SEPARATION.....	13-9	CRANKCASE BEARING REPLACEMENT	13-47
CRANKSHAFT/CONNECTING ROD	13-10	CRANKCASE ASSEMBLY.....	13-49
CRANKPIN BEARING	13-13		

COMPONENT LOCATION

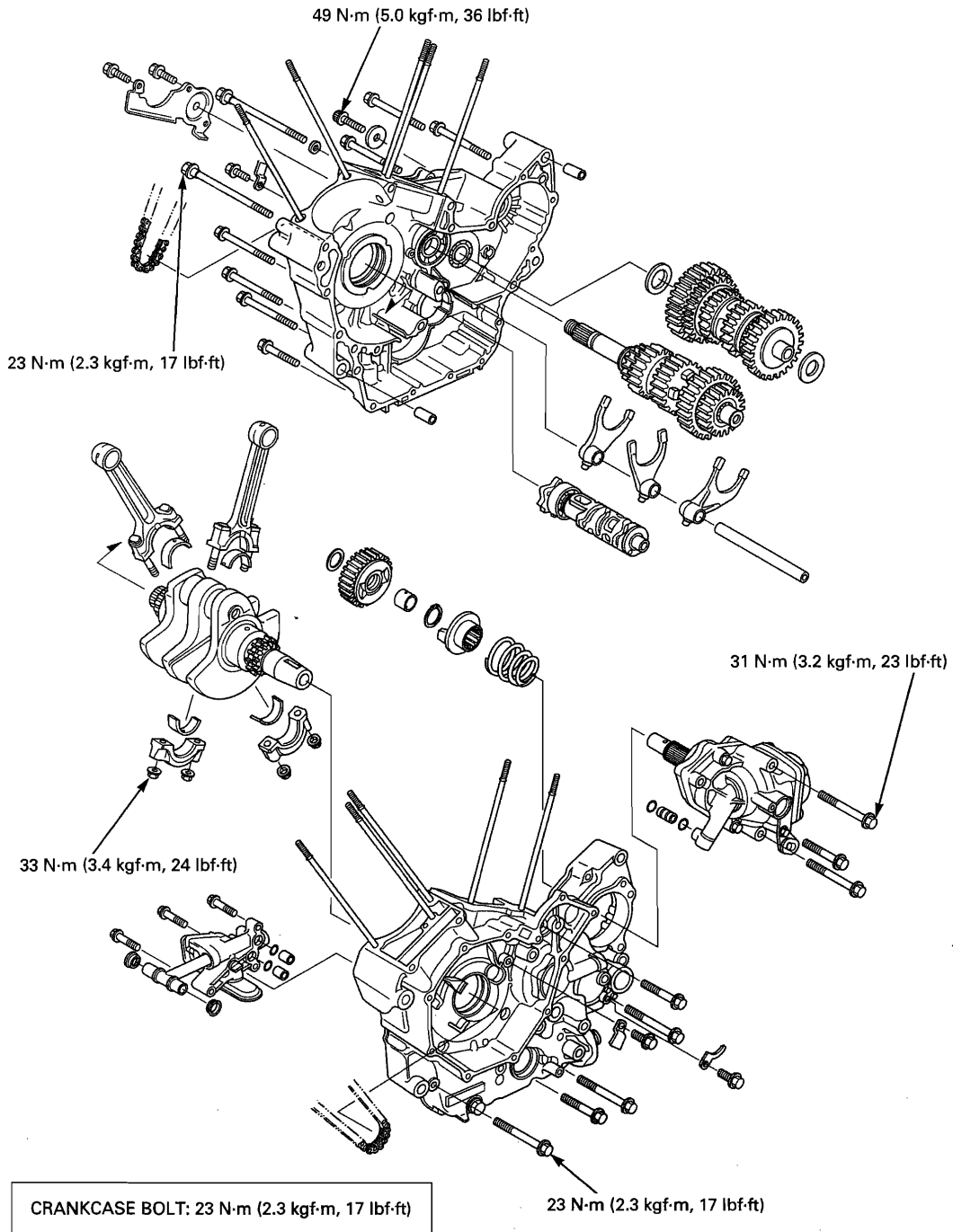

SERVICE INFORMATION

GENERAL

- The crankcase must be separated to service the following:
 - Oil pump
 - Crankshaft/connecting rod
 - Output gear
 - Transmission
- The following parts must be removed before separating the crankcase:
 - Oil filter cartridge (page 4-13)
 - Water pump (page 7-16)
 - Cylinder head (page 9-14)
 - Cylinder (page 10-4), piston (page 10-5)
 - Clutch (page 11-7), gearshift linkage (page 11-14) and primary drive gear (page 11-12)
 - Flywheel (page 12-5)
 - Starter motor (page 20-6)
 - VS sensor (page 21-11)
 - Neutral switch (page 21-19)
 - EOP switch (page 5-5)
 - Intake manifold (page 6-23)
- Be careful not to damage the crankcase mating surfaces when servicing.
- Mark and store the connecting rods, bearing caps and bearing inserts to be sure of their correct locations for reassembly.
- The crankpin and main journal bearing inserts are select fit and are identified by color codes. Select replacement bearings from the code tables. After selecting new bearings, recheck the oil clearance. Incorrect oil clearance can cause major engine damage.
- Prior to assembling the crankcase halves, apply sealant to their mating surfaces. Wipe off excess sealant thoroughly.
- Whenever you replace the output driven/drive gears, bearings, bearing holder or gear case, perform the gear contact pattern and backlash inspection and adjust the shim. The extension lines from the gear engagement surfaces should intersect at one point.
- When using the lock nut wrench for the output gear case, use a deflecting beam type torque wrench 20 inches long. The lock nut wrench increases the torque wrench's leverage, so the torque wrench reading will be less than the torque actually applied to the lock nut. The specification given is the actual torque applied to the lock nut, not the reading on the torque wrench. Do not over tighten the lock nuts. The specification later in the text gives both actual and indicated.
- Protect the output gear case with a shop towel or soft jaws while holding it in vise. Do not clamp it too tightly as it could damage the gear case.

CRANKSHAFT/TRANSMISSION

SPECIFICATIONS

Unit: mm (in)





ITEM		STANDARD	SERVICE LIMIT	
Crankshaft	Connecting rod big end side clearance	0.05 – 0.20 (0.002 – 0.008)	0.30 (0.012)	
	Crankpin bearing oil clearance	0.028 – 0.052 (0.0011 – 0.0020)	0.07 (0.003)	
	Main journal oil clearance	0.020 – 0.038 (0.0008 – 0.0015)	0.07 (0.003)	
	Crankshaft runout	–	0.03 (0.001)	
	Main journal O.D.	52.982 – 53.000 (2.0859 – 2.0866)	52.976 (2.0857)	
Main journal I.D.		58.010 – 58.022 (2.2839 – 2.2843)	58.070 (2.2862)	
Shift fork, fork shaft	I.D.	13.000 – 13.018 (0.5118 – 0.5125)	13.03 (0.513)	
	Claw thickness	5.93 – 6.00 (0.233 – 0.236)	5.6 (0.22)	
	Fork shaft O.D.	12.966 – 12.984 (0.5105 – 0.5112)	12.90 (0.508)	
Shift drum O.D. at left end		11.966 – 11.984 (0.4711 – 0.4718)	11.94 (0.470)	
Shift drum journal I.D.		12.000 – 12.018 (0.4724 – 0.4731)	12.05 (0.474)	
Shift drum-to-shift drum journal clearance		0.016 – 0.052 (0.0006 – 0.0020)	0.09 (0.035)	
Transmission	Gear I.D.	M3, M5	28.000 – 28.021 (1.1024 – 1.1032)	28.04 (1.104)
		C1, C4	31.000 – 31.025 (1.2205 – 1.2215)	31.05 (1.222)
		C2	24.000 – 24.021 (0.9449 – 0.9457)	24.04 (0.946)
	Gear busing O.D.	M3, M5	27.959 – 27.980 (1.1007 – 1.1016)	27.94 (1.100)
		C1, C4	30.950 – 30.975 (1.2185 – 1.2195)	30.93 (1.218)
		C2	23.959 – 23.980 (0.9433 – 0.9441)	23.94 (0.943)
	Gear-to-bushing clearance	M3, M5, C2	0.020 – 0.062 (0.0008 – 0.0024)	0.10 (0.004)
		C1, C4	0.025 – 0.075 (0.0010 – 0.0030)	0.11 (0.004)
	Gear bushing I.D.	M3	25.000 – 25.021 (0.9843 – 0.9851)	25.04 (0.986)
		C2	20.000 – 20.021 (0.7874 – 0.7882)	20.04 (0.789)
	Mainshaft O.D.	at M3 bushing	24.959 – 24.980 (0.9826 – 0.9835)	24.94 (0.982)
	Countershaft O.D.	at C2 bushing	19.980 – 19.993 (0.7866 – 0.7871)	19.96 (0.786)
	Bushing-to-shaft clearance	M3	0.020 – 0.062 (0.0008 – 0.0024)	0.10 (0.004)
		C2	0.007 – 0.041 (0.0003 – 0.0016)	0.07 (0.003)
Output drive train	Output gear I.D.	24.000 – 24.021 (0.9449 – 0.9457)	24.04 (0.946)	
	Output gear bushing	O.D.	23.959 – 23.980 (0.9433 – 0.9441)	23.70 (0.933)
		I.D.	20.020 – 20.041 (0.7882 – 0.7890)	20.06 (0.790)
	Output drive gear shaft O.D.	19.979 – 20.000 (0.7866 – 0.7874)	19.97 (0.786)	
	Gear-to-bushing clearance	0.020 – 0.062 (0.0008 – 0.0024)	0.082 (0.0032)	
	Gear bushing-to-shaft clearance	0.020 – 0.042 (0.0008 – 0.0017)	0.08 (0.003)	
	Output gear damper spring free length	62.3 (2.45)	59 (2.3)	
	Output drive gear backlash	0.08 – 0.23 (0.003 – 0.009)	0.40 (0.016)	
	Backlash difference between measurements	–	0.10 (0.004)	

TOEQUE VALUES

Crankcase bolt (8 mm)	23 N·m (2.3 kgf·m, 17 lbf·ft)	
Crankpin bearing cap nut	33 N·m (3.4 kgf·m, 24 lbf·ft)	Apply engine oil to the threads and seating surface
Gearshift cam plate bolt	12 N·m (1.2 kgf·m, 9 lbf·ft)	Apply locking agent to the threads
Output gear case mounting bolt	31 N·m (3.2 kgf·m, 23 lbf·ft)	Apply sealant to the threads
Output drive gear assembly mounting bolt	31 N·m (3.2 kgf·m, 23 lbf·ft)	Apply engine oil to the threads and seating surface
Output driven gear assembly mounting socket bolt	31 N·m (3.2 kgf·m, 23 lbf·ft)	Apply engine oil to the threads and seating surface
Output drive gear bearing lock nut (inner)	73 N·m (7.4 kgf·m, 54 lbf·ft)	Lock nut; replace with a new one and stake Apply engine oil to the threads and seating surface
(outer)	98 N·m (10.0 kgf·m, 72 lbf·ft)	Lock nut; replace with a new one and stake Apply engine oil to the threads and seating surface
Output driven gear bearing lock nut (inner)	73 N·m (7.4 kgf·m, 54 lbf·ft)	Lock nut; replace with a new one and stake Apply engine oil to the threads and seating surface
(outer)	98 N·m (10.0 kgf·m, 72 lbf·ft)	Lock nut; replace with a new one and stake Apply engine oil to the threads and seating surface
Output driven gear shaft bolt	49 N·m (5.0 kgf·m, 36 lbf·ft)	

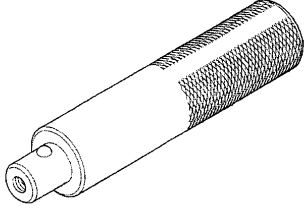
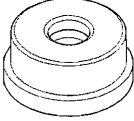
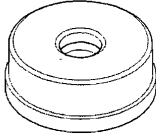
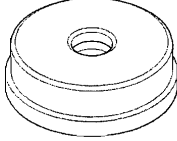
CRANKSHAFT/TRANSMISSION

TOOLS

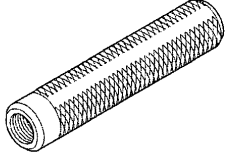
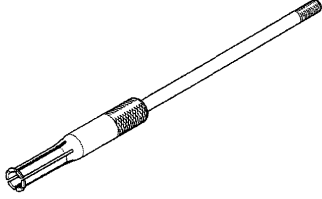
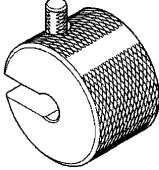
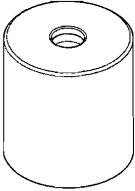
<p>Driver 07749-0010000</p> 	<p>Attachment, 42 x 47 mm 07746-0010300</p> 	<p>Attachment, 52 x 55 mm 07746-0010400</p> 
<p>Attachment, 62 x 68 mm 07746-0010500</p> 	<p>Pilot, 22 mm 07746-0041000</p> 	<p>Pilot, 17 mm 07746-0040400</p> 
<p>Pilot, 20 mm 07746-0040500</p> 	<p>Pilot, 30 mm 07746-0040700</p> 	<p>Remover handle 07936-3710100</p> 
<p>Bearing remover set, 20 mm 07936-3710600</p> 	<p>Remover weight 07741-0010201 or 07936-371020A or 07936-3710200 (U.S.A. only)</p> 	<p>Driver, 57 mm 070MF-MEG0100</p> 

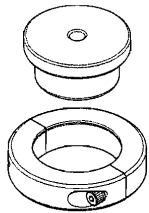
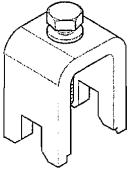
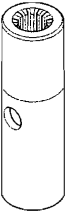
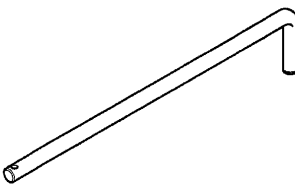
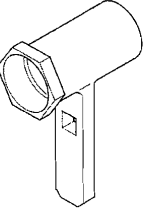
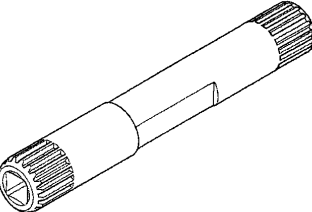
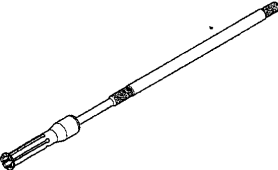
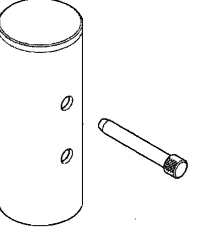
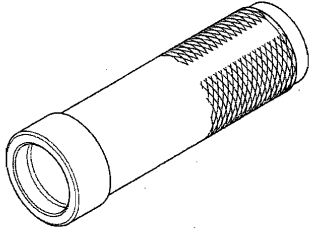
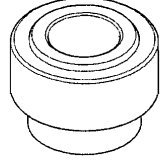
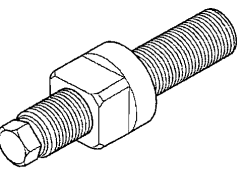
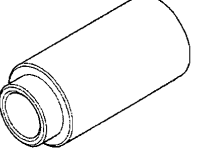
<p>Metal installer set 070MF-MEG0200</p> 	<p>Damper spring compressor 07964-ME90000</p> 	<p>Shaft holder A 07PAB-0010100</p>  <p>or 07923-6890101 (U.S.A. only)</p>
<p>Holder handle 07PAB-0010400</p> 	<p>Lock nut wrench, 36 x 47.8 mm 07916-MB00002</p> 	<p>Differential inspection tool 07KMK-HC50101</p>  <p>or 07KMK-HC5010A (U.S.A. only)</p>
<p>Bearing remover set, 17 mm 07936-3710300</p> 	<p>Oil seal driver 07965-KE80200</p> 	<p>Driver, 40 mm I.D. 07746-0030100</p> 
<p>Attachment, 30 mm I.D. 07746-0030300</p> 	<p>Assembly bolt 07965-1660200</p> 	<p>Assembly collar 07965-1660302</p>  <p>or 07965-166030A</p>

CRANKSHAFT/TRANSMISSION

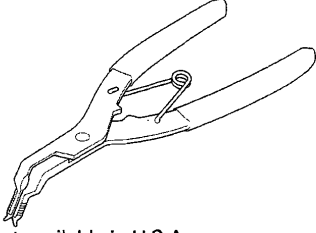
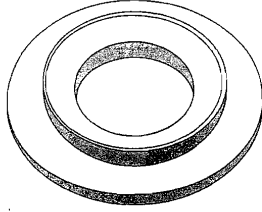
<p>Threaded adaptor 07965-KA30000</p> 	<p>Snap ring pliers 07914-5670101</p>  <p>not available in U.S.A. or 07914-5670100</p>	<p>Compressor seat 07967-9690200</p> 
---	---	--

TROUBLESHOOTING

Excessive engine noise

- Worn main journal bearings
- Worn crankpin bearings
- Worn or damaged transmission gear
- Worn or damaged transmission bearings

Excessive noise in side gear

- Worn or damaged output shaft and final drive shaft gears
- Worn or damaged output gear case bearing
- Incorrect adjusted shim

Hard to shift

- Improper clutch operation (page 11-9)
- Incorrect engine oil viscosity
- Bent shift forks
- Bent shift fork shaft
- Bent shift fork claw
- Damaged shift drum cam grooves
- Bent gearshift spindle

Transmission jumps out of gear

- Worn gear dogs or holes
- Worn gear shifter groove
- Bent shift fork shaft
- Broken shift drum stopper arm
- Worn or bent shift forks
- Broken drum stopper arm spring
- Broken gearshift spindle return spring

CRANKCASE SEPARATION

Remove the engine from the frame (page 8-4).

Refer to Service Information (page 13-3) for removal of necessary parts before separating the crankcase.

Remove the bolts and cam chain tensioner setting plates.
Remove the cam chains.

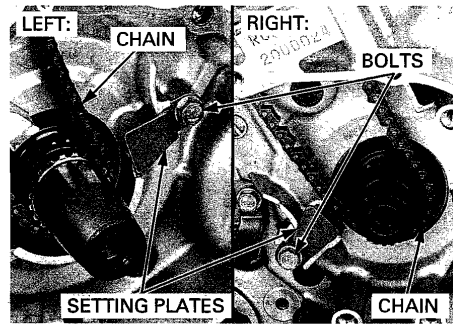

Hold the output driven gear shaft using the special tools, loosen the output drive gear shaft bolt and remove it with the washer.

TOOLS:

Shaft holder A

07PAB-0010100 or
07923-6890101

(U.S.A. only)

Holder handle

07PAB-0010400

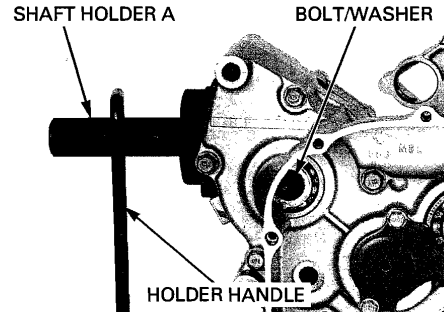

Remove the bolts and bearing setting plate.

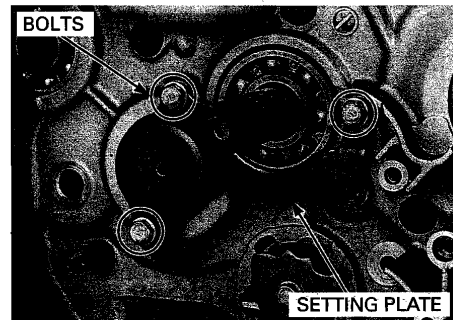

Loosen and remove the 6 mm and 8 mm bolts in a crisscross pattern in several steps.

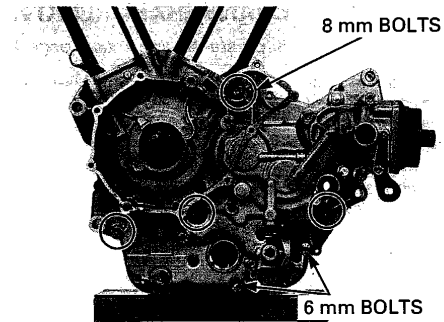

CRANKSHAFT/TRANSMISSION

Loosen and remove the 6 mm and 8 mm bolts with washer in a crisscross pattern in several steps.

Turn the shift drum until the position as shown.

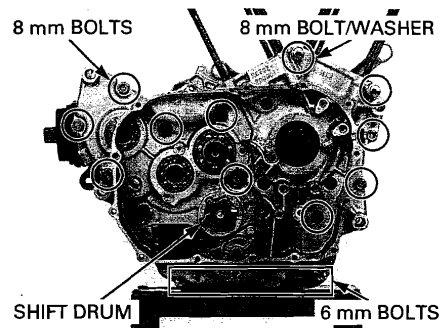

Place the crankcase with the left crankcase down and remove the right crankcase.

NOTE:

- Separate the right crankcase from the left crankcase while prying at the points as shown.
- Separate the right crankcase from the left crankcase while tapping them at several locations with a soft hammer.

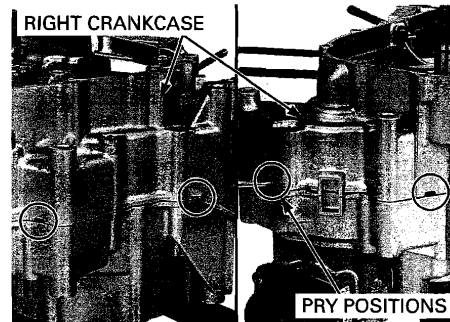

Remove the dowel pins and pipe seal.

Clean off the sealant from the left and right crankcase mating surfaces.

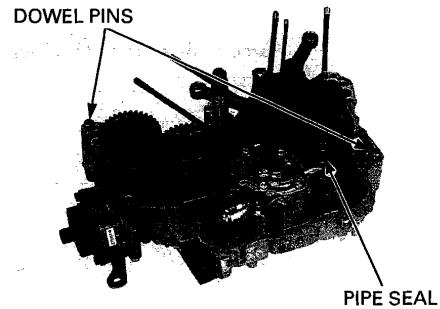

CRANKSHAFT/CONNECTING ROD

CRANKSHAFT REMOVAL

Separate the crankcase (page 13-9).

During crankshaft and connecting rod service, be careful not to damage the main journal or crankpin bearing inserts.

Remove the crankshaft/connecting rod from the left crankcase.

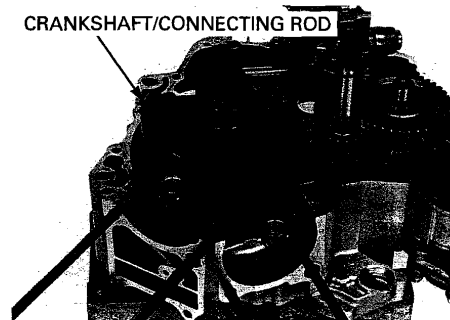

SIDE CLEARANCE INSPECTION

Before removing the connecting rods, check the big end side clearance. Measure the side clearance by inserting the feeler gauge between the crankshaft and connecting rod big end.

SERVICE LIMIT: 0.30 mm (0.012 in)

FEELER GAUGE

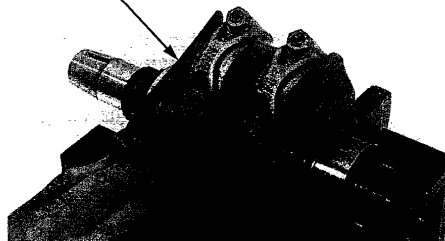

CONNECTING ROD REMOVAL

Tap the side of the cap lightly if bearing cap is hard to remove.

Remove the crankpin bearing cap nuts and the bearing caps.

CAPS

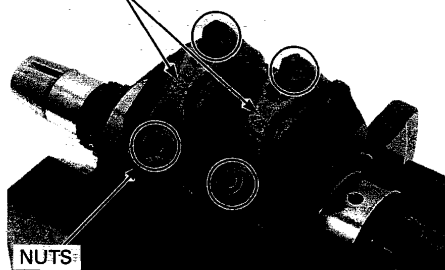

NUTS

Mark the rods, bearings and caps as you remove them to indicate the correct cylinder and position on the crankpins for reassembly.

For the connecting rod small end inspection (page 10-7).

BEARING

BEARING CAP



CONNECTING ROD

CRANKSHAFT INSPECTION

Check the crankshaft journal surfaces for damage, discoloration or scratch.

CRANKSHAFT RUNOUT

Place the crankshaft on a stand or V-blocks.
Set a dial indicator on the main journals.
Rotate the crankshaft two revolutions and read the runout.

SERVICE LIMIT: 0.03 mm (0.001 in)

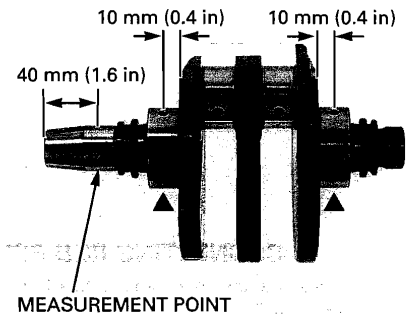

CONNECTING ROD INSTALLATION

NOTICE

Do not interchange the bearing inserts. They must be installed in their original locations or the correct bearing oil clearance may not be obtained, resulting in engine damage.

Wipe any oil from the connecting rod, cap and bearing inserts.

Install the bearing inserts on the connecting rods and caps by aligning the tab with the groove.

Apply molybdenum disulfide oil to the thrust surface of the crankpin bearings.

Install the rods and caps on the crankshaft by aligning the I.D. code on the rod and cap. Be sure each part is installed in its original position, as noted during removal.

NOTE:

- Face the oil jet of front cylinder connecting rod to rearward (intake side) of the cylinder.
- Face the oil jet of rear cylinder connecting rod to rearward (exhaust side) of the cylinder.

Apply engine oil to the bearing cap nut threads and seating surface, then tighten them in several steps alternately.

TORQUE: 33 N·m (3.4 kgf·m, 24 lbf·ft)

After tightening the nuts, check that the connecting rods move freely without binding.

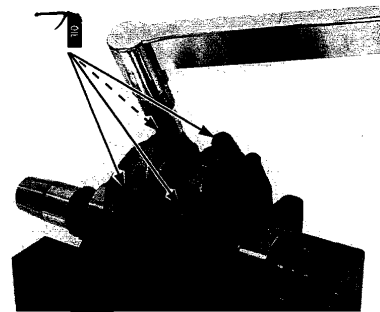
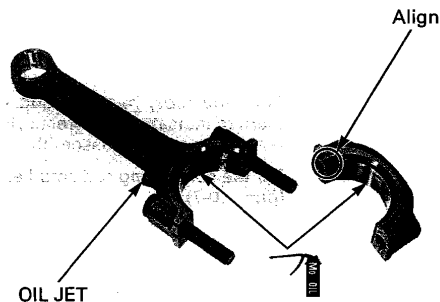

CRANKSHAFT INSTALLATION

Apply molybdenum disulfide oil to the crankshaft main journals and install the crankshaft into the left crankcase.

Assemble the crankcase (page 13-49).

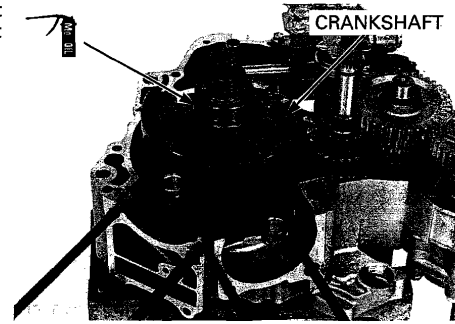
**CRANKPIN BEARING****NOTICE**

Do not interchange the bearing inserts. They must be installed in their original locations or the correct bearing oil clearance may not be obtained, resulting in engine damage.

Remove the connecting rod (page 13-11).

BEARING INSPECTION

Check the bearing inserts for unusual wear, damage or peeling and replace them if necessary.

Select the replacement bearing (page 13-14).

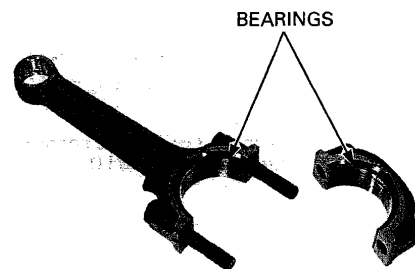
**OIL CLEARANCE INSPECTION**

Clean off any oil from the bearing inserts and crankpins.

Put a strip of plastigauge lengthwise on each crankpin avoiding the oil hole.

Carefully install the connecting rods and bearing caps on the correct crankpins.

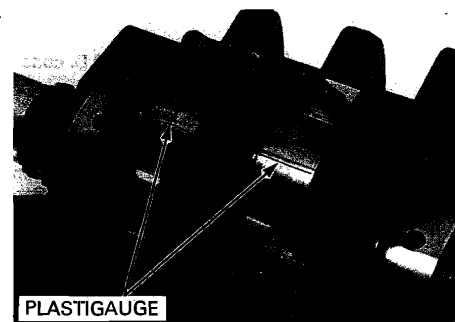

CRANKSHAFT/TRANSMISSION

Do not rotate the crankshaft during inspection.

Apply engine oil to the threads and seating surfaces of the bearing cap nuts. Install the nuts and tighten them evenly.

TORQUE: 33 N·m (3.4 kgf·m, 24 lbf·ft)

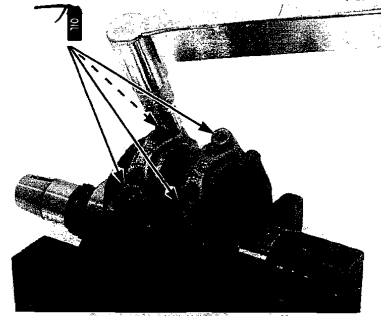

Remove the bearing caps and measure the compressed plastigauge at its widest point on each crankpin to determine the oil clearance.

SERVICE LIMIT: 0.07 mm (0.003 in)

If the clearance exceeds the service limit, select the correct replacement bearings as follows.

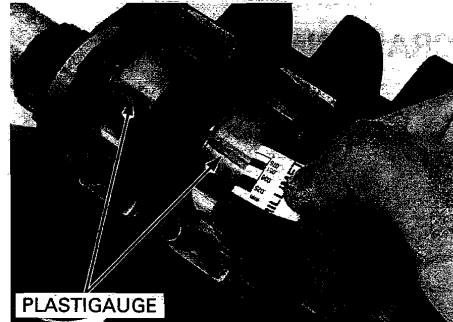

BEARING SELECTION

Record the connecting rod I.D. code number.

NOTE:

Number 3 or 4 on the connecting rod is the code for the connecting rod I.D.



CONNECTING ROD I.D. CODE NUMBER

Record the crankpin O.D. code letter.

NOTE:

Letters A or B on each crank weight is the code for the crankpin O.D.

Cross reference the connecting rod and crankpin codes to determine the replacement bearing color code.

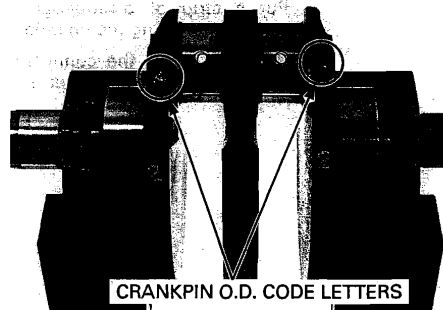

CRANKPIN O.D. CODE LETTERS

CRANKPIN BEARING SELECTION TABLE:

			CONNECTING ROD I.D. CODE	
			3	4
			43.000 – 43.008 mm (1.6929 – 1.6932 in)	43.008 – 43.016 mm (1.6932 – 1.6935 in)
CRANKPIN O.D. CODE	A	39.982 – 39.990 mm (1.5741 – 1.5744 in)	C (Pink)	B (Yellow)
	B	39.974 – 39.982 mm (1.5738 – 1.5741 in)	B (Yellow)	A (Green)

BEARING THICKNESS:

- A (Green): Thick
- B (Yellow): †
- C (Pink): Thin

NOTICE

After selecting new bearings, recheck the clearance with a plastigauge. Incorrect clearance can cause severe engine damage.

IDENTIFICATION COLOR

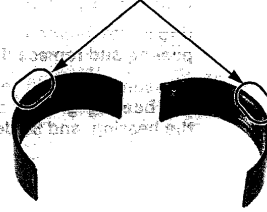

CONNECTING ROD SELECTION

An alphabetical weight code is stamped on the cap. If a connecting rod requires replacement, you should select a rod with the same weight code as the original. But if that is unavailable, you may use one of the others specified in the following chart.

CONNECTING ROD WEIGHT COMBINATION TABLE:

- The "O" mark in the table indicated that matching is possible in the crossed codes.

		REAR WEIGHT CODE		
		A	B	C
FRONT WEIGHT CODE	A		○	○
	B	○	○	○
	C	○	○	

		WEIGHT	
CONNECTING ROD WEIGHT CODE	A	398 – 403 g (14.0 – 14.2 oz)	
	B	403 – 408 g (14.2 – 14.4 oz)	
	C	408 – 413 g (14.4 – 14.6 oz)	

Install the following:

- Connecting rod (page 13-12)
- Crankshaft (page 13-13)



WEIGHT CODE

MAIN JOURNAL BEARING

NOTICE

Do not interchange the bearing inserts. They must be installed in their original locations or the correct bearing oil clearance may not be obtained, resulting in engine damage.

Remove the crankshaft (page 13-10).

BEARING INSPECTION

Clean off any oil from the bearings.

Check the bearings for unusual wear, damage or peeling and replace them if necessary.

Measure the main journal bearing I.D. at between the bearing groove and crankcase outside end of the bearing, and 90 degrees to the index mark.

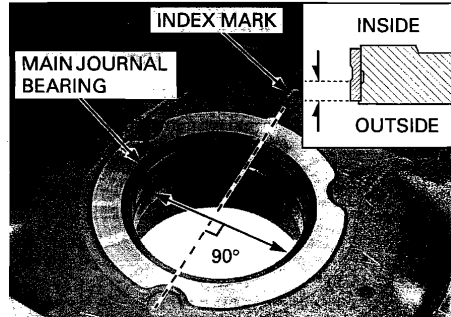

Clean off any oil from the crankshaft journals.

Measure and record the crankshaft main journal O.D.

SERVICE LIMIT: 52.976 mm (2.0857 in)

Calculate the main journal oil clearance.

SERVICE LIMIT: 0.07 mm (0.003 in)

If the clearance exceeds the service limit, select the bearing.

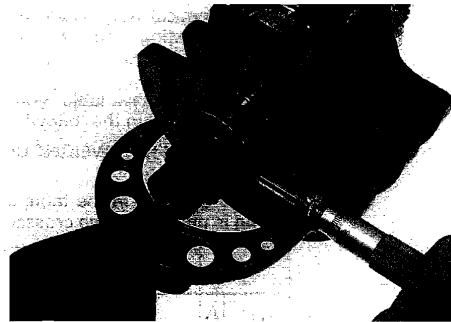

BEARING SELECTION

Set a special tool and hydraulic press on the outside of the crankcase.

TOOL:

Driver, 57 mm

070MF-MEG0100

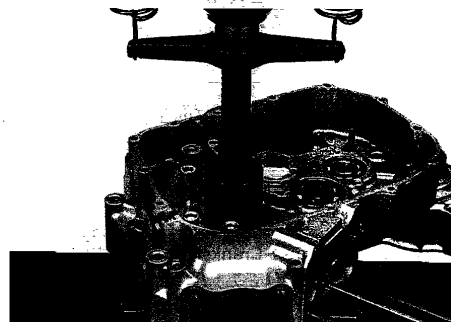

Press the main journal bearings toward the inside of the crankcase.

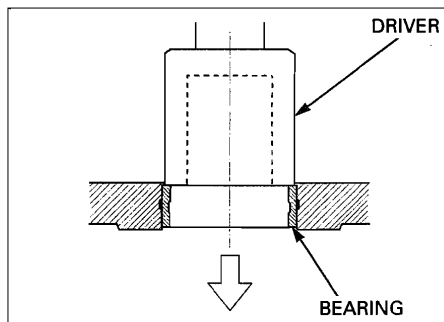

Measure and record the crankcase main journal I.D. at between the main journal groove and crankcase outside end, and 90 degrees to the index mark.

SERVICE LIMIT: 58.070 mm (2.2862 in)

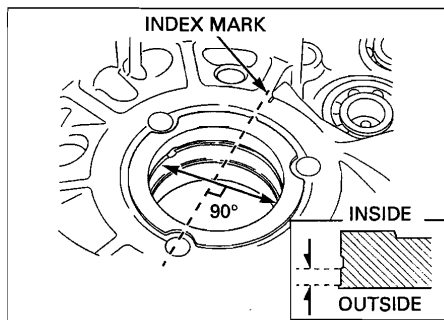

Depending upon the results of the above measurements there are four possible scenarios for main journal bearing selection:

- Crankshaft and crankcase are replaced
- Crankcase only is replaced
- Crankshaft only is replaced
- Main journal bearings only are replaced

Carefully refer to the following instructions and tables for main journal bearing selection.

Record the bearing support I.D. code letter.

NOTE:

Letters A or B on each crankcase is the code for the crankcase I.D.

Record the main journal O.D. code number.

NOTE:

Letters 1, 2 or 3 on each crank weight is the code for crankshaft journal O.D.

Cross-reference the crankshaft and crankcase codes to determine the replacement bearing color.

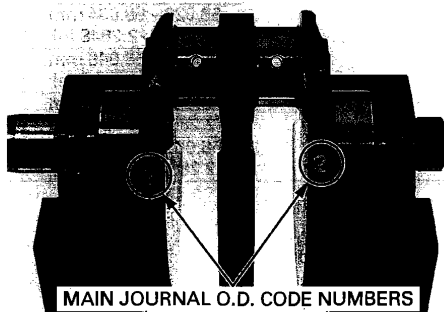
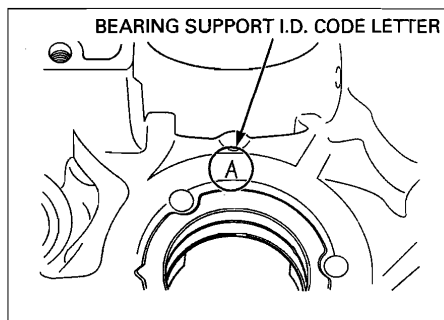

CRANKSHAFT/TRANSMISSION

In case the crankshaft and crankcase are replaced:

			MAIN JOURNAL O.D. CODE		
			1	2	3
			52.994 – 53.000 mm (2.0864 – 2.0866 in)	52.988 – 52.994 mm (2.0861 – 2.0864 in)	52.982 – 52.988 mm (2.0859 – 2.0861 in)
BEARING SUPPORT I.D. CODE	A	58.016 – 58.022 mm (2.2841 – 2.2843 in)	C (Brown)	B (Black)	A (Blue)
	B	58.010 – 58.016 mm (2.2839 – 2.2841 in)	D (Green)	C (Brown)	B (Black)

In case the crankcase only is replaced:

			MAIN JOURNAL O.D.			
			52.994 – 53.000 mm (2.0864 – 2.0866 in)	52.988 – 52.994 mm (2.0861 – 2.0864 in)	52.982 – 52.988 mm (2.0859 – 2.0861 in)	52.976 – 52.982 mm (2.0857 – 2.0859 in)
BEARING SUPPORT I.D. CODE	A	58.016 – 58.022 mm (2.2841 – 2.2843 in)	C (Brown)	B (Black)	A (Blue)	A (Blue)
	B	58.010 – 58.016 mm (2.2839 – 2.2841 in)	D (Green)	C (Brown)	B (Black)	A (Blue)

In case the crankshaft only is replaced:

		MAIN JOURNAL O.D. CODE		
		1	2	3
		52.994 – 53.000 mm (2.0864 – 2.0866 in)	52.988 – 52.994 mm (2.0861 – 2.0864 in)	52.982 – 52.988 mm (2.0859 – 2.0861 in)
MAIN JOURNAL I.D.	58.010 – 58.016 mm (2.2839 – 2.2841 in)	D (Green)	C (Brown)	B (Black)
	58.016 – 58.022 mm (2.2841 – 2.2843 in)	C (Brown)	B (Black)	A (Blue)
	58.022 – 58.034 mm (2.2843 – 2.2848 in)	B (Black)	A (Blue)	A (Blue)
	58.034 – 58.046 mm (2.2848 – 2.2853 in)	A (Blue)	O.S. G (Red)	O.S. G (Red)
	58.046 – 58.058 mm (2.2853 – 2.2857 in)	O.S. G (Red)	O.S. F (Pink)	O.S. F (Pink)
	58.058 – 58.070 mm (2.2857 – 2.2862 in)	O.S. F (Pink)	O.S. E (Yellow)	O.S. E (Yellow)

In case of main bearing replacement only:

		MAIN JOURNAL O.D.			
		52.994 – 53.000 mm (2.0864 – 2.0866 in)	52.988 – 52.994 mm (2.0861 – 2.0864 in)	52.982 – 52.988 mm (2.0859 – 2.0861 in)	52.976 – 52.982 mm (2.0857 – 2.0859 in)
BEARING SUPPORT I.D.	58.010 – 58.016 mm (2.2839 – 2.2841 in)	D (Green)	C (Brown)	B (Black)	A (Blue)
	58.016 – 58.022 mm (2.2841 – 2.2843 in)	C (Brown)	B (Black)	A (Blue)	A (Blue)
	58.022 – 58.034 mm (2.2843 – 2.2848 in)	B (Black)	A (Blue)	A (Blue)	O.S. G (Red)
	58.034 – 58.046 mm (2.2848 – 2.2853 in)	A (Blue)	O.S. G (Red)	O.S. G (Red)	O.S. F (Pink)
	58.046 – 58.058 mm (2.2853 – 2.2857 in)	O.S. G (Red)	O.S. F (Pink)	O.S. F (Pink)	O.S. E (Yellow)
	58.058 – 58.070 mm (2.2857 – 2.2862 in)	O.S. F (Pink)	O.S. E (Yellow)	O.S. E (Yellow)	O.S. E (Yellow)

BEARING THICKNESS:

- O.S. E (Yellow): Thick
- O.S. F (Pink):
- O.S. G (Red): ↑
- A (Blue): Middle
- B (Black):
- C (Brown): ↓
- D (Green): Thin

IDENTIFICATION COLOR

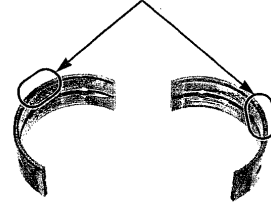

BEARING INSTALLATION

Apply engine oil to new bearing surface.
Set new bearings to the metal installer aligning its side edge with the metal installer grooves.

TOOL:

Metal installer set **070MF-MEG0200**

Tighten the bolts alternately in several steps to the specified torque.

TORQUE: 23 N-m (2.3 kgf-m, 17 lbf-ft)

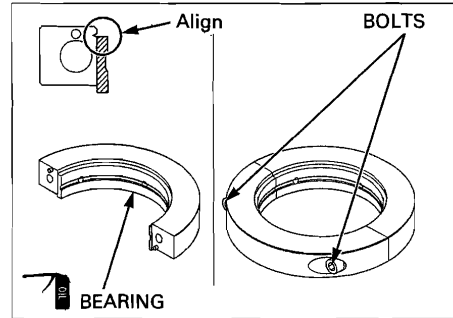

Set the bearings and special tools assembly on inside of the crankcase, fitting the bearing edge in the crankcase main journal.
Align the mating line of the bearings with the index mark on the crankcase as shown.

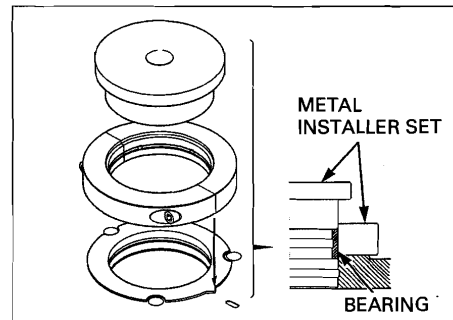

Set the hydraulic press.

TOOL:

Metal installer set **070MF-MEG0200**

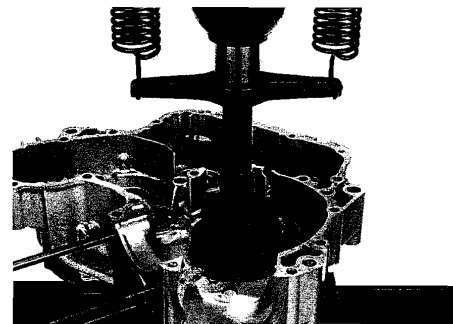

CRANKSHAFT/TRANSMISSION

Press the new bearings until the metal installer flange fully seated.

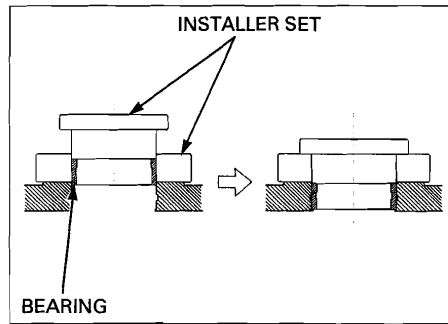

Make sure the bearing mating line aligns with the index mark on the crankcase.

Check the oil clearance (page 13-16).

- After selecting new bearings, recheck the clearance. Incorrect clearance can cause severe engine damage.

Install the crankshaft (page 13-13).

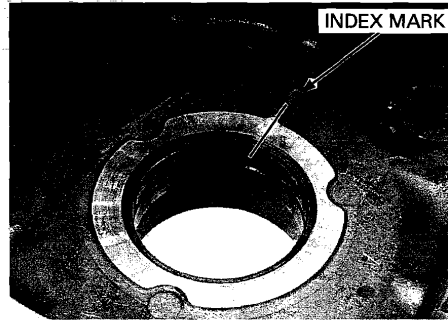

TRANSMISSION

REMOVAL

Separate the crankcase (page 13-9).

Remove the fork shaft from the shift forks.

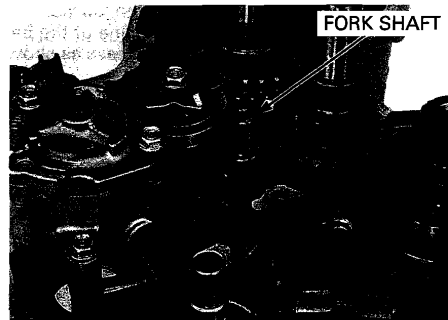

Remove the shift forks and shift drum.

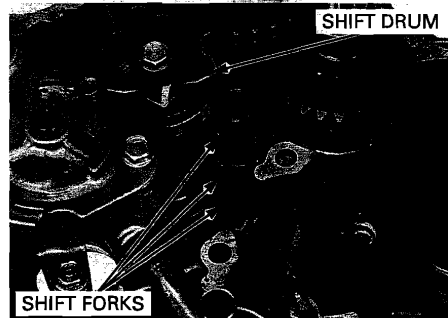

Remove the mainshaft and countershaft together.

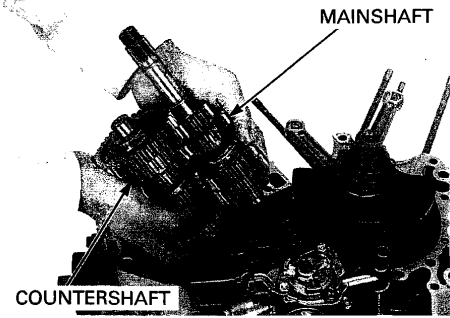

TRANSMISSION DISASSEMBLY

Disassemble the mainshaft and countershaft.

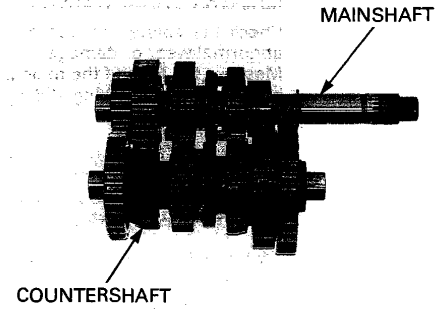

INSPECTION

GEARS

Check the gear dogs, dog slots and teeth for damage or excessive wear.

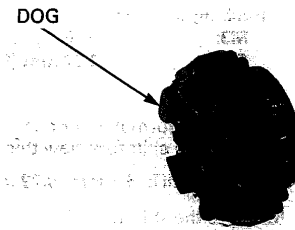

Measure the I.D. of each gear.

SERVICE LIMITS:

- M3, M5 gears:** 28.04 mm (1.104 in)
- C1, C4 gears:** 31.05 mm (1.222 in)
- C2 gear:** 24.04 mm (0.946 in)

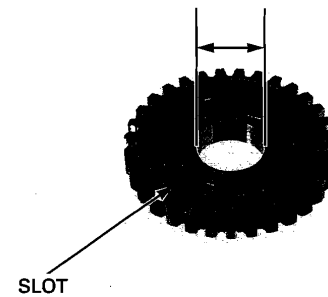

BUSHINGS

Check the bushings for wear or damage.
Measure the O.D. of each bushing.

SERVICE LIMITS:

M3, M5, gear bushings: 27.94 mm (1.100 in)
C1, C4 gear bushings: 30.93 mm (1.218 in)
C2 gear bushing: 23.94 mm (0.943 in)

Measure the I.D. of each bushing.

SERVICE LIMITS:

M3 gear bushing: 25.04 mm (0.986 in)
C2 gear bushing: 20.04 mm (0.789 in)

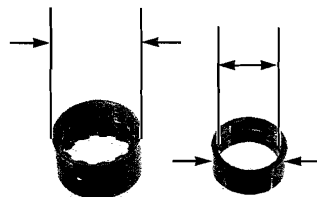

MAINSHAFT/COUNTERSHAFT

Check the spline grooves and sliding surfaces for abnormal wear or damage.
Measure the O.D. of the mainshaft and countershaft at the gear and bushing sliding areas.

SERVICE LIMITS:

Mainshaft (at M3 gear bushing):
24.94 mm (0.982 in)
Countershaft (at C2 gear bushing):
19.96 mm (0.786 in)

Calculate the gear-to-bushing and bushing-to-shaft clearance.

SERVICE LIMITS:

Gear-to-bushing
M3, M5, C2: 0.10 mm (0.004 in)
C1, C4: 0.11 mm (0.004 in)
Bushing-to-shaft
M3: 0.10 mm (0.004 in)
C2: 0.07 mm (0.003 in)

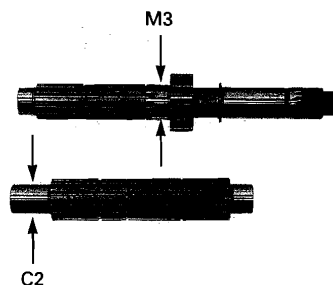

SHIFT FORK

Check for deformation or abnormal wear.
Measure the shift fork claw thickness.

SERVICE LIMIT: 5.6 mm (0.22 in)

Measure the shift fork I.D.

SERVICE LIMIT: 13.03 mm (0.513 in)

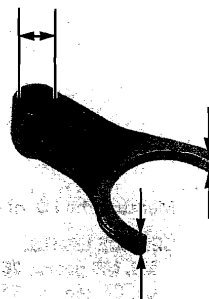

SHIFT FORK SHAFT

Check the shift fork shaft for bend, abnormal wear or damage.
Measure the shift fork shaft O.D.

SERVICE LIMIT: 12.90 mm (0.508 in)

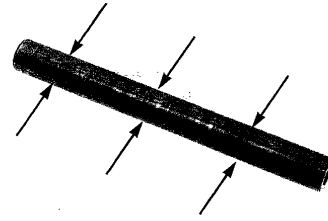

SHIFT DRUM/SHIFT DRUM BEARING

Remove the bolt and gearshift cam plate.

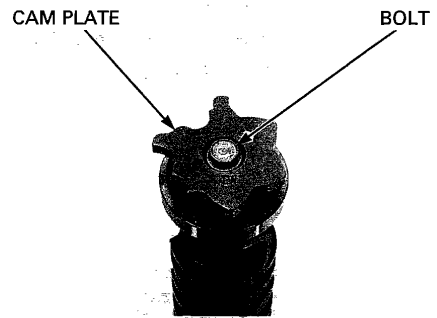

Remove the dowel pin and bearing.

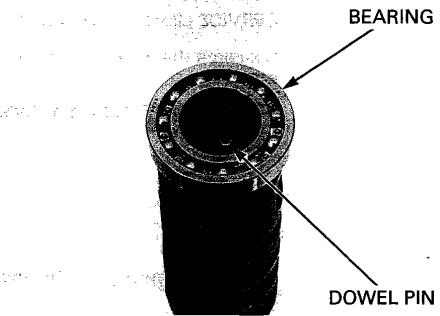

Remove the dowel pins from the gearshift cam plate.

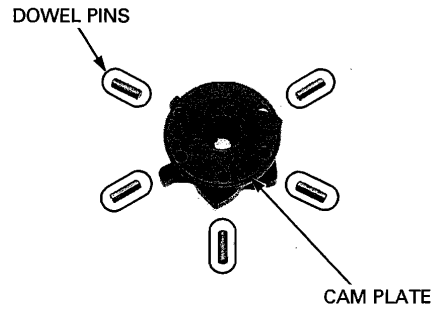

CRANKSHAFT/TRANSMISSION

Temporarily install the bearing on the shift drum.
Turn the outer race of the bearing with your finger.
The bearing should turn smoothly and quietly.

Also check that the bearing inner race fits tightly on the shift drum.

Remove and discard the bearing if the races do not turn smoothly, quietly, or if it fits loosely on the shift drum.

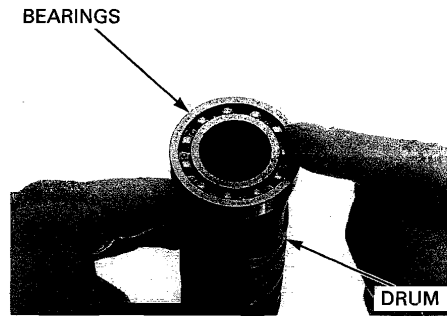

Check the shift drum end for scoring, scratches, or evidence of insufficient lubrication.
Check the shift drum grooves for abnormal wear or damage.

Measure the shift drum O.D. at left end.

SERVICE LIMIT: 11.94 mm (0.470 in)

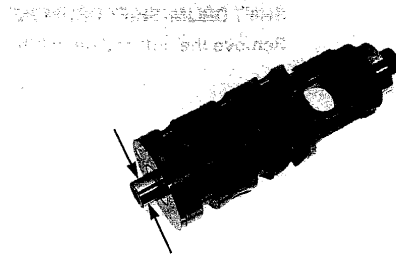

Check the shift drum journal in the left crankcase for excessive wear or damage.
Measure the shift drum journal I.D.

SERVICE LIMIT: 12.05 mm (0.474 in)

Calculate the shift drum-to-shift drum journal clearance.

SERVICE LIMIT: 0.09 mm (0.035 in)

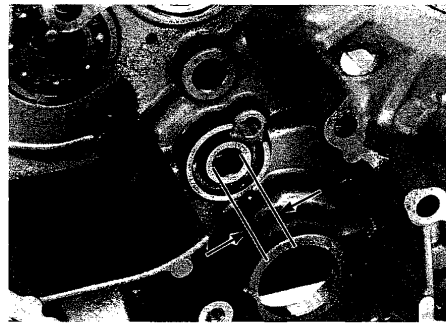

Install the dowel pins into the gearshift cam plate holes.

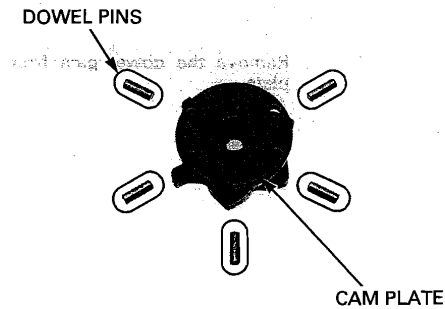

Install the bearing on the shift drum.
Install the dowel pin into the shift drum hole.

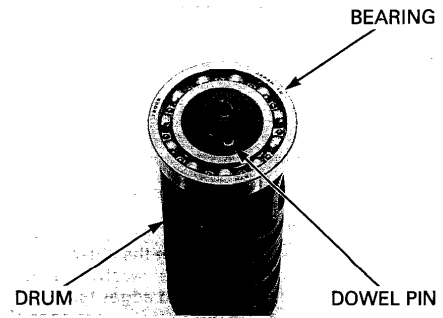

Install the gearshift cam plate by aligning its hole with the dowel pin.

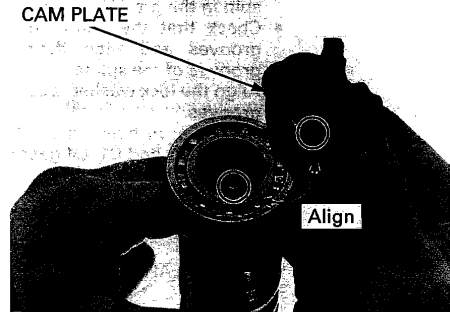

Clean and apply a locking agent to the gearshift cam plate bolt (page 1-19).
Install and tighten the bolt to the specified torque.
TORQUE: 12 N·m (1.2 kgf·m, 9 lbf·ft)

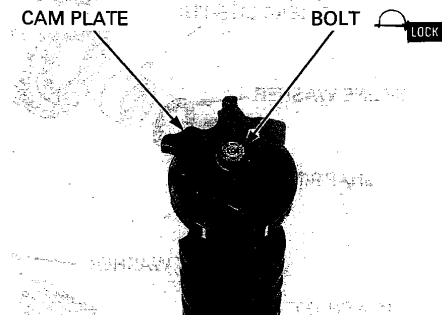

TRANSMISSION ASSEMBLY

Clean all parts in solvent.

Apply engine oil to the all gear teeth.

Apply molybdenum disulfide oil to the gear bushing sliding surface and shift fork grooves to ensure initial lubrication.

Assemble all parts into their original positions.

NOTE:

- Check the gears for freedom of movement or rotation on the shaft.
- Install the washers and snap rings with the chamfered edges facing the thrust load side.
- Do not reuse a worn snap ring which could easily spin in the groove.
- Check that the snap rings are seated in the grooves and align their end gaps with the grooves of the spline.
- Align the lock washer tabs with the spline washer grooves.
- Align the oil holes in the M5 gear bushing and mainshaft, and C1, C4 gear bushing and counter-shaft.

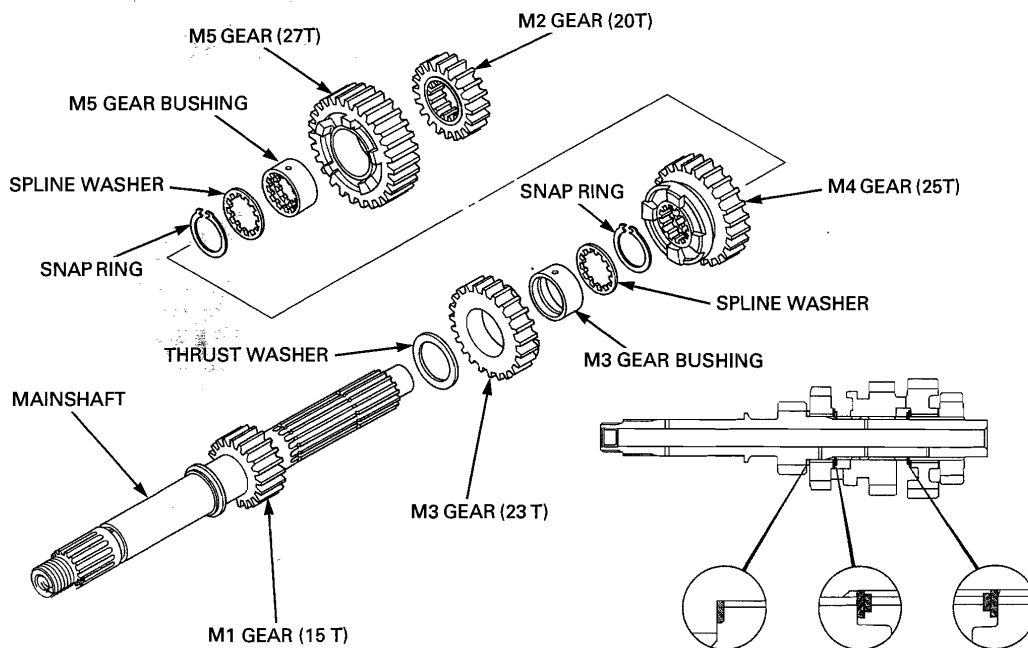
MAINSHAFT

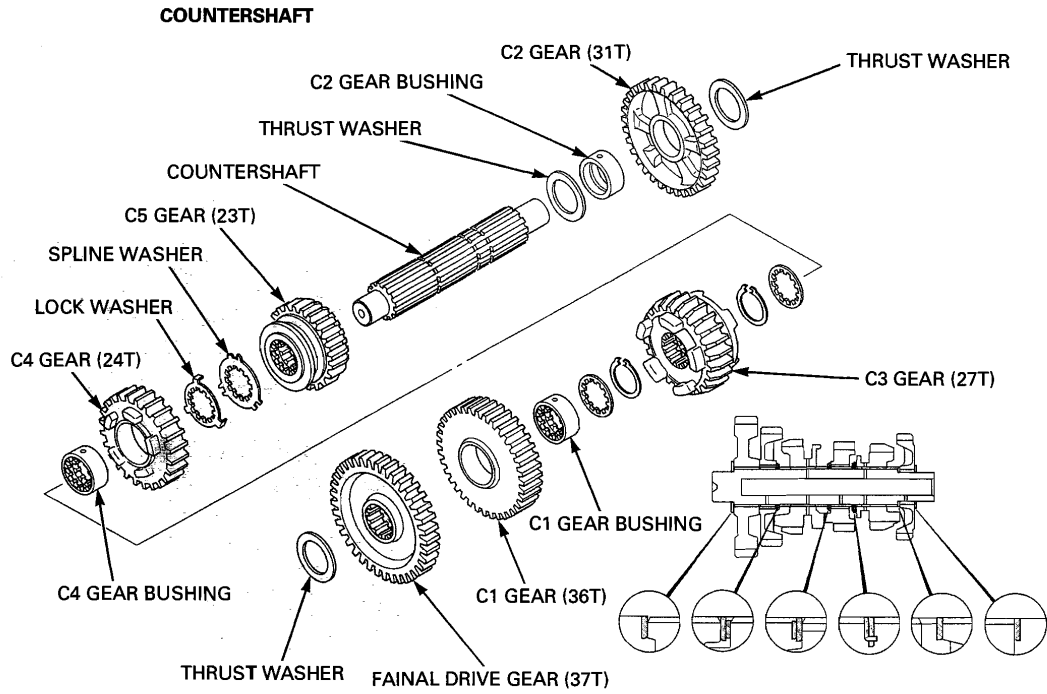

INSTALLATION

Install the mainshaft and countershaft together into the left crankcase.

Be sure to install the thrust washers of the countershaft both ends.

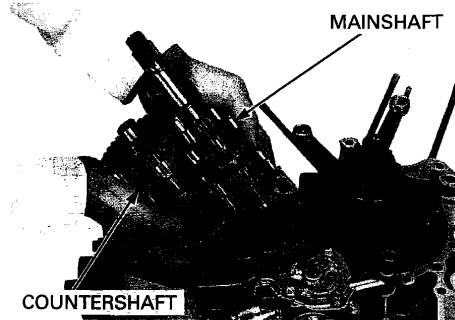

The shift forks have the following identification marks.

- "L": Left shift fork
- "C": Center shift fork
- "R": Right shift fork

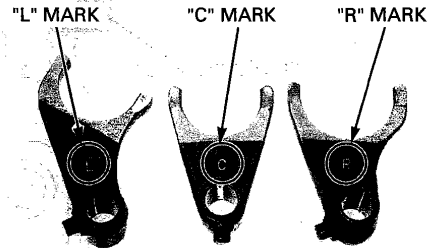

CRANKSHAFT/TRANSMISSION

Install the shift forks into the shifter gear grooves with the markings facing up (right crankcase side). Install the shift drum by aligning the shift fork guide pins with the shift drum guide grooves.

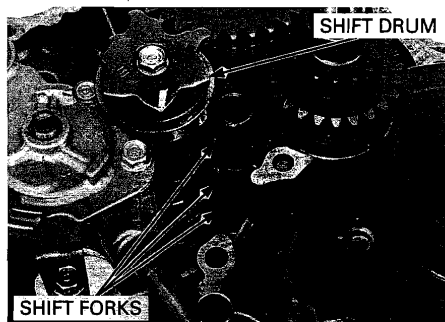

Apply engine oil to the shift fork shaft whole surface.

Insert the shift fork shaft through the shift forks into the right crankcase.

After installation, check for smooth transmission operation.

Assemble the crankcase (page 13-49).

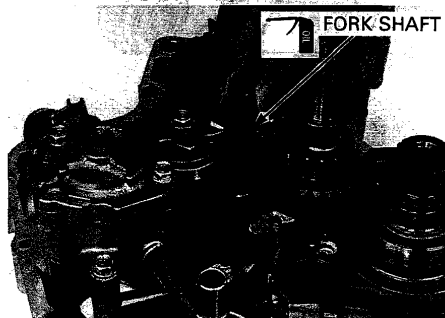

OUTPUT GEAR

Description of the output gear assembly:

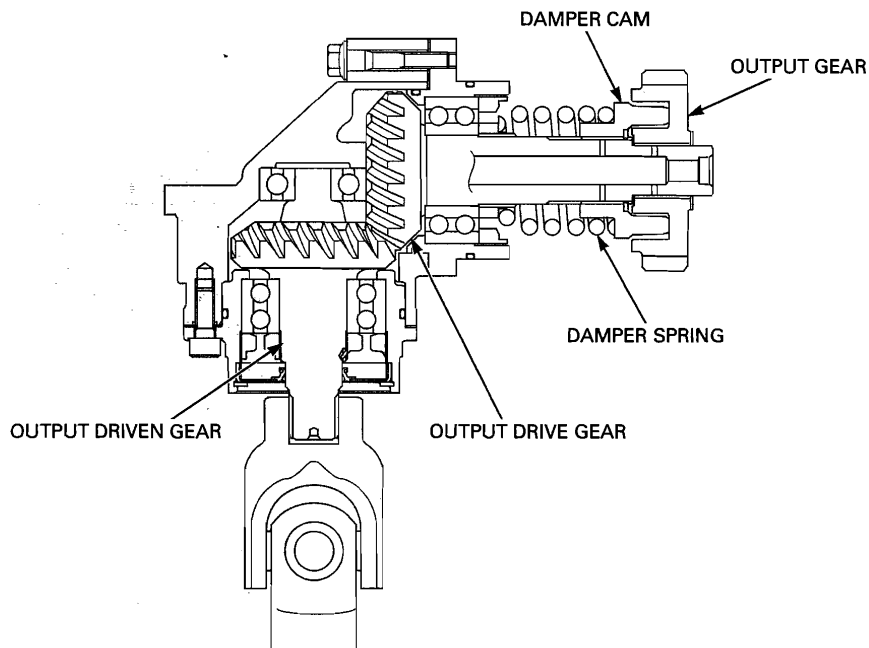

REMOVAL

Separate the crankcase (page 13-9).

Remove the following:

- Crankshaft (page 13-10)
- Transmission (page 13-20)

Remove the thrust washer and output gear.

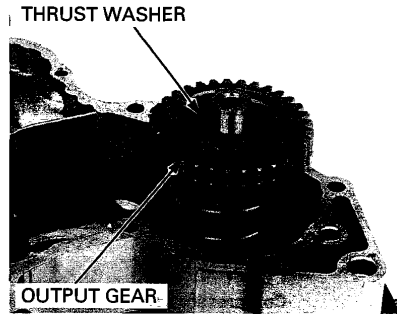

Remove the bushing from the output drive gear shaft.

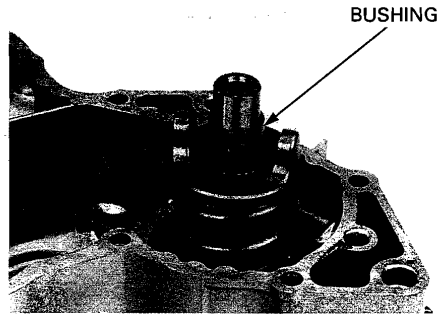

(Except U.S.A.)

Set the damper spring compressor onto the damper cam and output drive gear shaft.

Compress the damper spring by turning the compressor bolt clockwise until the snap ring can be removed.

TOOL:

Damper spring compressor 07964-ME90000

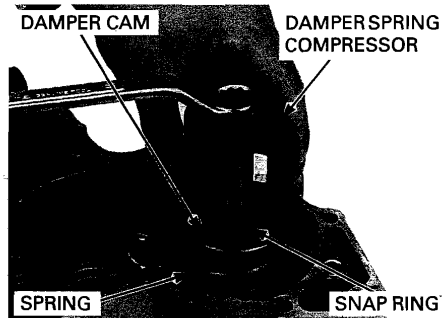

CRANKSHAFT/TRANSMISSION

(U.S.A. only)

Place the threaded adaptor in the end of the output drive gear shaft and tighten the adaptor. Place the compressor seat over the threaded adaptor with the stepped side facing upward. Install the assembly bolt through the assembly collar and attach it to the threaded adaptor. Center the compressor seat with the damper cam then begin to tighten the 23 mm nut of the assembly bolt until the snap ring is visible so it can be removed.

TOOLS:

Assembly bolt
Assembly collar

07965-1660200
07965-166030A or
07965-1660302
07967-9690200
07965-KA30000
07914-5670101 not
available in U.S.A.
or
07914-5670100

Compressor seat
Threaded adaptor
Snap ring pliers

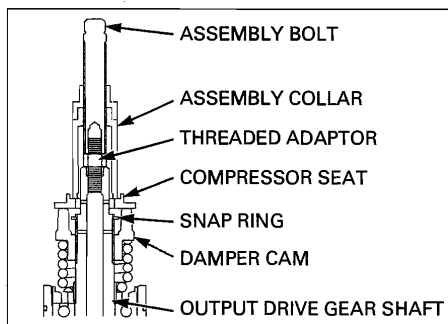

Remove the snap ring, special tools, damper cam and spring from the drive gear shaft.

Remove the bolt and stay.

Remove the output gear case mounting bolts.

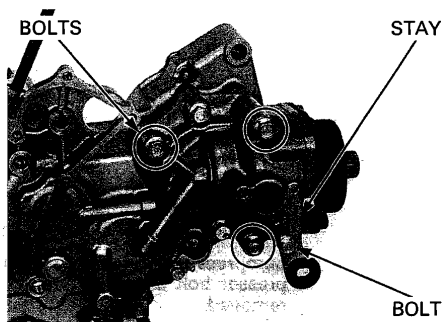

Remove the output gear case assembly and O-ring.

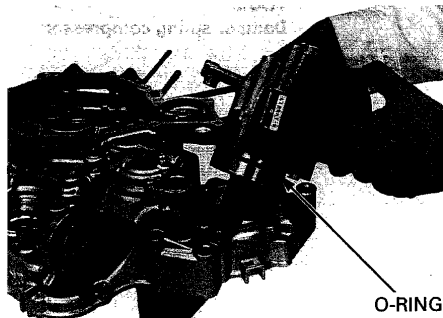

Remove the orifice and O-rings.
 Check the orifice for clog or damage.
 Replace it if necessary.

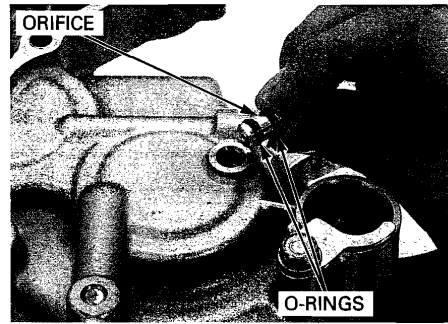

INSPECTION

DAMPER CAM

Check the projections of damper cam for damage or excessive wear.

PROJECTIONS

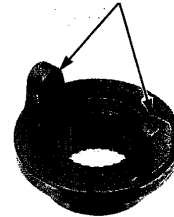

OUTPUT GEAR

Check the output gear teeth for damage or excessive wear, and the gear dog holes for damage.

Measure the output gear I.D.

SERVICE LIMIT: 24.04 mm (0.946 in)

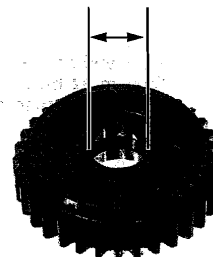

BUSHING

Check the output gear bushing for wear or damage.
 Measure the bushing I.D. and O.D.

SERVICE LIMIT: O.D. 23.70 mm (0.933 in)
I.D. 20.06 mm (0.790 in)

Calculate the output gear-to-bushing clearance.

SERVICE LIMIT: 0.082 mm (0.0032 in)

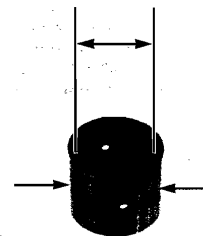

CRANKSHAFT/TRANSMISSION

OUTPUT DRIVE GEAR SHAFT

Measure the O.D. of the output drive gear shaft at the bushing sliding area.

SERVICE LIMIT: 19.97 mm (0.786 in)

Calculate the bushing-to-shaft clearance.

SERVICE LIMIT: 0.08 mm (0.003 in)

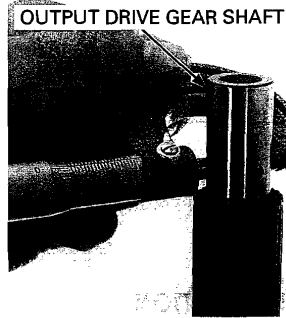

DAMPER SPRING

Measure the damper spring free length.

SERVICE LIMIT: 59 mm (2.3 in)

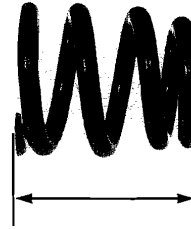

Turn the output drive gear shaft and check that the output drive and driven gear shafts turn smoothly and quietly without binding.

If the shafts do not turn smoothly or quietly, the gears and/or bearing may be damaged or faulty. They must be checked after disassembly; replace faulty parts/assemblies as required.

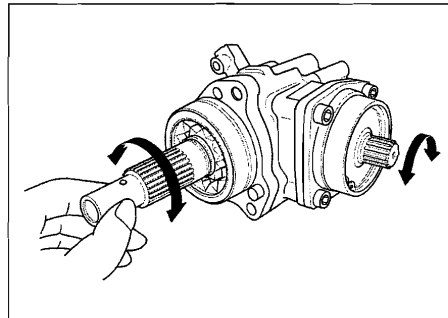

BACKLASH INSPECTION/GEAR TOOTH CONTACT PATTERN CHECK

NOTE:

Perform the backlash inspection and contact pattern check whenever you replace the output driven/drive gears, bearings, bearing holder and gear case. The extension lines from the gear engagement surfaces should intersect at one point.

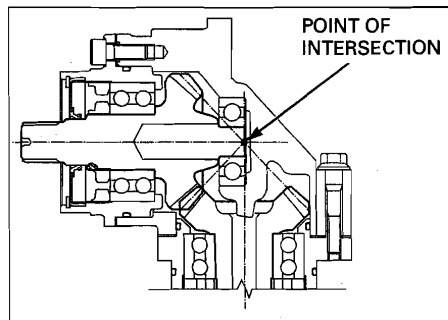

BACKLASH INSPECTION

Set the output gear case in a vise with soft jaws.

Set a horizontal type dial indicator on the output driven gear, through the VS sensor hole. Hold the output drive gear shaft with your hand and rotate the driven gear shaft until gear slack is taken up.

Turn the driven gear shaft back and forth to read backlash.

STANDARD: 0.08 – 0.23 mm (0.003 – 0.009 in)
SERVICE LIMIT: 0.40 mm (0.016 in)

Remove the dial indicator. Turn the driven gear shaft 120° and measure backlash. Repeat this procedure once more.

Compare the difference of the three measurements.

Backlash difference between measurements
SERVICE LIMIT: 0.10 mm (0.004 in)

If the difference in measurements exceeds the service limit, it indicates that the bearing is not installed squarely or the case is deformed. Inspect the bearings and case.

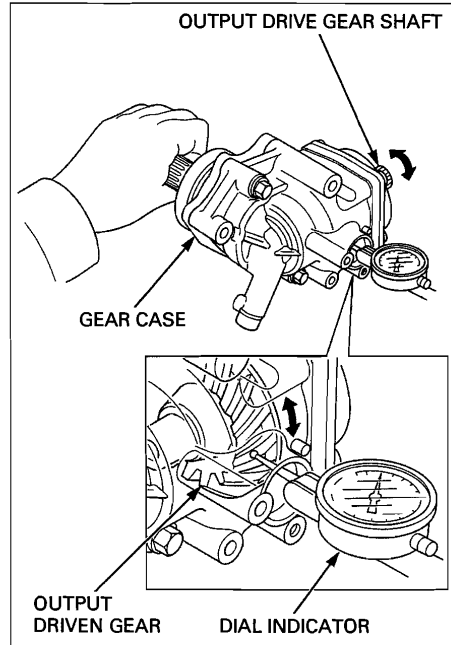

If the backlash is excessive, replace the output drive gear shim with a thinner one.

If the backlash is too small, replace the output drive gear shim with a thicker one.

Backlash is changed by about 0.06 – 0.07 mm (0.002 – 0.003 in) when shim thickness is changed by 0.10 mm (0.004 in).

OUTPUT DRIVE GEAR SHIMS:

- 0.30 mm (0.012 in)
- 0.35 mm (0.014 in)
- 0.40 mm (0.016 in)
- 0.45 mm (0.018 in)
- 0.50 mm (0.020 in) – Standard
- 0.55 mm (0.022 in)
- 0.60 mm (0.024 in)
- 0.65 mm (0.026 in)
- 0.70 mm (0.028 in)
- 0.75 mm (0.030 in)

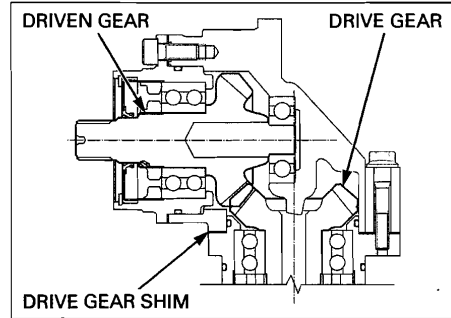

OUTPUT DRIVE GEAR SHIM REPLACEMENT

Remove the bolts and drive gear assembly from the gear case.

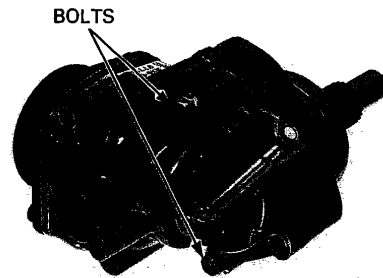

CRANKSHAFT/TRANSMISSION

Remove the dowel pin, shim and O-ring from the bearing holder.

Select the replacement shim (page 13-33).

Coat a new O-ring with engine oil and install it into the bearing holder groove.

Install the dowel pin and shim.

Install the drive gear assembly into the gear case and tighten the bolts (page 13-44).

Recheck the backlash (page 13-32).

After backlash adjustment has been made, check the gear tooth contact pattern as described below.

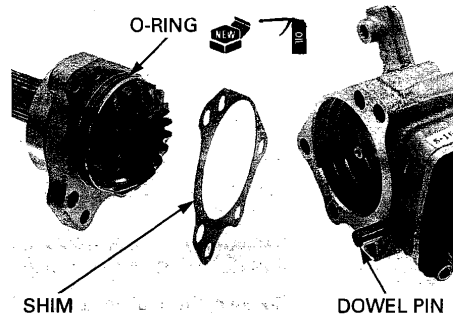

GEAR TOOTH CONTACT PATTERN CHECK

Description of the tooth:

COAST SIDE

(contacts when engine brake is applied)

TOE (inside of gear)

HEEL (out side of gear)

DRIVE SIDE

(contacts when engine power is applied)

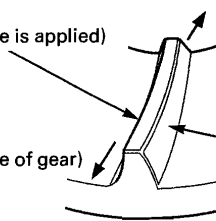

Remove the drive gear assembly from the gear case (page 13-33).

Apply a thin coat of Prussian Blue to the output driven gear teeth.

Reinstall the drive gear with the shim.

Rotate the drive gear shaft several times in the normal direction of rotation.

Remove the drive gear assembly and check the gear tooth contact pattern.

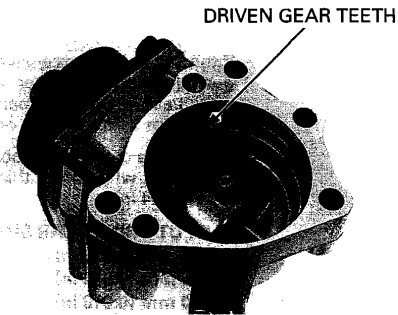

Contact is normal if Prussian Blue is transferred to the approximate center of each tooth and slightly to the toe.

If the pattern is not correct, remove and replace the output driven gear shim.

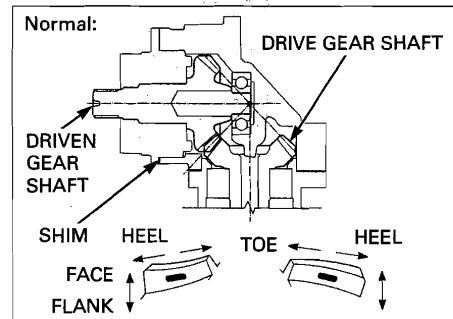

Replace the shim with a thinner one if the contact pattern is too high, toward the face.

Too high:

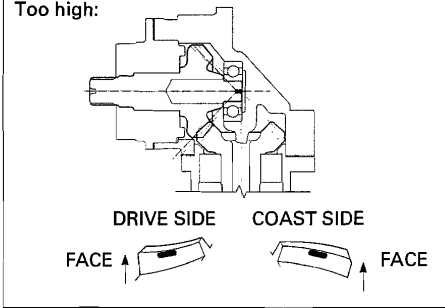

Replace the shim with a thicker one if the contact pattern is too low, toward the flank.

The pattern will shift about 1.5 – 2.0 mm (0.06 – 0.08 in) when the shim thickness is changed by 0.10 mm (0.04 in).

Too low:

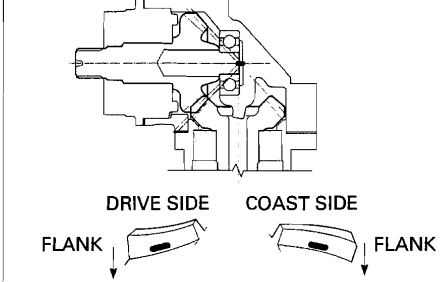

OUTPUT DRIVEN GEAR SHIMS:

- 0.20 mm (0.008 in)
- 0.25 mm (0.010 in)
- 0.30 mm (0.012 in)
- 0.35 mm (0.014 in)
- 0.40 mm (0.016 in) – Standard
- 0.45 mm (0.018 in)
- 0.50 mm (0.020 in)
- 0.55 mm (0.022 in)
- 0.60 mm (0.024 in)

OUTPUT DRIVEN GEAR SHIM REPLACEMENT

Hold the output gear case in a vise with soft jaws.
Remove the bolts and output driven gear assembly.

OUTPUT DRIVEN GEAR ASSEMBLY

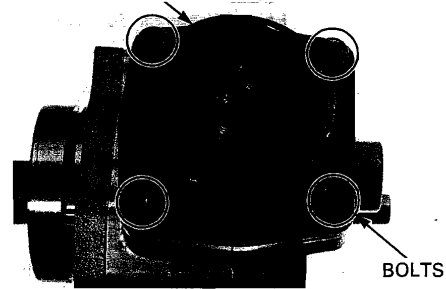

Remove the shim and O-ring from the bearing holder.

Select the replacement shim (page 13-35).

Coat a new O-ring with engine oil and install it into the bearing holder groove.
Install the shim.

Install the driven gear assembly to the gear case and tighten the bolts (page 13-41).

Recheck the contact pattern (page 13-34).

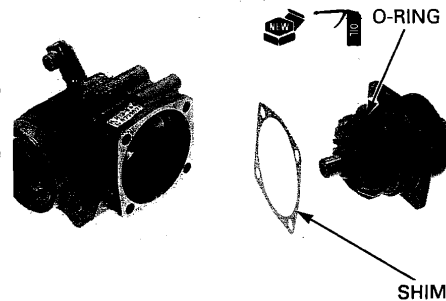

OUTPUT DRIVE GEAR DISASSEMBLY

Hold the output gear case in a vise with soft jaws.
Unstake the bearing inner/outer race lock nuts.

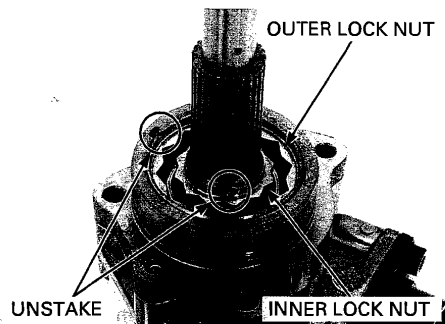

Remove the bearing inner race lock nut using the special tools.

TOOLS:

Shaft holder A

07PAB-0010100 or
07923-6890101
(U.S.A. only)

Holder handle

07PAB-0010400

Lock nut wrench, 36 x 47.8 mm

07916-MB00002

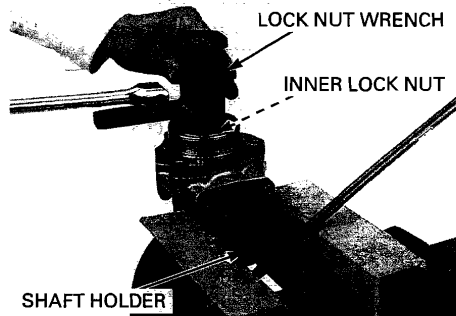

Remove the bearing outer race lock nut using a special tool.

TOOL:

Lock nut wrench, 36 x 47.8 mm 07916-MB00002

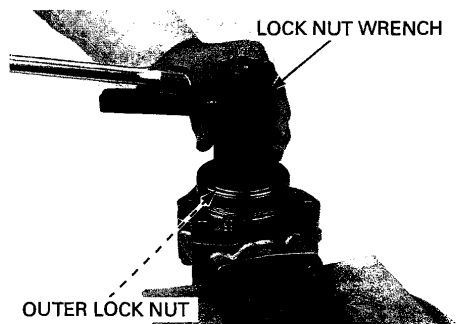

Remove the two bolts and drive gear assembly from the gear case.

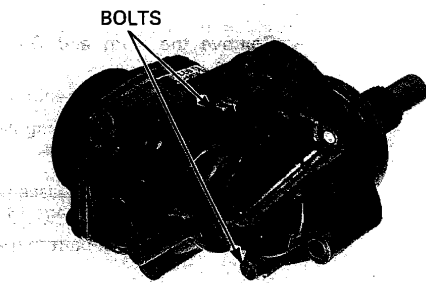

Remove the dowel pin, shim and O-ring from the bearing holder.

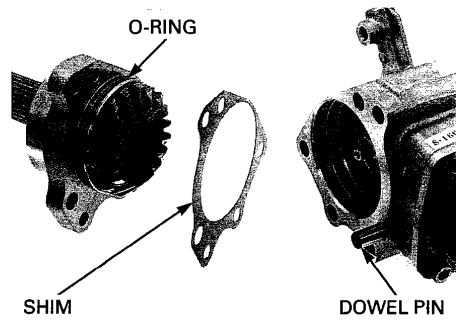

Press the drive gear out of the bearing using a hydraulic press.

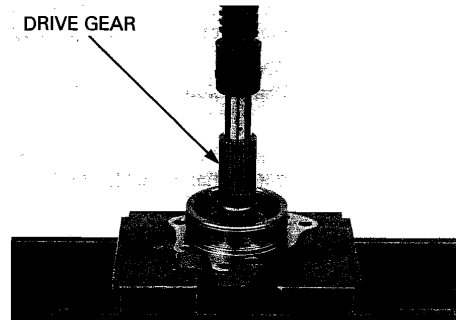

Press the drive gear bearing out of the bearing holder using the special tools and a hydraulic press.

TOOLS:

- | | |
|------------------------|---------------|
| Driver | 07749-0010000 |
| Attachment, 52 x 55 mm | 07746-0010400 |
| Pilot, 30 mm | 07746-0040700 |

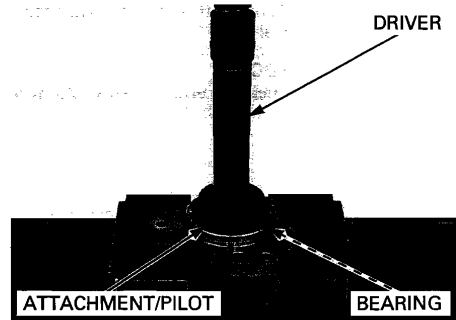

OUTPUT DRIVEN GEAR DISASSEMBLY

Hold the output gear case in a vise with soft jaws.
Remove the stopper ring and oil seal.

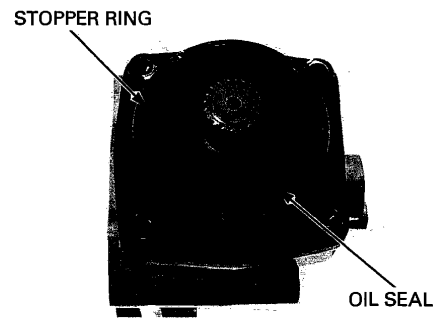

CRANKSHAFT/TRANSMISSION

Unstake the bearing inner and outer race lock nuts.

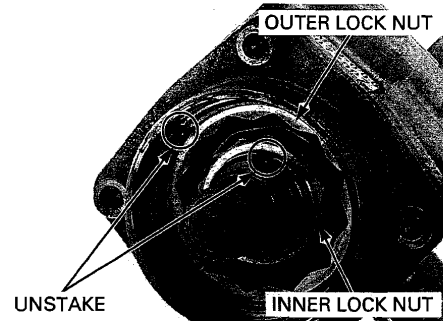

Hold the driven gear shaft and remove the bearing inner race lock nut using the special tools.

TOOLS:

Shaft holder A

07PAB-0010100 or
07923-6890101
(U.S.A. only)

Lock nut wrench, 36 x 47.8 mm

07916-MB00002
Differential inspection tool
07KMK-HC50101 or
07KMK-HC5010A
(U.S.A. only)

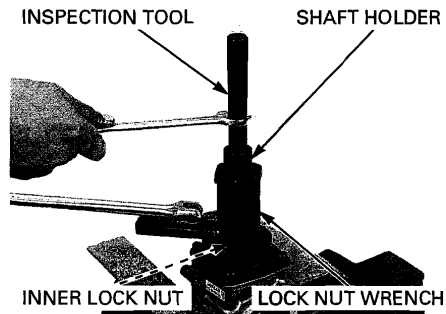

Remove the bearing outer race lock nut using a special tool.

TOOL:

Lock nut wrench, 36 x 47.8 mm 07916-MB00002

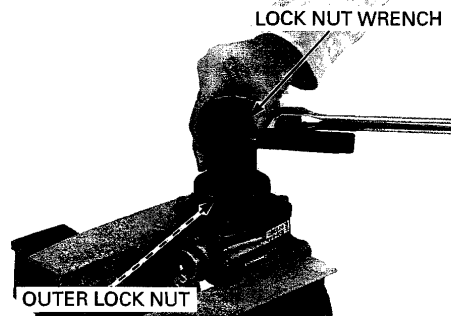

Remove the bolts and driven gear assembly from the gear case.

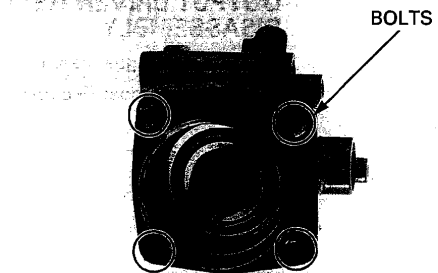

Remove the shim and O-ring from the bearing holder.

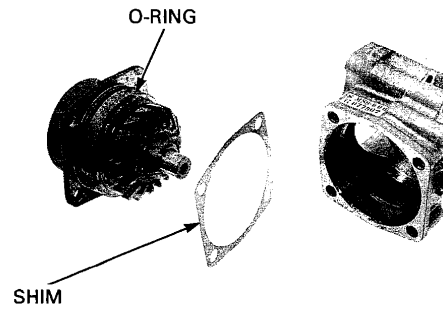

Press the driven gear out of the bearing using a hydraulic press.

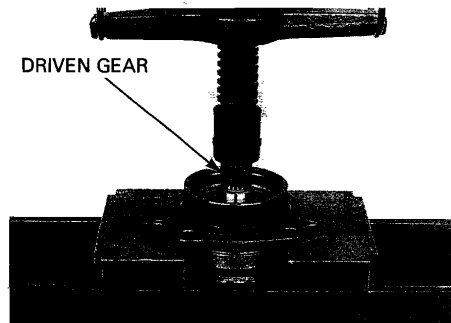

Press the driven gear bearing out of the bearing holder using the special tools and a hydraulic press.

- TOOLS:**
Driver 07749-0010000
Attachment, 52 x 55 mm 07746-0010400
Pilot, 30 mm 07746-0040700

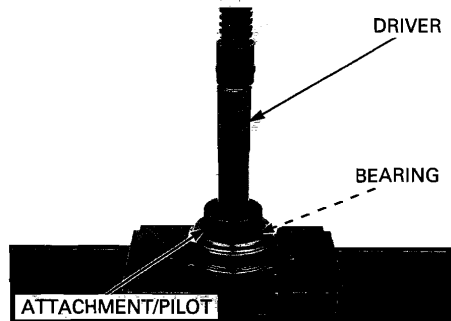

Remove the driven gear case bearing using the special tools.

- TOOLS:**
Bearing remover set, 17 mm 07936-3710300
Remover handle 07936-3710100
Remover weight 07741-0010201 or 07936-371020A or 07936-3710200 (U.S.A. only)

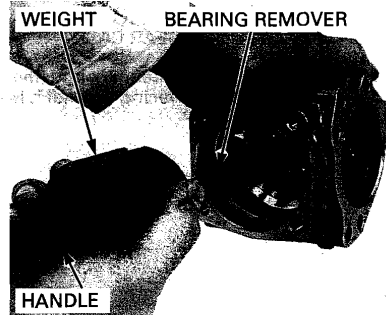

CRANKSHAFT/TRANSMISSION

Blow oil passage in the output gear case with compressed air.

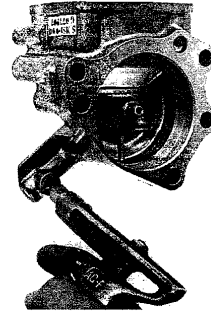

OUTPUT DRIVEN GEAR ASSEMBLY

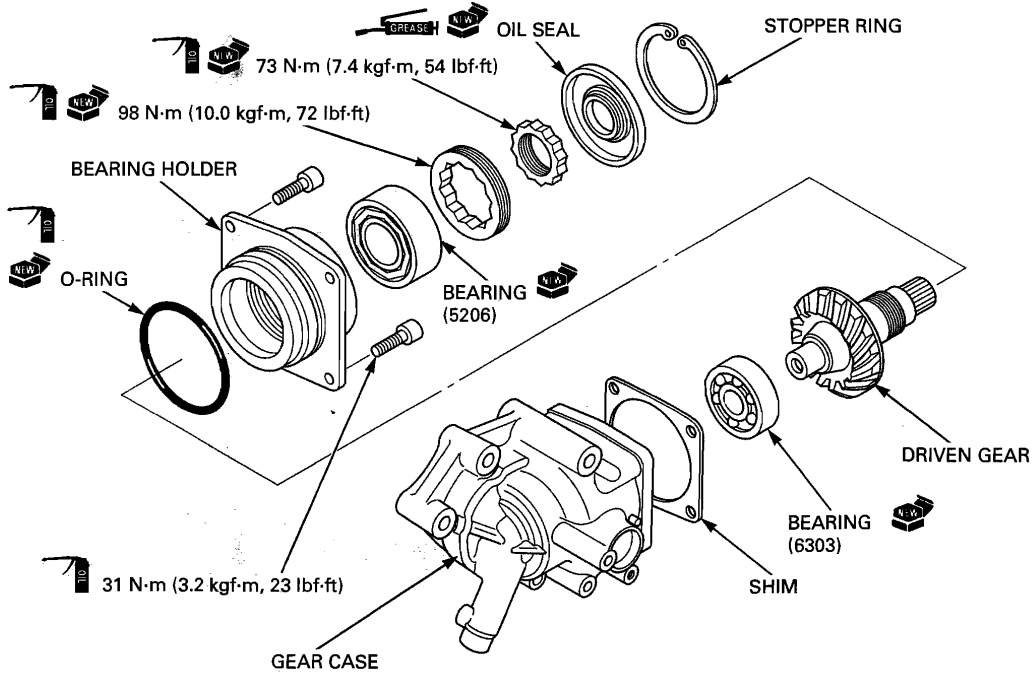

Drive a new bearing into the gear case with the marked side facing up until it is fully seated.

TOOLS:

Driver
Attachment, 42 x 47 mm
Pilot, 17 mm

07749-001000
07746-0010300
07746-0040400

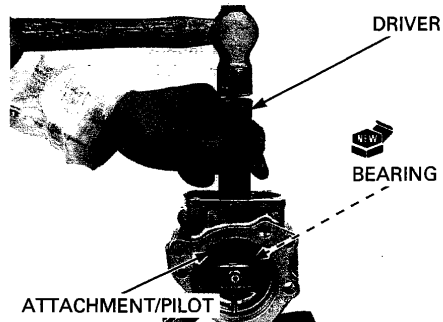

Press a new bearing into the bearing holder with the marked side facing up until it is fully seated and make sure it rotates freely after installation.

TOOL:
Oil seal driver 07965-KE80200

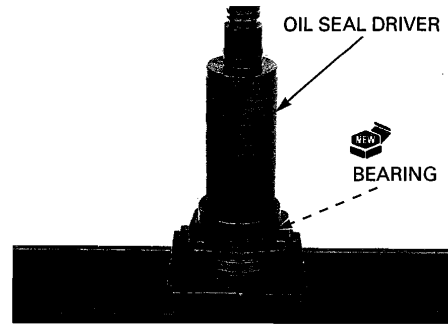

If the output driven gear requires replacement, the driven and drive gear must be replaced as a set. Support the bearing inner race and press the output driven gear into the bearing holder using the special tools.

TOOLS:
Driver, 40 mm I.D. 07746-0030100
Attachment, 30 mm I.D. 07746-0030300

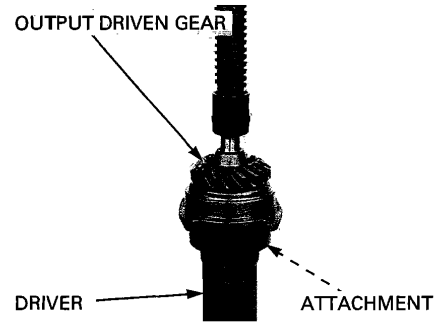

Coat a new O-ring with engine oil and install it into the bearing holder groove.
 Install the shim.

NOTE:
 When the bearing, gear, holder and/or case have been replaced, use the 0.40 mm (0.016 in) shim for initial reference.

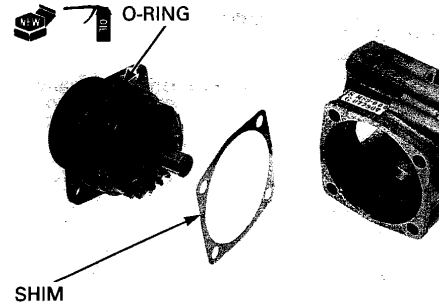

Hold the output gear case in a vise with soft jaws. Install the driven gear assembly into the gear case, aligning with the bolt holes.

Apply engine oil to the threads and seating surface of the bolts and tighten them.

TORQUE: 31 N·m (3.2 kgf·m, 23 lbf·ft)

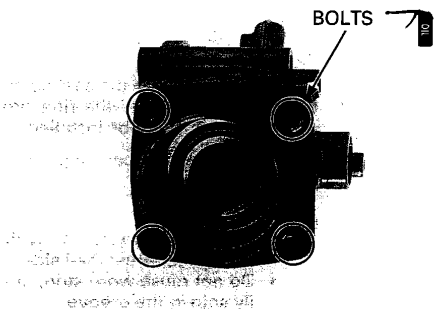

CRANKSHAFT/TRANSMISSION

Apply engine oil to the threads and seating surface of a new bearing outer race lock nut and tighten it to the specified torque using a special tool.

TOOL:
Lock nut wrench, 36 x 47.8 mm 07916-MB00002

Refer to torque wrench reading information, on page 13-3 "Service information".

TORQUE:
Actual: 98 N-m (10.0 kgf-m, 72 lbf-ft)
Indicated: 89 N-m (9.1 kgf-m, 66 lbf-ft)

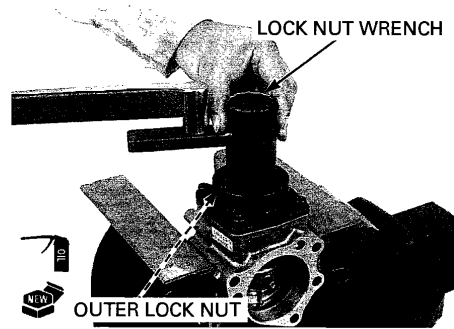

Apply engine oil to the threads and seating surface of a new inner race lock nut.

Hold the driven gear shaft and tighten it to the specified torque using the special tools.

TOOLS:
Shaft holder A 07PAB-0010100 or 07923-6890101 (U.S.A. only)
Lock nut wrench, 36 x 47.8 mm 07916-MB00002
Differential inspection tool 07KMK-HC50101 or 07KMK-HC5010A (U.S.A. only)

Refer to torque wrench reading information, on page 13-3 "Service information".

TORQUE:
Actual: 73 N-m (7.4 kgf-m, 54 lbf-ft)
Indicated: 66 N-m (6.7 kgf-m, 49 lbf-ft)

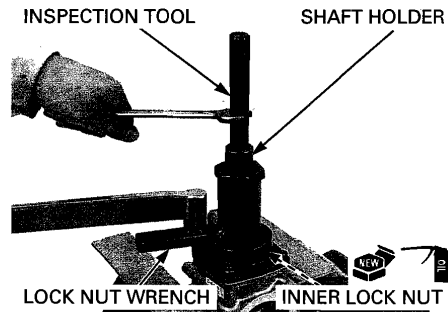

Stake the bearing inner and outer race lock nuts.

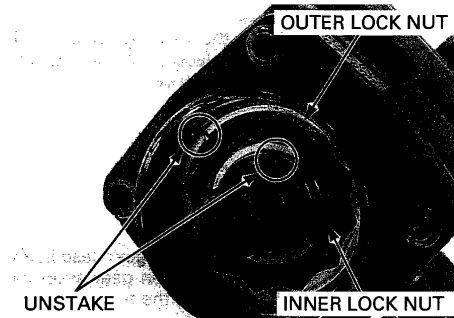

Pack grease into the seal lip cavity of a new oil seal and install it until the ring groove is visible so the stopper ring can be installed.

Install the stopper ring into the bearing holder groove securely.

- NOTE:**
- Install the stopper ring with the chamfered edge facing the thrust load side.
 - Do not reuse worn stopper ring which could easily spin in the groove.
 - Check that the stopper ring is seated in the groove.

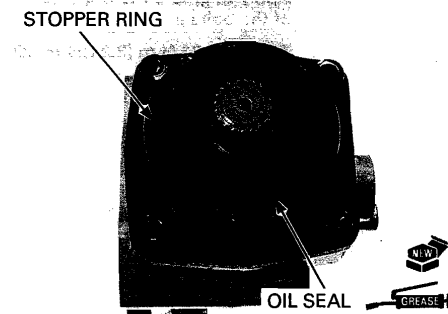

OUTPUT DRIVE GEAR ASSEMBLY

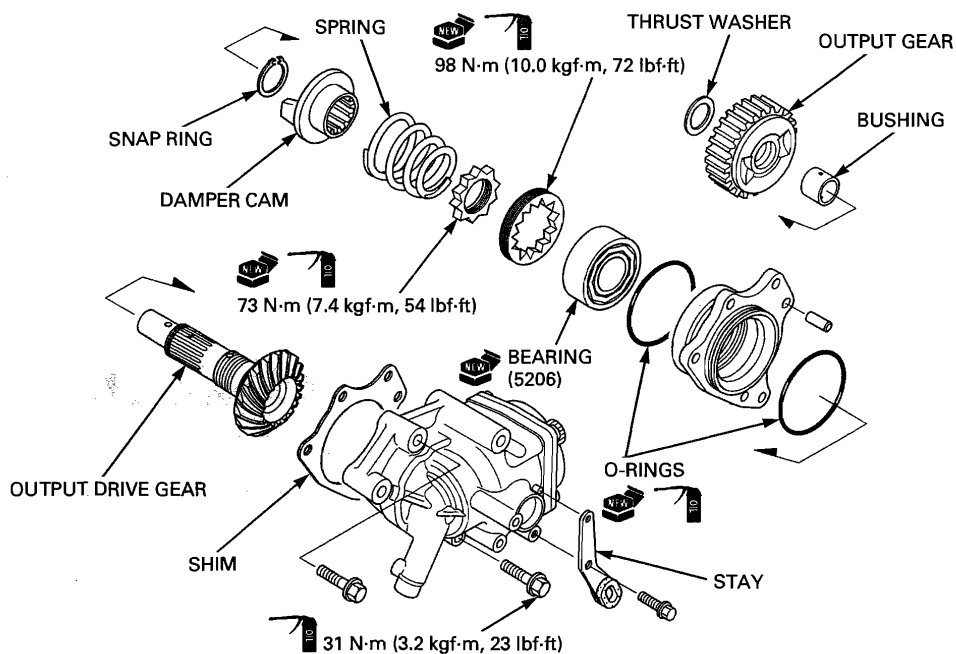

Press a new bearing into the bearing holder with the marked side facing up until it is fully seated.

TOOLS:

Driver 07749-0010000
 Attachment, 62 x 68 mm 07746-0010500
 Pilot, 30 mm 07746-0040700

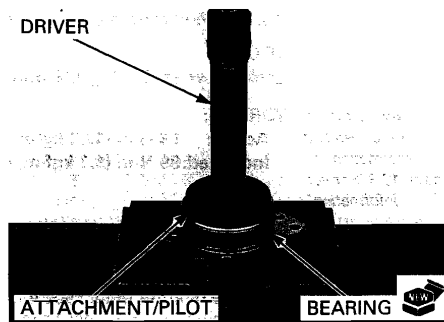

If the output drive gear requires replacement, the drive and driven gears must be replaced as a set.

Support the bearing inner race and press the output drive gear using the special tools.

TOOLS:

Driver, 40 mm I.D. 07746-0030100
 Attachment, 30 mm I.D. 07746-0030300
 Pilot, 22 mm 07746-0041000

NOTE:

- Place the pilot's threaded end into the drive shaft.
- If the bearing, gear, holder and/or case is replaced, a new shim must be selected (See page 13-33, Backlash Inspection).

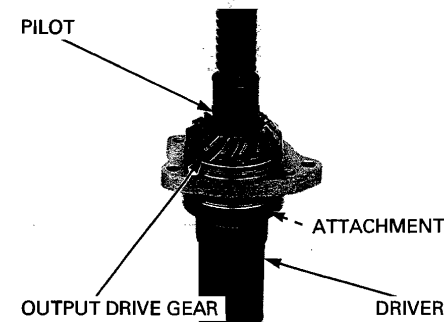

CRANKSHAFT/TRANSMISSION

Coat a new O-ring with engine oil and install it into the bearing holder groove.
Install the dowel pin and shim.

NOTE:

- When the bearing, gear, holder and/or case have been replaced, use the 0.50 mm (0.020 in) shim for initial reference.

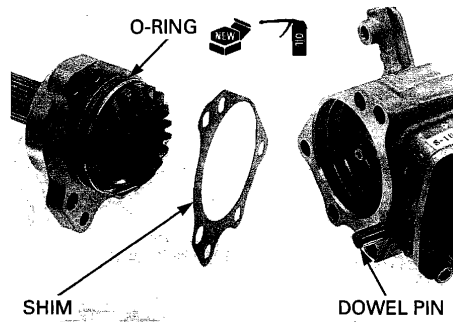

Install the drive gear assembly into the gear case.
Apply engine oil to the bolt threads and seating surface.
Tighten the bolts to the specified torque.

TORQUE: 31 N-m (3.2 kgf-m, 23 lbf-ft)

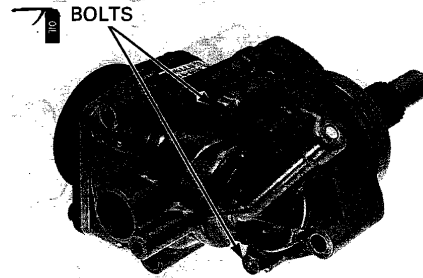

Hold the gear case in a vise with soft jaws.

Apply engine oil to the threads and seating surface of a new bearing outer race lock nut and tighten it to the specified torque using a special tool.

TOOL:

Lock nut wrench, 36 x 47.8 mm 07916-MB00002

TORQUE:

Actual: 98 N-m (10.0 kgf-m, 72 lbf-ft)
Indicated: 89 N-m (9.1 kgf-m, 66 lbf-ft)

Refer to torque wrench reading information, on page 13-3 "Service information".

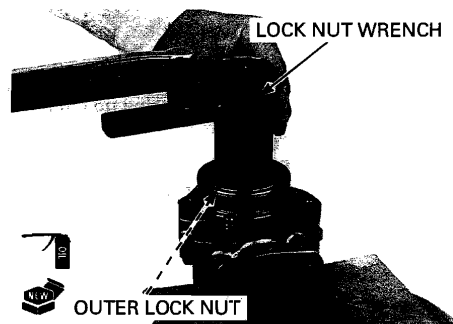

Apply engine oil to the threads and seating surface of a new bearing inner race lock nut and tighten it to the specified torque using the special tools.

TOOLS:

Lock nut wrench, 36 x 47.8 mm 07916-MB00002
Shaft holder A 07PAB-0010100 or 07923-6890101 (U.S.A. only)
Holder handle 07PAB-0010400

TORQUE:

Actual: 73 N-m (7.4 kgf-m, 54 lbf-ft)
Indicated: 66 N-m (6.7 kgf-m, 49 lbf-ft)

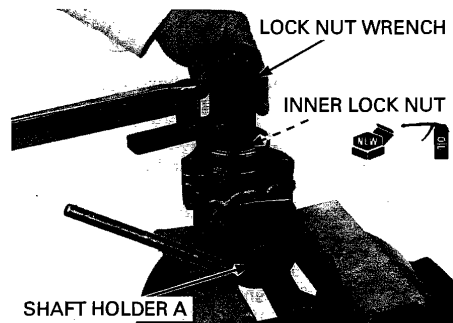

Stake the bearing inner and outer race lock nuts.

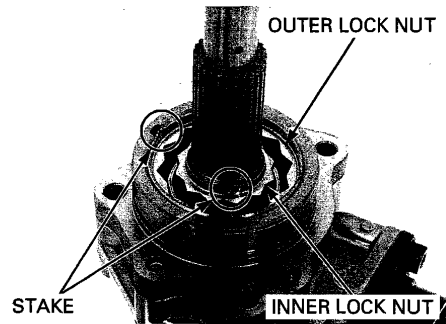

INSTALLATION

Coat new O-rings with engine oil and install them into the orifice grooves.
Install the orifice into the crankcase.

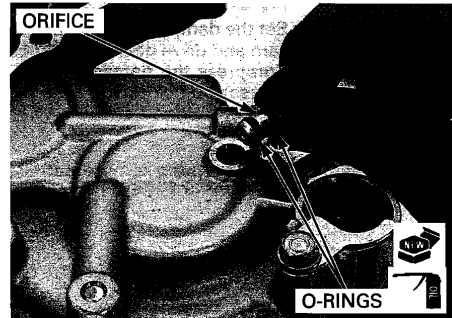

Coat a new O-ring with engine oil and install it into the groove in the gear case.

Install the output gear case assembly into the left crankcase by aligning the dowel pin with the crankcase hole.

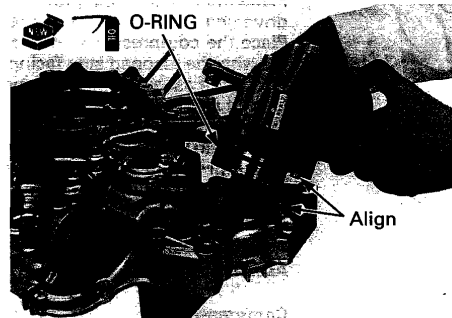

Apply sealant to the output gear case mounting bolt threads.
Tighten the bolts to the specified torque.

TORQUE: 31 N-m (3.2 kgf-m, 23 lbf-ft)

Install the stay, aligning its hole with the gear case boss and tighten the bolt securely.

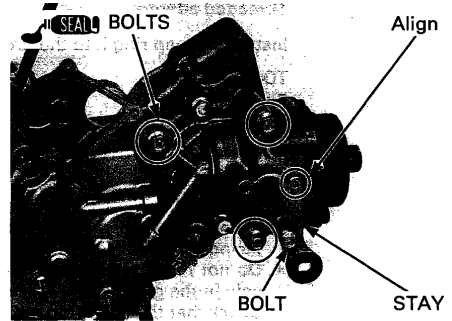

CRANKSHAFT/TRANSMISSION

Apply 1 g of molybdenum disulfide grease to the output drive gear and damper cam splines.

Install the damper spring over the output drive gear with the tightly wound coil facing the left crankcase. Install the damper cam onto the spring.

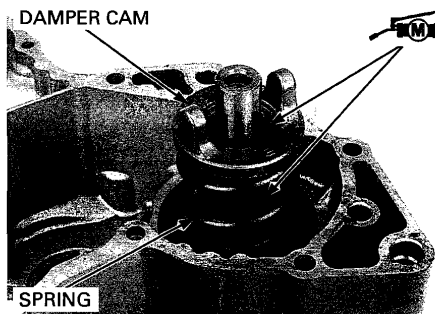

Install the snap ring on the damper cam.

(Except U.S.A.)

Set the damper spring compressor onto the damper cam and drive gear shaft. Compress the damper spring by turning the compressor bolt clockwise until the snap ring groove is visible.

TOOL:

Damper spring compressor 07964-ME90000

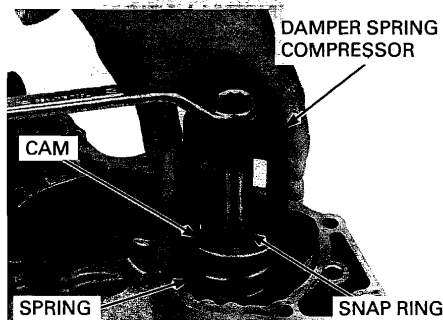

(U.S.A. only)

Place the threaded adaptor in the end of the output drive gear shaft and tighten the adaptor. Place the compressor seat over the threaded adaptor with the stepped side facing upward. Install the assembly bolt through the assembly collar and attach it to the threaded adaptor. Center the compressor seat with the damper cam then begin to tighten the 23 mm nut of the assembly bolt until the snap ring groove is visible so snap ring can be installed into the groove.

TOOLS:

Assembly bolt 07965-1660200
Assembly collar 07965-166030A or
07965-1660302
Compressor seat 07967-9690200
Threaded adaptor 07965-KA30000

Install the snap ring into the groove in the shaft.

TOOLS:

Snap ring pliers 07914-5670101
not available in
U.S.A. or
07914-5670100

NOTE:

- Install the snap ring with the chamfered edges facing the thrust load side.
- Do not reuse worn snap ring which could easily spin in the groove.
- Check that the snap ring is seated in the groove.

Loosen and remove the special tool.

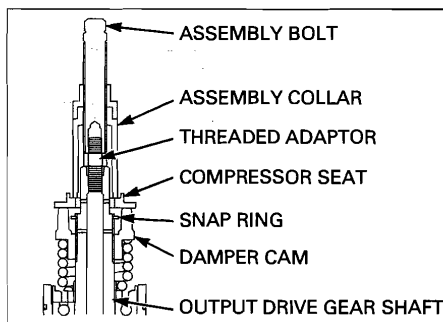

Install the bushing into the output gear shaft.

Install the output gear onto the gear shaft by aligning the damper cam projections with the output gear holes.

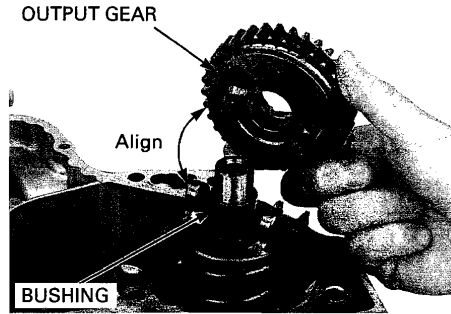

Install the thrust washer.

Install the following:

- Crankshaft (page 13-13)
- Transmission (page 13-27)
- Oil pump (page 5-11)

Assemble the crankcase (page 13-49).

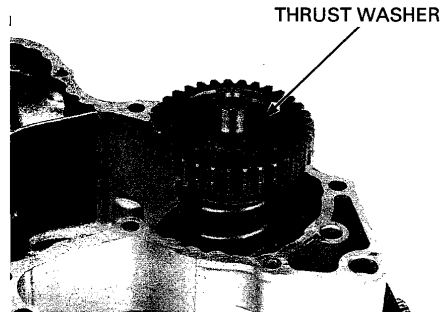

CRANKCASE BEARING REPLACEMENT

INSPECTION

Remove the following:

- Crankshaft (page 13-10)
- Transmission (page 13-20)
- Output gear (page 13-29)
- Oil pump (page 5-6)

Turn the inner race of each bearing with your finger. The bearings should turn smoothly and quietly. Also check that the bearing outer race fits tightly in the crankcase.

Remove and discard the bearings if the races does not turn smoothly, quietly, or if they fit loosely in the crankcase.

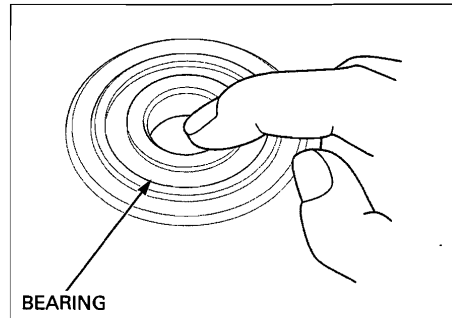

LEFT CRANKCASE BEARINGS

Remove the mainshaft and countershaft bearings using the special tools.

TOOLS:

Bearing remover set, 20 mm

Remover handle

Remover weight

07936-3710600

07936-3710100

07741-0010201 or

07936-371020A or

07936-3710200

(U.S.A. only)

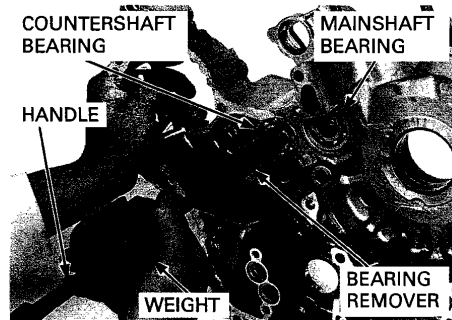

CRANKSHAFT/TRANSMISSION

Remove the oil guide plate from the crankcase.
Check the oil guide plate for clog or deformation.
Install the oil guide plate into the crankcase.

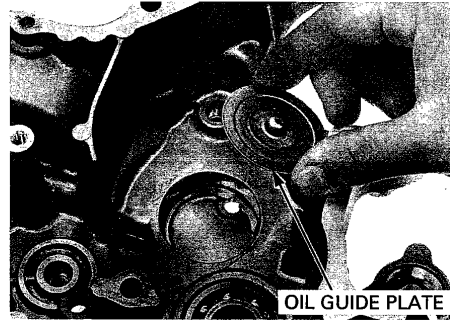

Drive new bearings into the left crankcase with the marked side facing up until they are fully seated.

TOOLS:

Driver	07749-001000
Attachment, 42 x 47 mm	07746-0010300

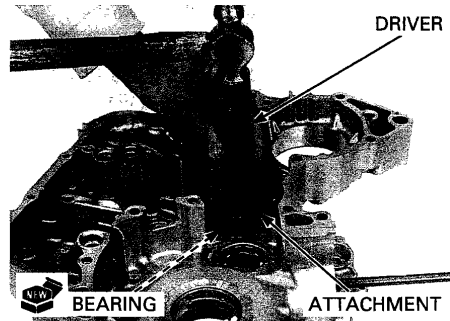

RIGHT CRANKCASE BEARINGS

Drive the bearings out of the right crankcase.

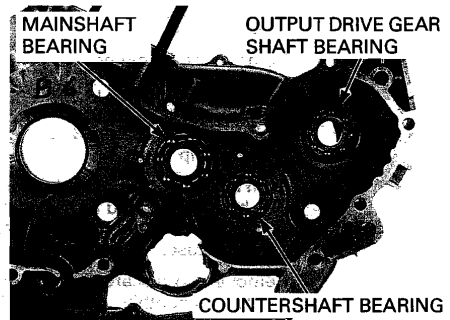

Drive new bearings into the right crankcase with the marked side facing up until they are fully seated.

TOOLS:

Mainshaft bearing:

Driver	07749-001000
Attachment, 52 x 55 mm	07746-0010400
Pilot, 22 mm	07746-0041000

Countershaft/output drive gear shaft bearings:

Driver	07749-001000
Attachment, 42 x 47 mm	07746-0010300
Pilot, 20 mm	07746-0040500

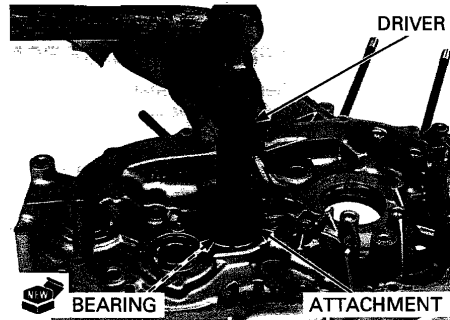

CRANKCASE ASSEMBLY

Clean the left and right crankcase mating surfaces thoroughly, being careful not to damage them.

Make sure the all parts are installed in the left crankcase.

Apply liquid sealant to the right and left crankcase mating surfaces.

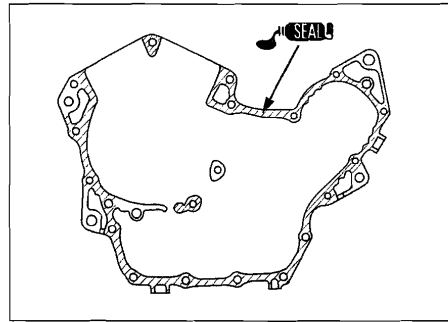

Install the two dowel pins into the left crankcase. Coat a new pipe seal with engine oil and install it to the oil pipe.

NOTE:

Install a new pipe seal with its tapered side facing out.

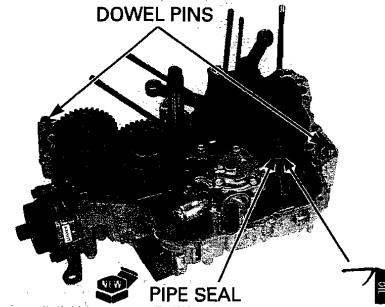

Install the right crankcase over the left crankcase.

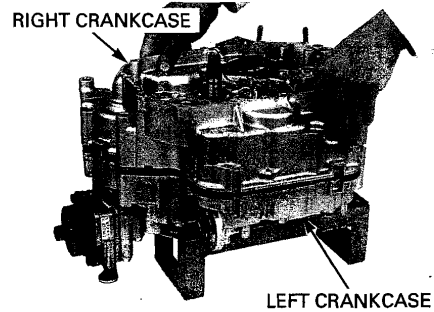

Turn the shift drum until the position as shown.

Install the right crankcase bolts with the washer.

Tighten the 8 mm bolts in a crisscross pattern in several steps.

TORQUE:

8 mm bolt: 23 N·m (2.3 kgf·m, 17 lbf·ft)

Tighten the 6 mm bolts securely.

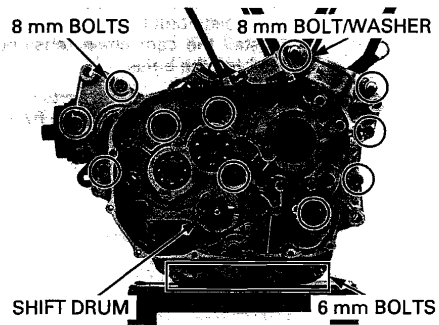

CRANKSHAFT/TRANSMISSION

Install the left crankcase bolts and tighten the 8 mm bolts in a crisscross pattern in several steps.

TORQUE:

8 mm bolt: 23 N-m (2.3 kgf-m, 17 lbf-ft)

Tighten the 6 mm bolts securely.

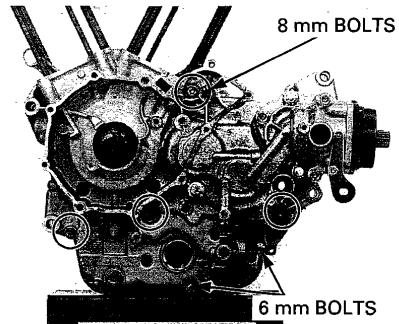

Clean and apply locking agent to the bolt threads (page 1-19). Install the bearing setting plate and tighten the bolts.

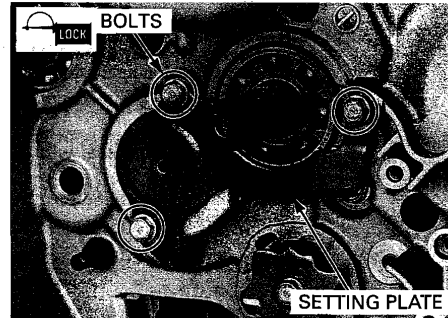

Install and tighten the bolt with the washer by holding the output driven gear shaft using the special tools.

TOOLS:

Shaft holder A

07PAB-0010100 or
07923-6890101
(U.S.A. only)

Holder handle

07PAB-0010400

TORQUE: 49 N-m (5.0 kgf-m, 36 lbf-ft)

Recheck the all crankcase bolt torque values.

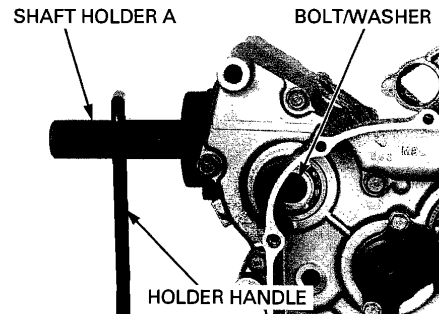

Install the cam chains.

Apply locking agent to the cam chain tensioner setting plate bolt threads (page 1-19).

Install the cam chain tensioner setting plates and tighten the bolts.

Install the remaining parts (page 13-3).

Install the engine into the frame (page 8-7).

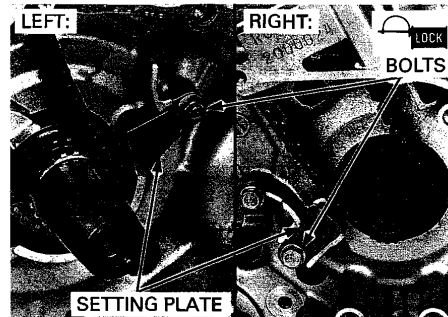

14. FINAL DRIVE

COMPONENT LOCATION	14-2	FINAL DRIVE DISASSEMBLY/ INSPECTION	14-8
SERVICE INFORMATION	14-3	FINAL DRIVE ASSEMBLY	14-17
TROUBLESHOOTING	14-6	FINAL DRIVE INSTALLATION	14-22
FINAL DRIVE REMOVAL	14-7		

COMPONENT LOCATION

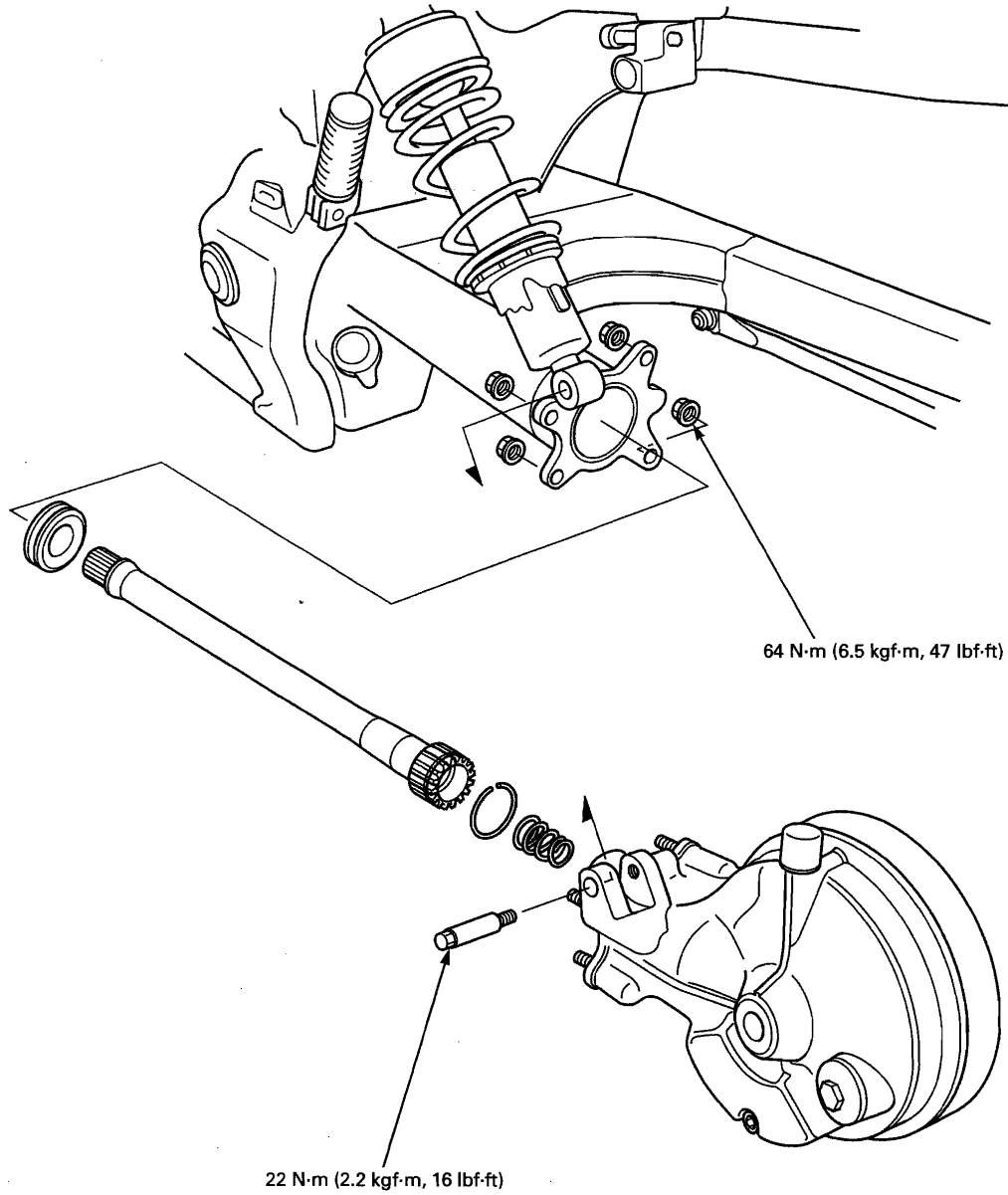

SERVICE INFORMATION

GENERAL

- The final drive gear assembly and final drive shaft must be removed together.
- Perform the gear contact pattern and backlash inspection whenever you replace the bearings, gears or gear case. the extension lines from the gear engagement surfaces should intersect at one point.
- Protect the gear case with a shop towel or soft jaws while holding it in a vise. Do not clamp the gear case too tightly or it could be damaged.
- Replace the ring and pinion gears as a set.

SPECIFICATIONS

ITEM		STANDARD	SERVICE LIMIT
Recommended final drive oil		Hypoid gear oil, SAE #80	-
Final drive oil capacity	At draining	160 cm ³ (5.4 US oz, 5.6 Imp oz)	-
	At disassembly	170 cm ³ (5.7 US oz, 6.0 Imp oz)	-
Final drive gear backlash		0.05 – 0.15 (0.002 – 0.006)	0.30 (0.012)
Backlash difference between measurements		-	0.10 (0.004)
Ring gear-to-stop pin clearance		0.30 – 0.60 (0.012 – 0.024)	-
Final drive gear assembly pre-load		0.2 – 0.4 N·m (2 – 4 kgf·cm, 0.1 – 0.3 lbf·ft)	-

Unit: mm (in)

TORQUE VALUES

Pinion retainer	108 N·m (11.0 kgf·m, 80 lbf·ft)	
Pinion retainer lock tab bolt	10 N·m (1.0 kgf·m, 7 lbf·ft)	
Pinion joint nut	108 N·m (11.0 kgf·m, 80 lbf·ft)	Apply locking agent to the threads
Dust guard plate bolt	10 N·m (1.0 kgf·m, 7 lbf·ft)	
Final gear case cover 10 mm bolt	47 N·m (4.8 kgf·m, 35 lbf·ft)	Apply locking agent to the threads
Final gear case cover 8 mm bolt	25 N·m (2.5 kgf·m, 18 lbf·ft)	
Final gear case assembly mounting nut	64 N·m (6.5 kgf·m, 47 lbf·ft)	
Rear shock absorber lower mounting bolt (left side)	22 N·m (2.2 kgf·m, 16 lbf·ft)	
Final gear case stud bolt	See page 14-22	

FINAL DRIVE

TOOLS

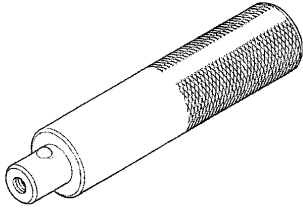
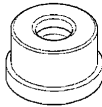
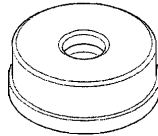
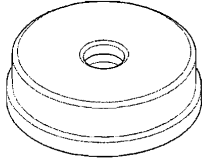
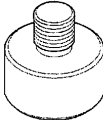
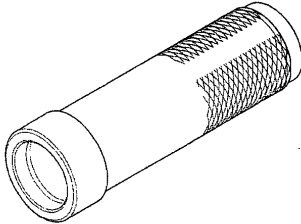
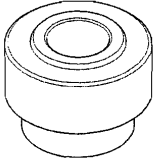
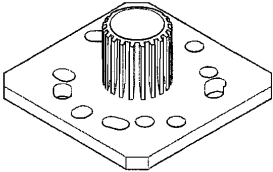
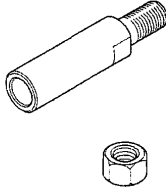
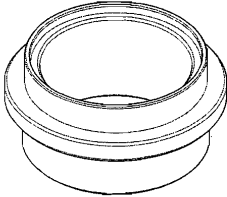
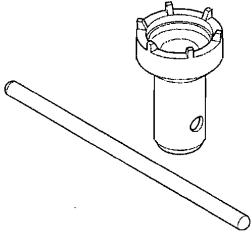
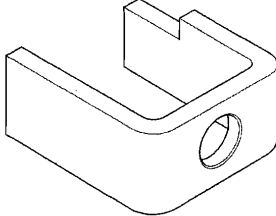
<p>Driver 07749-0010000</p> 	<p>Attachment, 32 x 35 mm 07746-0010100</p> 	<p>Attachment, 52 x 55 mm 07746-0010400</p> 
<p>Attachment, 72 x 75 mm 07746-0010600</p> 	<p>Pilot, 19 mm 07746-0041400</p> 	<p>Driver, 40 mm I.D. 07746-0030100</p> 
<p>Attachment, 25 mm I.D. 07746-0030200</p> 	<p>Pinion holder plate 07924-ME40010</p> 	<p>Collar set "C" 07924-ME40020</p> 
<p>Oil seal driver 070MF-MEG0300</p> 	<p>Retainer wrench 07910-MA10100</p> 	<p>Pinion puller base 07HMC-MM80110 or 07HMC-MM8011A (U.S.A. only)</p> 

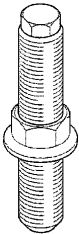
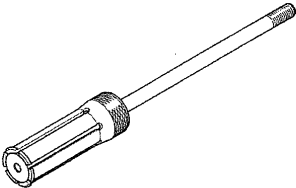
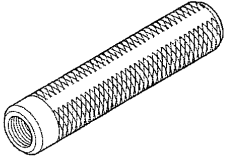
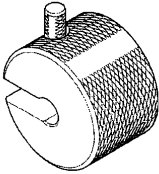
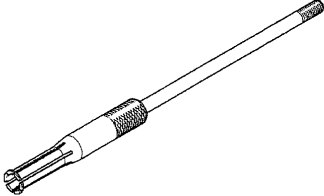
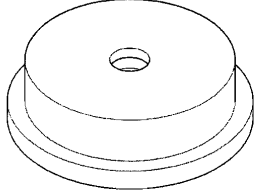
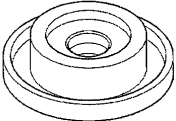
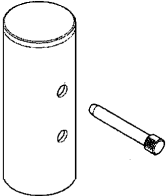
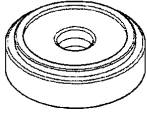
<p>Puller shaft 07931-ME40000</p>  <p>or 07931-ME4010B and 07931-HB3020A (U.S.A. only)</p>	<p>Bearing remover, 35 mm 07936-3710400</p> 	<p>Remover handle 07936-3710100</p> 
<p>Remover weight 07741-0010201</p>  <p>or 07936-371020A or 07936-3710200 (U.S.A. only)</p>	<p>Bearing remover, 20 mm 07936-3710600</p>  <p>or equivalent commercially available in U.S.A.</p>	<p>Bearing driver attachment 07GAD-SD40101</p> 
<p>Oil seal driver attachment 07LAD-SM40100</p>  <p>or 07LAD-SM4A100 (U.S.A. only)</p>	<p>Oil seal driver, 55.7 x 60.3 mm 07965-KE80200</p> 	<p>Attachment, 44 x 49.5 mm 07945-3330300</p> 

TROUBLESHOOTING

Excessive noise

- Worn or scored ring gear shaft and driven flange
- Scored driven flange and wheel hub (page 16-7)
- Worn or scored drive pinion and splines
- Worn pinion and ring gears
- Excessive backlash between pinion and ring gears
- Oil level too low
- Worn or damaged pinion gear and/or pinion joint splines

Oil leak

- Clogged breather
- Oil level too high
- Damaged seals
- Loose case cover bolts

Excessive rear wheel backlash

- Worn drive shaft splines
- Excessive backlash between pinion and ring gears
- Worn driven flange and ring gear splines
- Excessive play in final drive case bearings
- Worn drive shaft, universal joint and/or pinion joint splines
- Excessive play or worn universal joint bearing

FINAL DRIVE REMOVAL

Drain the final drive oil (page 4-18).
Remove the rear wheel (page 16-6).

Remove the left shock absorber lower mounting bolt.

Remove the four mounting nuts and final drive gear case assembly.

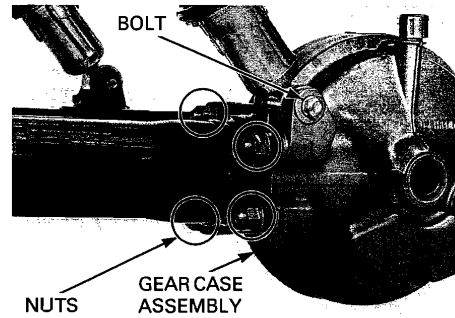

Remove the drive shaft from the final drive gear case assembly by gently turning the drive shaft and pulling it.

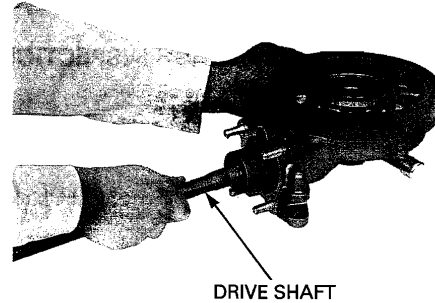

Remove the spring, oil seal and stopper ring from the drive shaft.

INSPECTION

Check the splines of the drive shaft for wear or damage.

If the splines of the drive shaft are damaged, check the universal joint splines also (page 16-24).

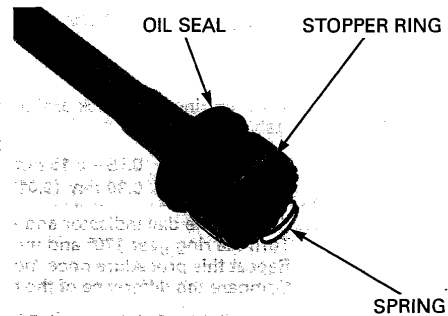

Turn the pinion joint and check that the pinion and ring gears turn smoothly and quietly without binding.

If the gears do not turn smoothly or quietly, the gears and/or bearing may be damaged or faulty. They must be checked after disassembly; replace faulty parts/assemblies as required.

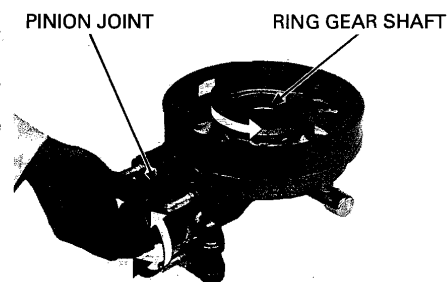

FINAL DRIVE DISASSEMBLY/ INSPECTION

NOTE:

Perform the backlash inspection and contact pattern check whenever you replace the pinion gear, ring gear, bearings and gear case. The extension lines from the gear engagement surfaces should intersect at one point.

Remove the final drive and drive shaft (page 14-7).

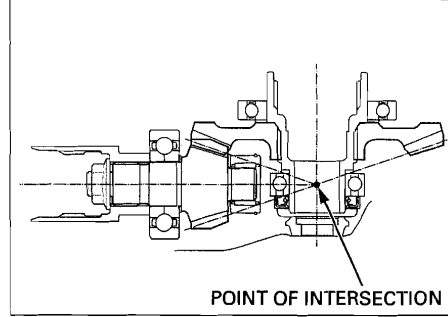

BACKLASH INSPECTION

Remove the oil filler cap.

Do not over-tighten the vice on the final drive case.

Hold the final drive gear case assembly in a vise with soft jaws.

Install the special tools onto the gear case and into the pinion joint to hold the pinion gear.

TOOLS:

- Pinion holder plate **07924-ME40010**
- Collar set "C" **07924-ME40020**

Set a horizontal type dial indicator on the ring gear, through the oil filler hole.

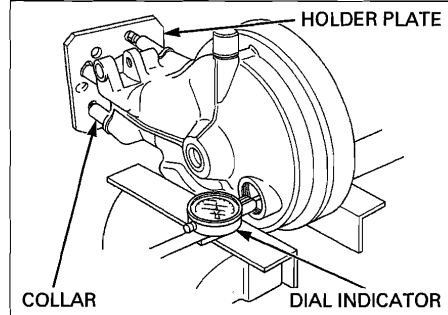

Turn the ring gear back and forth to read the backlash.

STANDARD: 0.05 – 0.15 mm (0.002 – 0.006 in)
SERVICE LIMIT: 0.30 mm (0.012 in)

Remove the dial indicator and special tools. Turn the ring gear 120° and measure the backlash. Repeat this procedure once more. Compare the difference of the three measurements.

SERVICE LIMIT: 0.10 mm (0.004 in)

If the difference in measurements exceeds the service limit, it indicates that the bearing is not installed squarely, or the case is deformed. Inspect the bearings and case.

If the backlash is excessive, replace the ring gear shim with a thicker one.

If the backlash is too small, replace the ring gear shim with a thinner one.

RING GEAR SHIMS:

- A: 1.82 mm (0.072 in)
- B: 1.88 mm (0.074 in)
- C: 1.94 mm (0.076 in)
- D: 2.00 mm (0.079 in) – Standard
- E: 2.06 mm (0.081 in)
- F: 2.12 mm (0.083 in)
- G: 2.18 mm (0.086 in)
- H: 2.24 mm (0.088 in)
- I: 2.30 mm (0.091 in)

For ring gear shim replacement (page 14-11).

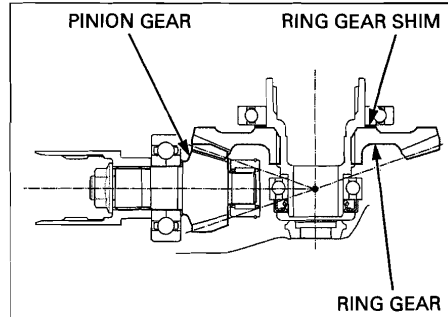
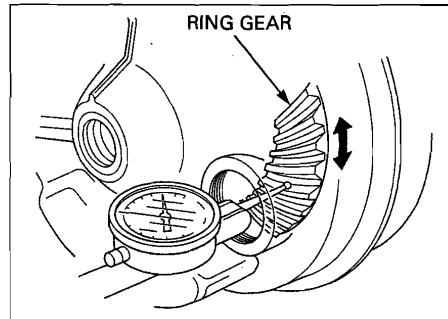

FINAL GEAR CASE SEPARATION

Remove the bolt, washer and the dust guard plate by turning it clockwise.

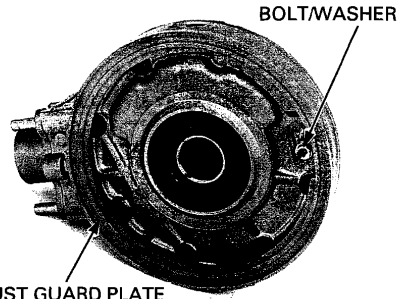

Remove the O-ring.
Loosen the cover bolts in a crisscross pattern in several steps and remove them.
Pry the gear case cover and remove it from the case.
Remove the wave washer.

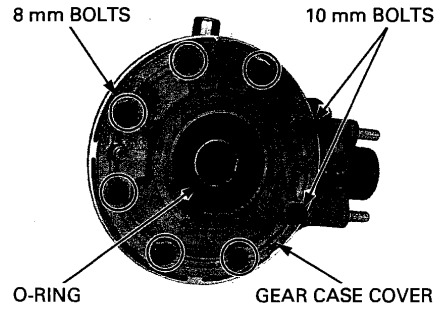

GEAR TOOTH CONTACT PATTERN CHECK

Description of the tooth:

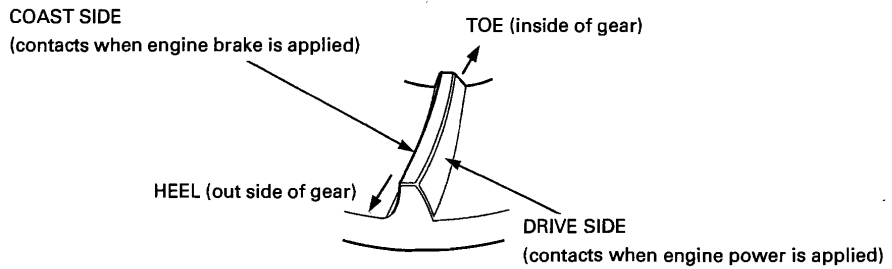

Keep dust and dirt out of the case and cover. Clean the sealing material off the mating surfaces of the gear case and cover, being careful not to damage them.
Apply a thin coat of Prussian Blue to the pinion gear teeth.
Install the wave washer.

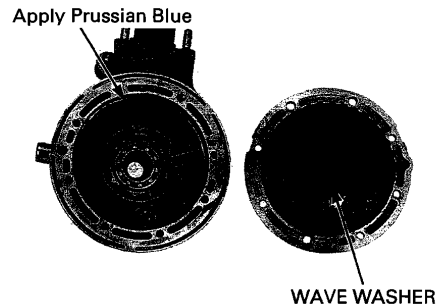

FINAL DRIVE

Install the case cover and tighten the bolts in a criss-cross pattern in several steps until the cover evenly touches the gear case.

Tighten the two 10 mm bolts to the specified torque in several steps alternately.

TORQUE: 47 N-m (4.8 kgf-m, 35 lbf-ft)

Tighten the six 8 mm bolts to the specified torque in a crisscross pattern in several times.

TORQUE: 25 N-m (2.5 kgf-m, 18 lbf-ft)

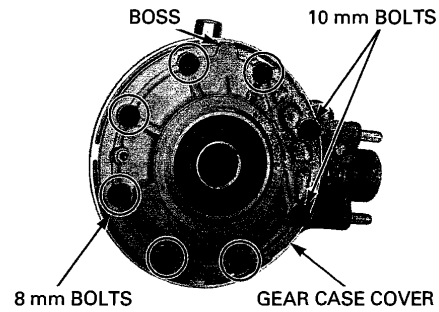

Remove the oil filler cap.

Rotate the ring gear several times in normal direction of rotation.
Check the gear tooth contact pattern through the oil filler hole.

Contact is normal if the Prussian Blue is transferred to the approximate center of each tooth and slightly towards the face.

If the patterns are not correct, remove and replace the pinion gear shim with a suitable one (page 14-12).

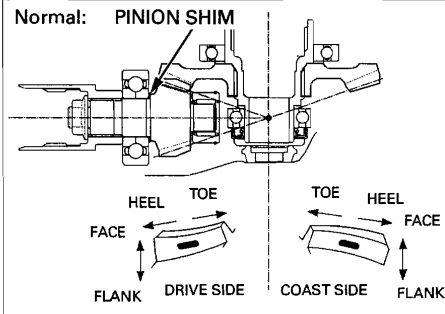

Replace the pinion gear shim with a thicker one if the contact pattern is too high, toward the face.

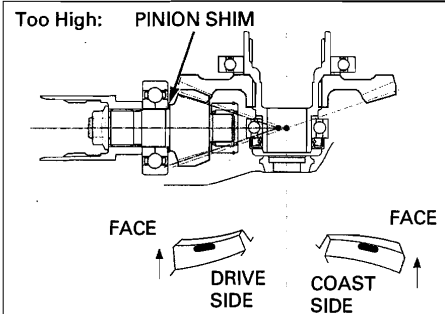

Replace the pinion gear shim with a thinner one if the contact pattern is too low, toward the flank.

The patterns will shift about 1.5 – 2.0 mm (0.06 – 0.08 in) when the thickness of the shim is changed by 0.1 mm (0.004 in).

PINION GEAR SHIMS:

- A: 1.82 mm (0.072 in)
- B: 1.88 mm (0.074 in)
- C: 1.94 mm (0.076 in)
- D: 2.00 mm (0.079 in) – Standard
- E: 2.06 mm (0.081 in)
- F: 2.12 mm (0.083 in)
- G: 2.18 mm (0.086 in)

For pinion gear shim replacement (page 14-13).

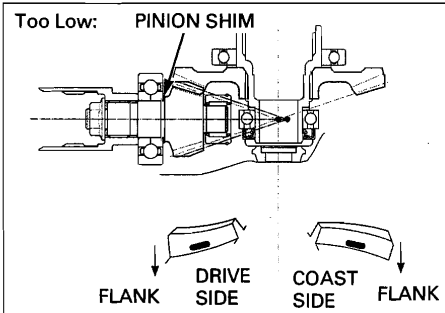

RING GEAR REMOVAL/SHIM REPLACEMENT

Remove the final gear case cover (page 14-9).

If the ring gear stays in the cover, remove it as follows:

Press the ring gear out of the gear case cover using the special tools and hydraulic press.

TOOLS:

Driver

Oil seal driver attachment

07749-0010000

07LAD-SM40100 or

07LAD-SM4A100

(U.S.A. only)

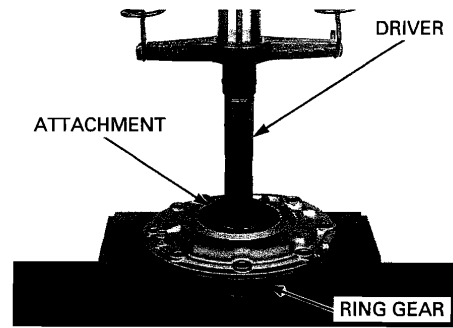

Remove the oil seal.

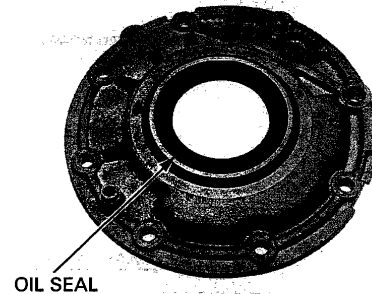

If the bearing remained in the cover, remove it as follows:

Press the oil seal and bearing out of the cover using the special tools and hydraulic press.

TOOLS:

Driver

Oil seal driver

Attachment, 72 x 75 mm

07749-0010000

070MF-MEG0300

07746-0010600

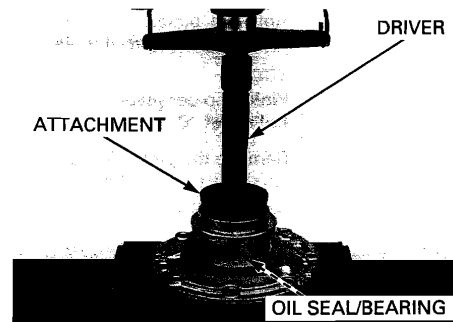

If the bearing remained on the ring gear, remove it as follows:

Remove the ring gear bearing using a commercially available bearing puller.

This bearing may not need to be replaced after removal. However, inspect the bearing for excessive play after removal.

Replace it if necessary.

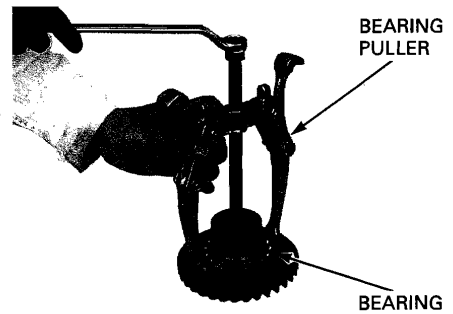

FINAL DRIVE

Select the replacement shim (page 14-8).

NOTE:

When the gear set, pinion bearing, ring gear bearing and/or gear case has been replaced, use a 2.00 mm (0.079 in) thickness shim for initial reference.

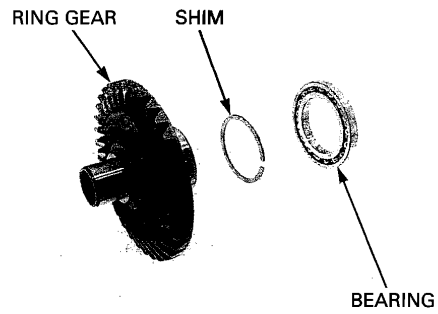

Press the ring gear bearing into the cover with the marked side facing inside until it is fully seated.

TOOLS:

Driver 07749-0010000
Bearing driver attachment 07GAD-SD40101

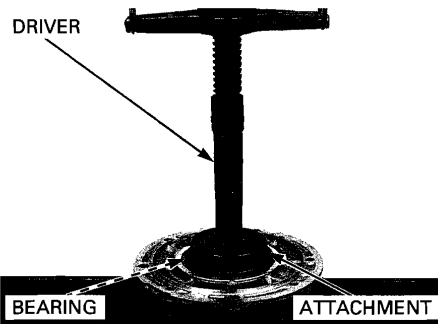

PINION GEAR REMOVAL

Hold the gear case in a vise with soft jaws.

Hold the pinion joint and remove the pinion joint nut using the special tools.

TOOLS:

Pinion holder plate 07924-ME40010
Collar set "C" 07924-ME40020

Remove the pinion joint.

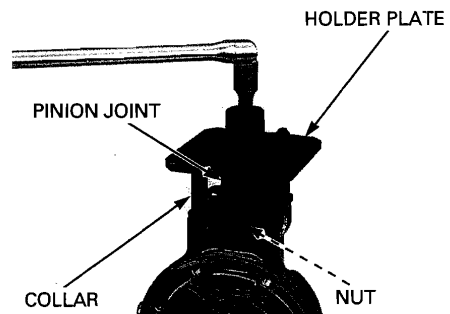

Remove the bolt and retainer lock tab.

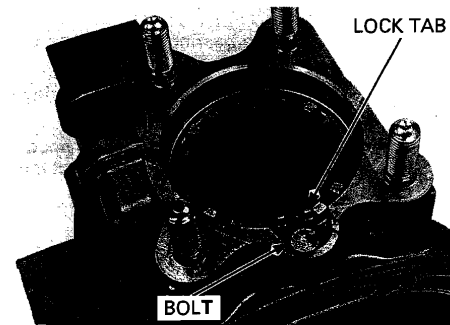

Remove the pinion retainer using the special tool.

TOOL:
Retainer wrench **07910-MA10100**

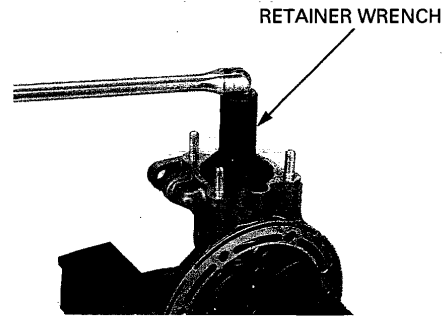

Remove the O-ring and oil seal from the pinion retainer.

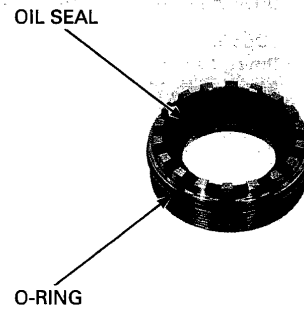

Install the special tools onto the pinion gear shaft and gear case.

TOOLS:
Except U.S.A.
Pinion puller base **07HMC-MM80110**
Puller shaft **07931-ME40000**

U.S.A. only
Puller base "A" **07HMC-MM8011A**
Assembly shaft, 22 x 1.5 x 240 mm **07931-ME4010B and 07931-HB3020A**
Special nut **07931-ME4010B and 07931-HB3020A**

Pull the pinion gear assembly out of the gear case. Check the pinion gear needle bearing in the gear case for wear or damage.

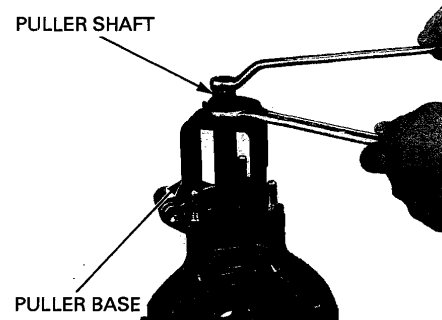

**PINION GEAR BEARING REMOVAL/
SHIM REPLACEMENT**

Pull the pinion gear bearing from the shaft with a commercially available bearing puller.

This bearing may not need to be replaced after removal. However, inspect the bearing for excessive play after removal.

Remove the pinion shim.

Replace it if necessary.

Replace the pinion gear bearing and inner races as a set.

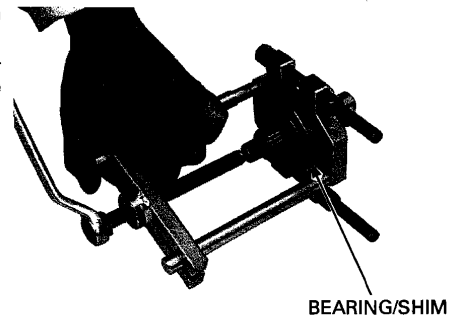

Select the replacement shim (page 14-10).

Install the shim, bearing and inner races onto the pinion gear.

NOTE:

When the gear set, pinion bearing, ring gear bearing and/or gear case has been replaced, use a 2.00 mm (0.079 in) thickness shim for initial reference.

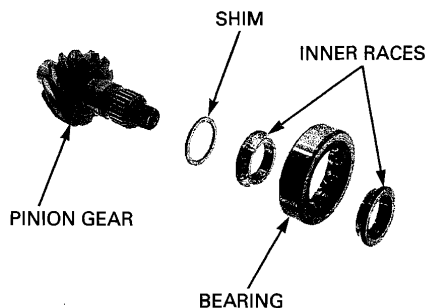

Drive the bearing with the marked side facing up.

TOOLS:

Driver, 40 mm I.D.

07746-0030100

Attachment, 25 mm I.D.

07746-0030200

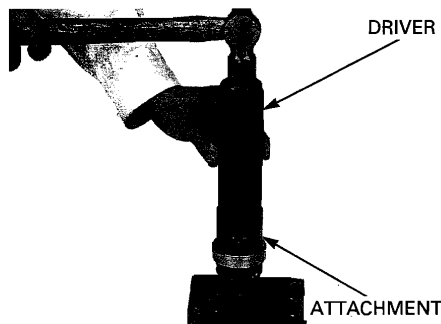

CASE BEARING REPLACEMENT

RING GEAR CASE BEARING

Be sure to wear heavy gloves when handling the heated gear case.

Heat the gear case to 80°C (176°F) evenly using a heat gun.

Remove the ring gear case bearing from the gear case using the special tools.

TOOLS:

Bearing remover, 35 mm

07936-3710400

Remover handle

07936-3710100

Remover weight

07741-0010201 or

07936-371020A or

07936-3710200

(U.S.A. only)

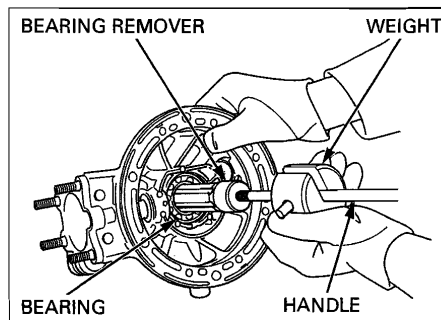

Remove the oil seal.

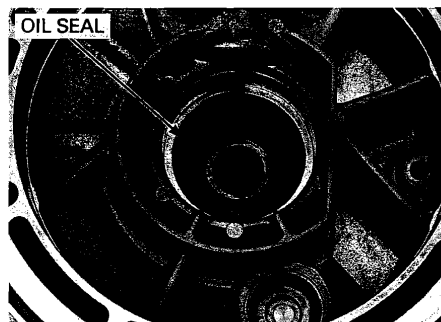

Remove the breather cap and blow compressed air through the hole.

Install the breather cap.

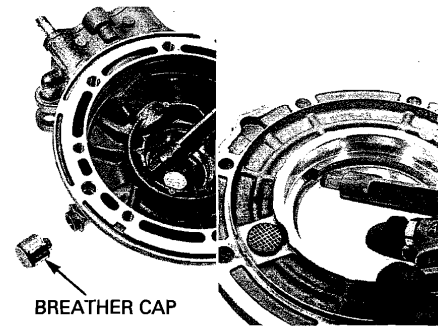

Apply grease to a new oil seal lips.
Drive the oil seal into the gear case with the marked side facing down until it is fully seated.

TOOLS:

Driver 07749-0010000
Attachment, 44 x 49.5 mm 07945-3330300

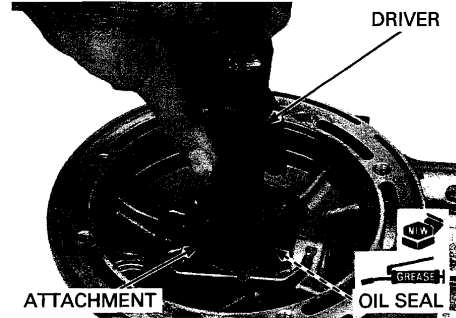

Drive a new ring gear case bearing into the gear case with the marked side facing inside until it is fully seated using the special tools.

TOOLS:

Driver 07749-0010000
Attachment, 52 x 55 mm 07746-0010400

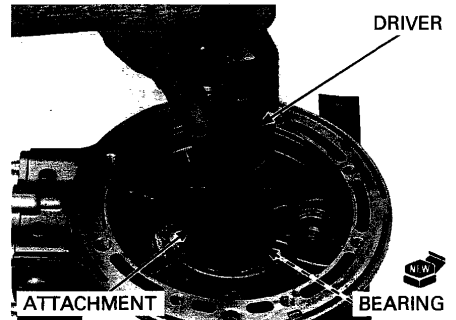

PINION NEEDLE BEARING

Rotate the stopper ring until the end of the stopper ring appears in the access hole.
Strike gently near the end of the ring with a punch to bend the end upward.
Grasp the end of the ring with needle-nose pliers and pull the stopper ring out through the access hole.

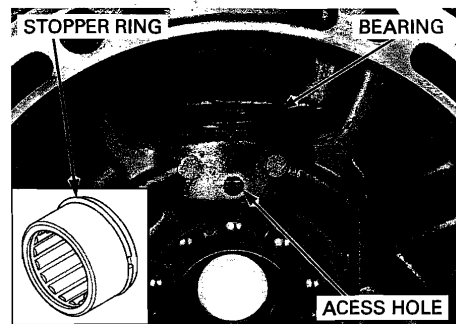

FINAL DRIVE

Be sure to wear heavy gloves when handling the heated gear case.

Heat the gear case to 80°C (176°F) and remove the needle bearing using the special tools.

TOOLS:

Bearing remover, 20 mm

07936-3710600 or equivalent commercially available in U.S.A.

07936-3710100

07741-0010201 or

07936-371020A or

07936-3710200

(U.S.A. only)

Remover handle

Remover weight

BEARING REMOVER

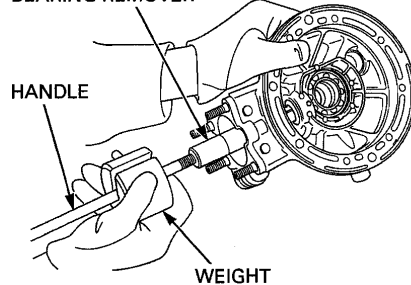

Install a new stopper ring into the groove of a new bearing securely.

STOPPER RING

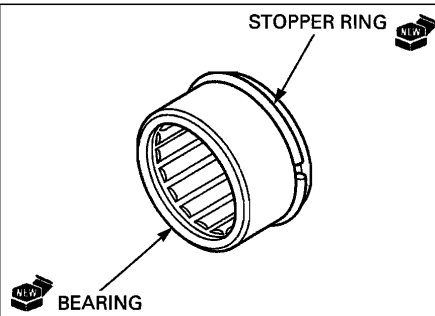

Place the needle bearing in a freezer.

Heat the gear case to 80°C (176°F).

Remove the needle bearing from the freezer and drive it into the gear case with the marked side facing up until it is fully seated.

TOOLS:

Driver

07749-0010000

Attachment, 32 x 35 mm

07746-0010100

Pilot, 19 mm

07746-0041400

DRIVER

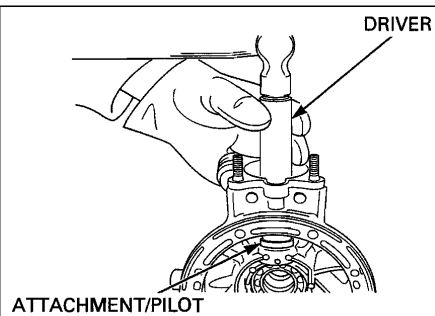

Make sure the stopper ring is securely set in the groove of the gear case.

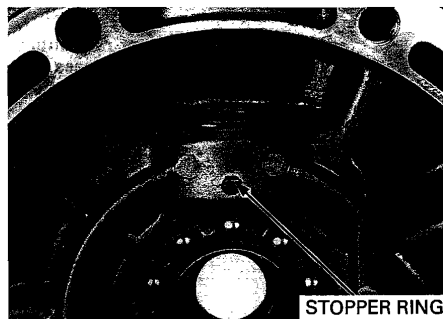

FINAL DRIVE ASSEMBLY

PINION GEAR INSTALLATION

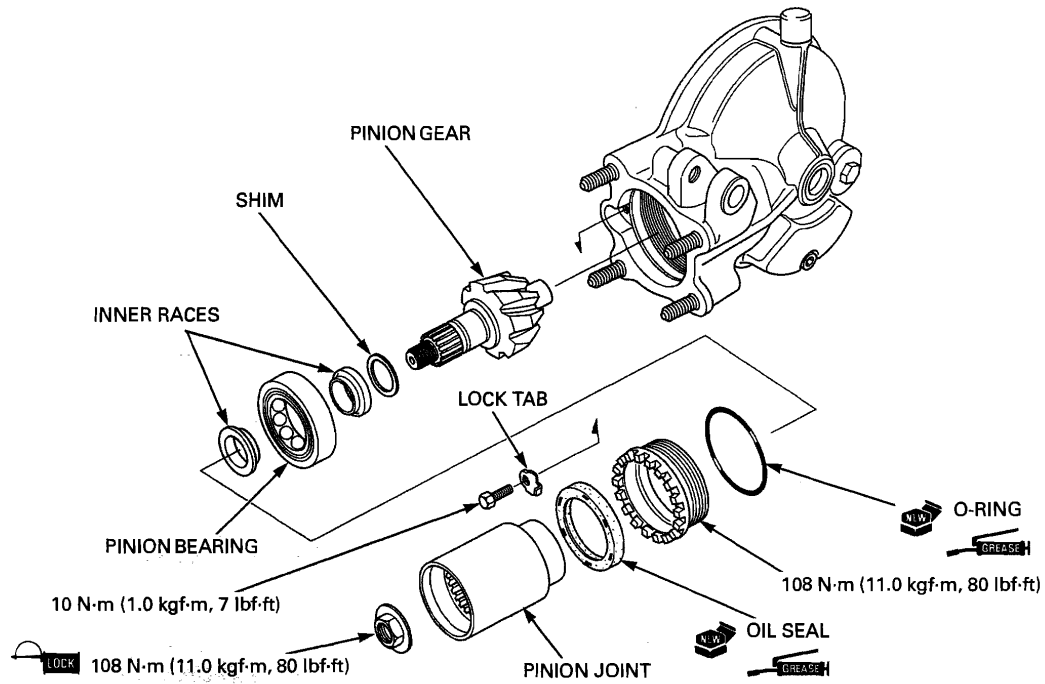

Drive the pinion gear assembly into the gear case using the special tool.

TOOL:
 Oil seal driver, 55.7 x 60.3 mm 07965-KE80200

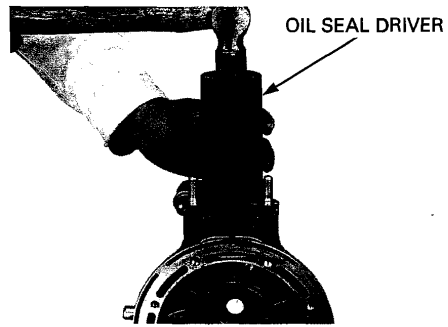

Apply grease to a new oil seal lips.
 Drive the oil seal into the pinion retainer with the marked side facing up until it is fully seated.

TOOLS:
 Driver 07749-0010000
 Attachment, 44 x 49.5 mm 07945-3330300

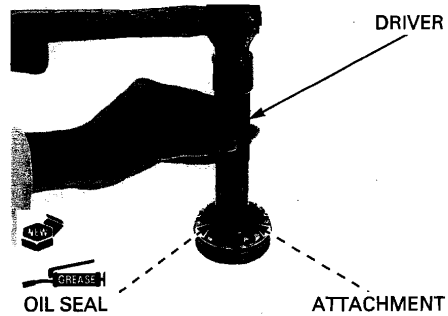

Pack grease into the seal lip cavity.

FINAL DRIVE

Coat a new O-ring with grease and install it into the retainer groove.

PINION RETAINER

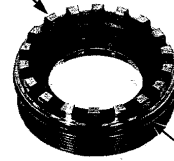

O-RING

Hold the gear case in a vise with soft jaws. Install the pinion retainer into the gear case and tighten it to the specified torque using a special tool.

TOOL:

Retainer wrench 07910-MA10100

TORQUE: 108 N·m (11.0 kgf·m, 80 lbf·ft)

RETAINER WRENCH

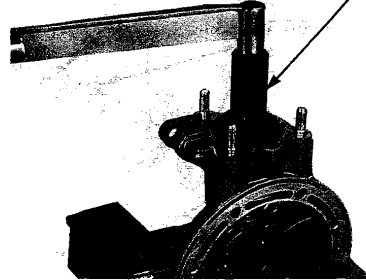

The lock tab is available in the two types (A and B) as shown.

Install the lock tab with its tab facing up, depending on the position of the pinion retainer grooves in relation to the lock tab and tighten the bolt.

TORQUE: 10 N·m (1.0 kgf·m, 7 lbf·ft)

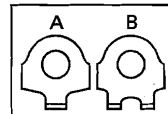

LOCK TAB

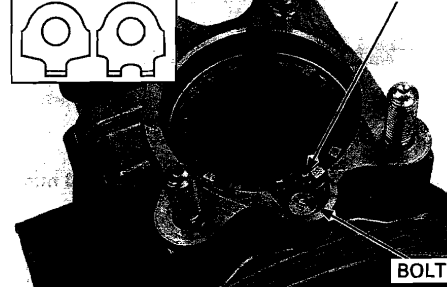

BOLT

Clean the threads of the pinion gear shaft and pinion joint nut thoroughly.

Apply locking agent to the joint nut threads and install the pinion joint and joint nut onto the pinion gear shaft.

JOINT NUT

LOCK

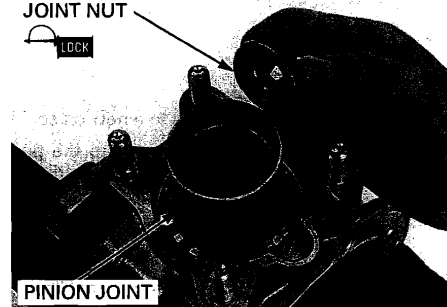

PINION JOINT

Hold the pinion joint with the special tools and tighten the pinion joint nut to the specified torque.

TOOLS:
 Pinion holder plate 07924-ME40010
 Collar set "C" 07924-ME40020

TORQUE: 108 N·m (11.0 kgf·m, 80 lbf·ft)

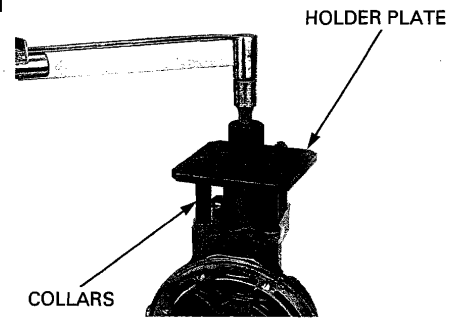

RING GEAR INSTALLATION

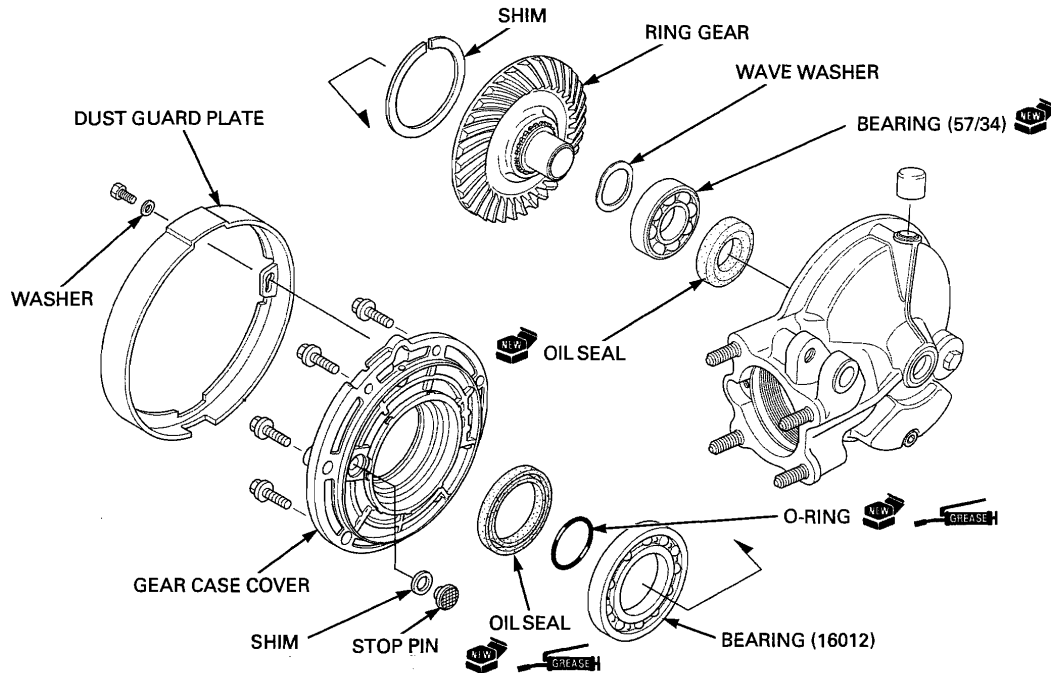

Install the shim onto the ring gear.
 Support the bearing inner race with the special tool and press the ring gear into the bearing using a hydraulic press.

TOOL:
 Oil seal driver 070MF-MEG0300

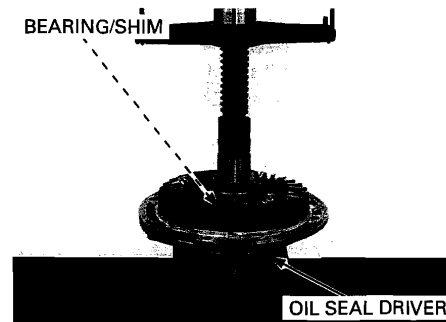

FINAL DRIVE

Measure the clearance between the ring gear and stop pin with a feeler gauge.

CLEARANCE: 0.30 – 0.60 mm (0.012 – 0.024 in)

Remove the ring gear if the clearance does not fall within the specification.

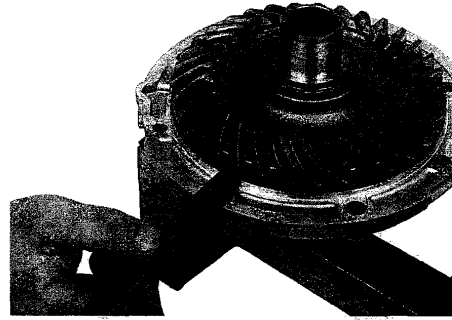

Be sure to wear heavy gloves when handling the heated gear case.

Heat the gear case cover to approximately 80°C (176°F). Heat the case cover evenly and slowly to prevent warpage.

When the gear case cover is heated to the proper temperature, remove the stop pin by tapping the cover.

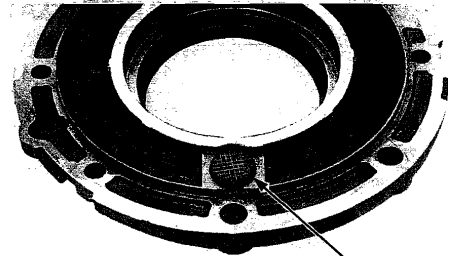

STOP PIN

Select a stop pin shim to obtain the correct clearance.

**SHIM THICKNESS: A: 0.10 mm (0.004 in)
B: 0.15 mm (0.006 in)**

Install the shim and drive the stop pin into the gear case cover.

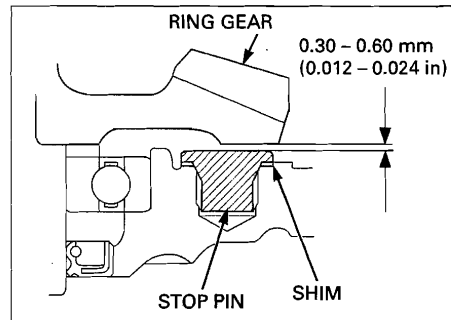

Apply grease to a new oil seal lips.

Install the oil seal until it is flush with the cover surface using the special tools.

TOOLS:

Driver
Oil seal driver
Attachment, 72 x 75 mm

07749-0010000
070MF-MEG0300
07746-0010600

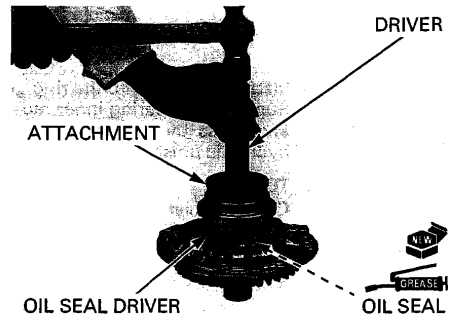

FINAL GEAR CASE ASSEMBLY

NOTE:

When the gear set, bearing and/or gear case has been replaced, check the tooth contact pattern (page 14-9) and gear case backlash (page 14-8).

Keep dust and dirt out of the case and cover.

Clean the mating surface of the gear case and cover, being careful not to damage them.

Apply liquid sealant to the mating surface of the gear case.

Install the wave washer.

Install the case cover onto the gear case.

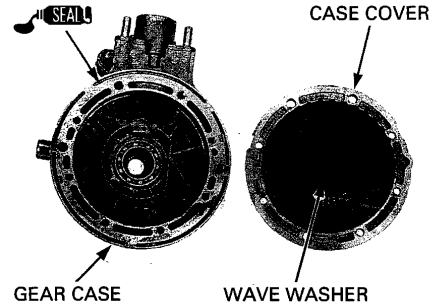

Apply locking agent to the threads of the case cover 10 mm bolts.

Install the bolts, and tighten them in a crisscross pattern in several steps until the cover evenly touches the gear case.

Tighten the two 10 mm bolts to the specified torque in several steps alternately.

TORQUE: 47 N-m (4.8 kgf-m, 35 lbf-ft)

Tighten the six 8 mm bolts to the specified torque in a crisscross pattern in several steps.

TORQUE: 25 N-m (2.5 kgf-m, 18 lbf-ft)

Apply grease to a new O-ring.

Install the O-ring in the ring gear groove.

Check that the gear assembly turns smoothly without binding.

Measure the final gear assembly pre-load.

STANDARD:

0.2 – 0.4 N-m (2 – 4 kgf-cm, 0.1 – 0.3 lbf-ft)

If the preload reading does not fall within the specification, check the bearings for proper installation.

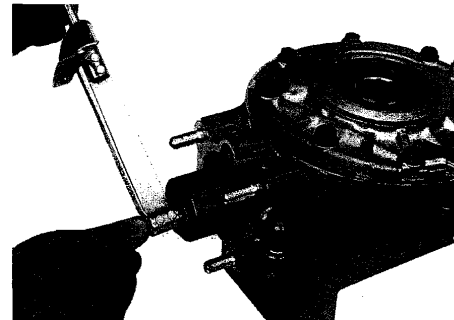
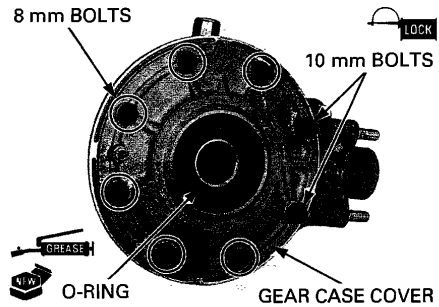

FINAL DRIVE

Install the dust guard plate, aligning its tabs with the cover grooves.

Turn the dust guard plate counterclockwise and install the bolt and washer.

Tighten the bolt to the specified torque.

TORQUE: 10 N·m (1.0 kgf·m, 7 lbf·ft)

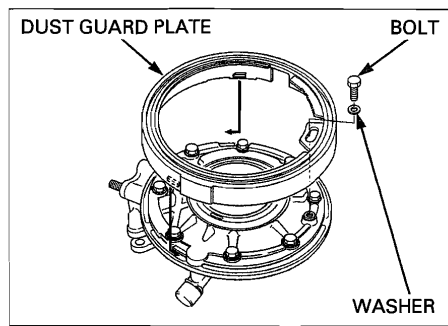

FINAL DRIVE INSTALLATION

Check that the gear case stud bolts are tight. If any are loose, remove them, clean their threads with contact cleaner, then install them using a locking agent.

After installation, be sure to measure the distance from the top of each stud to the gear case surface as shown.

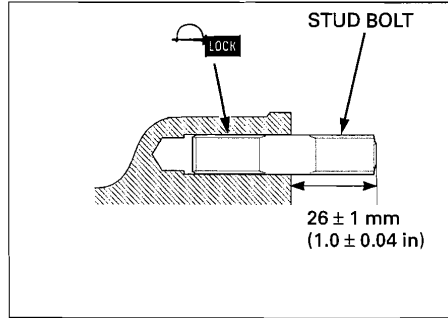

Install a new stopper ring into the drive shaft groove.

Install the spring into the drive shaft.

Apply 0.5 g of molybdenum disulfide grease to a new oil seal lips and install it onto the drive shaft.

Apply 1 g of molybdenum disulfide grease to the universal joint side splines of the drive shaft.

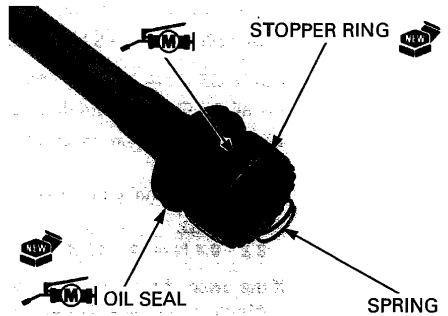

Apply 2 g or more of molybdenum disulfide grease to the pinion joint splines.

Make sure the stopper ring is seated properly by pulling on the drive shaft lightly. Be careful not to damage the drive shaft oil seal.

Install the drive shaft into the pinion joint until the stopper ring seats in the pinion joint spline groove.

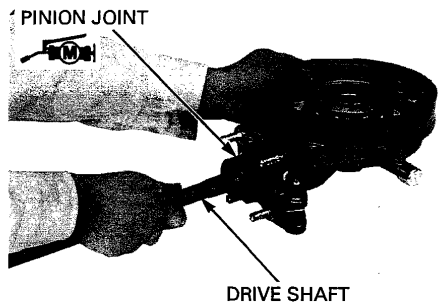

Insert the final drive assembly into the swingarm and align the drive shaft splines with the universal joint splines.

Install the gear case mounting nuts.

Tighten the gear case mounting nuts in a crisscross pattern in several steps.

TORQUE: 64 N·m (6.5 kgf·m, 47 lbf·ft)

Tighten the shock absorber lower mounting bolt to the specified torque.

TORQUE: 22 N·m (2.2 kgf·m, 16 lbf·ft)

Install the rear wheel (page 16-13).

Fill the gear case with the recommended final drive gear oil (page 4-18).

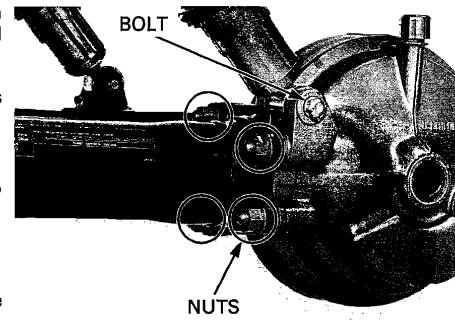

15. FRONT WHEEL/SUSPENSION/STEERING

COMPONENT LOCATION	15-2	FRONT WHEEL	15-13
SERVICE INFORMATION	15-3	FORK	15-19
TROUBLESHOOTING	15-5	STEERING STEM.....	15-28
HANDLEBAR	15-6		

FRONT WHEEL/SUSPENSION/STEERING

COMPONENT LOCATION

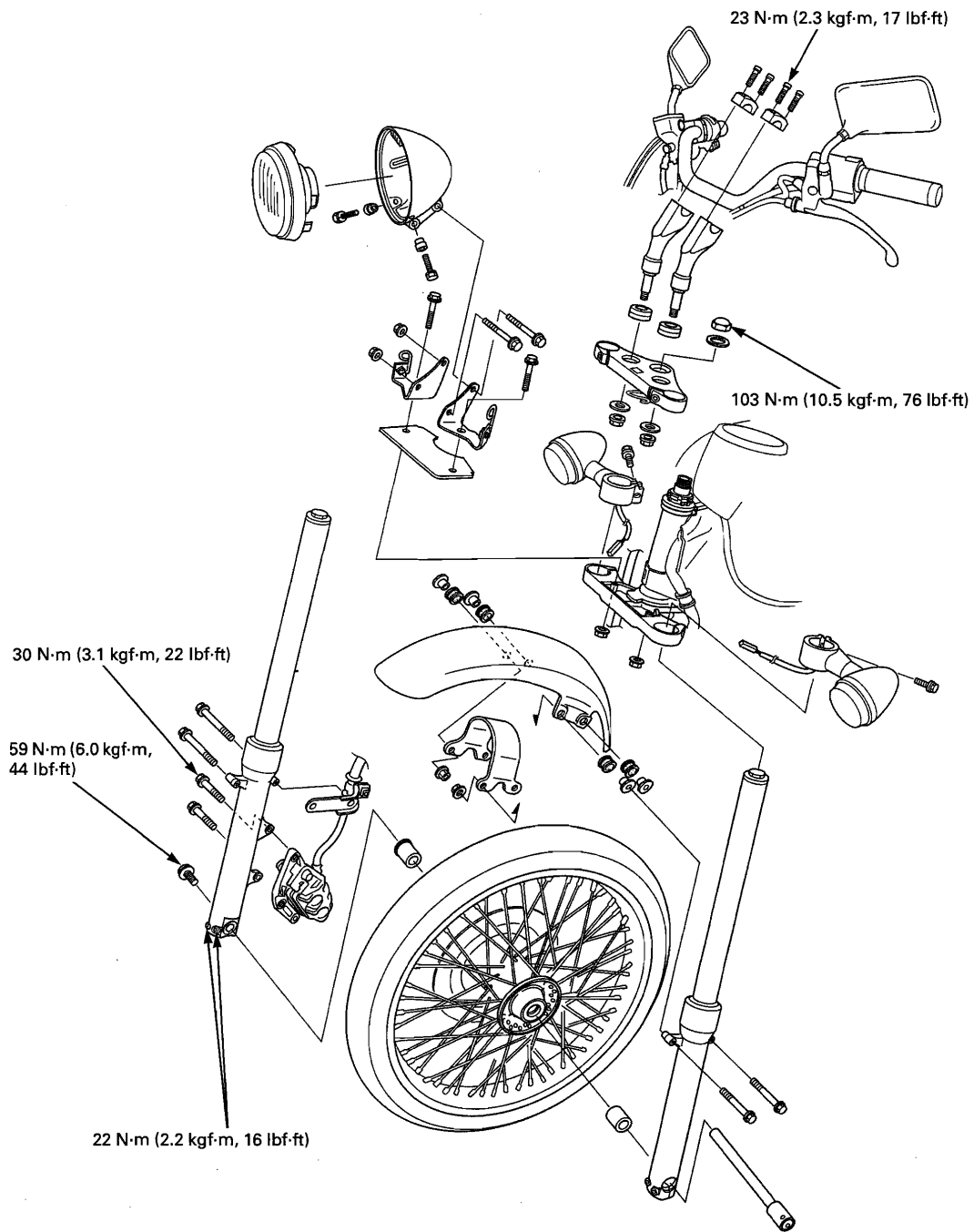

SERVICE INFORMATION**GENERAL**

- Riding on damaged rims impairs safe operation of the vehicle.
- A contaminated brake disc or pad reduces stopping power. Discard contaminated pads and clean a contaminated disc with a high quality brake degreasing agent.
- A hoist or equivalent is required to support the motorcycle when servicing the front wheel, fork and steering stem.
- For hydraulic brake system service (page 17-2).

SPECIFICATIONS

ITEM		STANDARD	SERVICE LIMIT
Minimum tire tread depth		–	1.5 (0.06)
Cold tire pressure	Up to 90 kg (200 lbs) load	200 kPa (2.00 kgf/cm ² , 29 psi)	–
	Up to maximum weight capacity	200 kPa (2.00 kgf/cm ² , 29 psi)	–
Axle runout		–	0.2 (0.01)
Wheel rim runout	Radial	–	2.0 (0.08)
	Axial	–	2.0 (0.08)
Wheel balance weight		–	60 g max.
Fork	Spring free length	371.8 (14.64)	364.4 (14.35)
	Tube runout	–	0.2 (0.01)
	Recommended fork fluid	Pro Honda Suspension Fluid SS-8 (10W)	–
	Fluid level	100 (3.9)	–
	Fluid capacity	478 ± 2.5 cm ³ (16.2 ± 0.08 US oz, 16.8 ± 0.09 Imp oz)	–
Steering head bearing pre-load		8.5 – 12.7 N (0.9 – 1.3 kgf)	–



Unit: mm (in)

TORQUE VALUES

Handlebar upper holder bolt	23 N·m (2.3 kgf·m, 17 lbf·ft)	
Handlebar lower holder nut	23 N·m (2.3 kgf·m, 17 lbf·ft)	
Front master cylinder holder bolt	12 N·m (1.2 kgf·m, 9 lbf·ft)	
Front brake disc bolt	42 N·m (4.3 kgf·m, 31 lbf·ft)	ALOC bolt; replace with a new one
Spoke	4.2 N·m (0.4 kgf·m, 3.1 lbf·ft)	
Front axle bolt	59 N·m (6.0 kgf·m, 44 lbf·ft)	
Front axle pinch bolt	22 N·m (2.2 kgf·m, 16 lbf·ft)	
Fork center socket bolt	29.5 N·m (3.0 kgf·m, 22 lbf·ft)	Apply locking agent to the threads
Fork cap	22.1 N·m (2.3 kgf·m, 16 lbf·ft)	
Fork top bridge pinch bolt	22 N·m (2.2 kgf·m, 16 lbf·ft)	
Fork bottom bridge pinch bolt	49 N·m (5.0 kgf·m, 36 lbf·ft)	
Front brake caliper mounting bolt	30 N·m (3.1 kgf·m, 22 lbf·ft)	ALOC bolt; replace with a new one
Steering top thread	See page 15-32	
Steering top thread lock nut	See page 15-32	
Steering stem nut	103 N·m (10.5 kgf·m, 76 lbf·ft)	
Clutch lever pivot bolt	1 N·m (0.1 kgf·m, 0.7 lbf·ft)	
Clutch lever pivot nut	6 N·m (0.6 kgf·m, 4.4 lbf·ft)	

FRONT WHEEL/SUSPENSION/STEERING

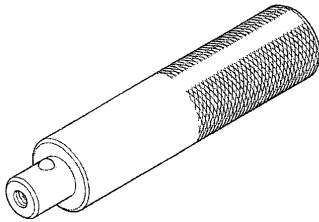
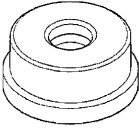
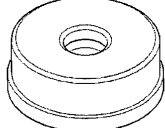
TOOLS

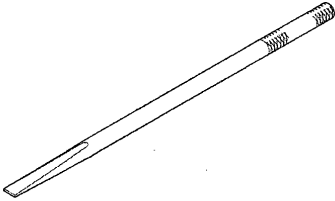
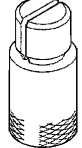
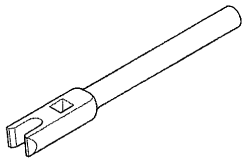
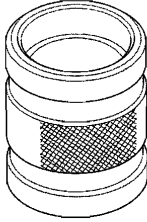
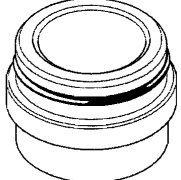
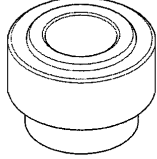
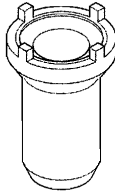
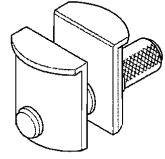
<p>Driver 07749-0010000</p> 	<p>Attachment, 42 x 47 mm 07746-0010300</p> 	<p>Attachment, 52 x 55 mm 07746-0010400</p> 
<p>Pilot, 20 mm 07746-0040500</p> 	<p>Bearing remover shaft 07GGD-0010100</p> 	<p>Bearing remover head, 20 mm 07746-0050600</p> 
<p>Spoke wrench 07JMA-MR60100</p> 	<p>Slider weight 07947-KA50100</p> 	<p>Driver attachment 07947-KF00100</p> 
<p>Attachment, 30 mm I.D. 07746-0030300</p> 	<p>Steering stem socket 07916-3710101 or 07916-3710100 (U.S.A. only)</p> 	<p>Bearing remover 07946-3710500</p> 

Ball race remover set
07953-MJ10000

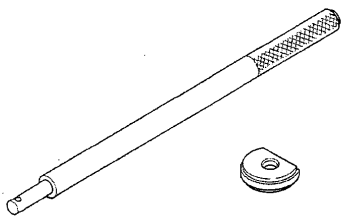

or 07953-MJ1000B (U.S.A. only)

TROUBLESHOOTING

Hard steering

- Steering top thread too tight
- Worn or damaged steering head bearings
- Bent steering stem
- Insufficient tire pressure
- Faulty tire

Steers to one side or does not track straight

- Bent fork leg
- Damaged steering head bearings
- Loose steering top thread
- Bent frame
- Worn wheel bearings
- Bent front axle
- Worn swingarm pivot components (page 16-22)

Front wheel wobbles

- Bent rim
- Worn wheel bearings
- Faulty tire
- Unbalanced tire and wheel
- Axle fastener not tightened properly

Wheel hard to turn

- Faulty wheel bearings
- Bent axle
- Brake drag (page 17-4)

Soft suspension

- Weak fork spring
- Low fluid level in fork
- Insufficient fluid weight (low viscosity)
- Low tire pressure

Stiff suspension

- High tire pressure
- Bent fork tube
- Fork slider binds
- High fluid level in fork leg
- Incorrect fluid weight (high viscosity)
- Clogged fork fluid passage

Front suspension noise

- Loose fork fasteners
- Insufficient fluid weight (low viscosity)
- Worn slider or fork tube bushing

HANDLEBAR

REMOVAL

Remove the rearview mirrors.

Release the handlebar switch wires from the wire clips.

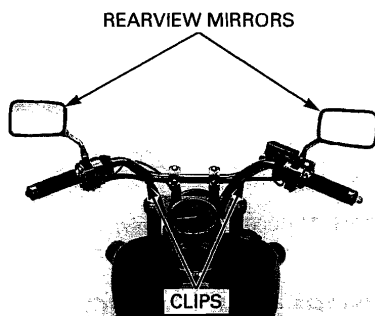

Remove the pivot bolt, nut and clutch lever from the clutch lever bracket.

Disconnect the clutch switch connectors from the clutch switch.

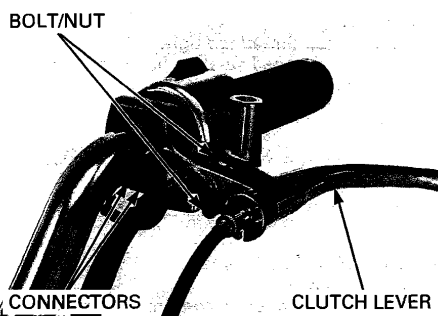

Remove the bolts, holder and clutch lever bracket.

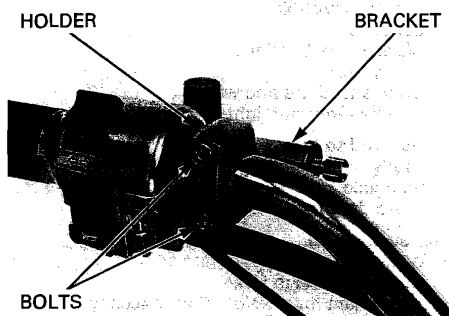

Remove the clutch switch from the clutch lever bracket.

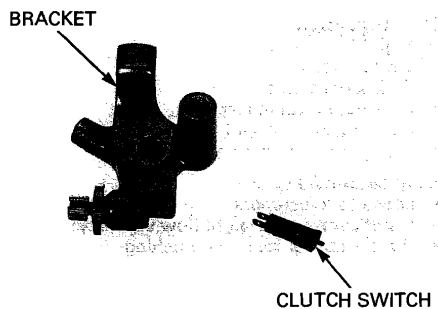

Remove the screws and left handlebar switch housing.
Remove the left handlebar grip and housing cap.

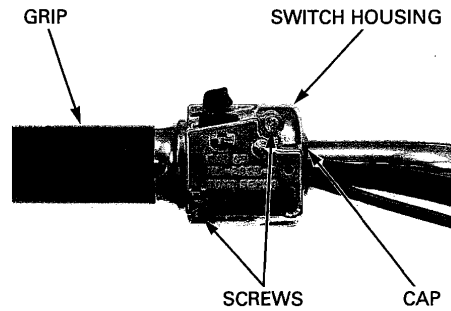

Disconnect the front brake light switch wire connectors from the switch.
Remove the bolts, holder and master cylinder assembly.

Keep the reservoir upright to prevent air from entering the hydraulic system.

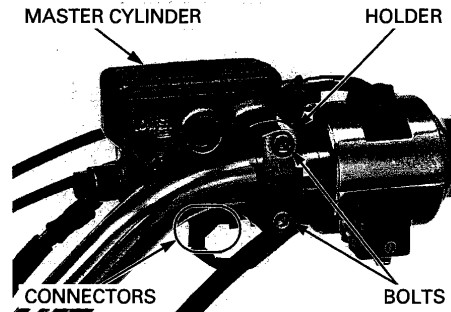

Remove the right handlebar switch/throttle housing screws.

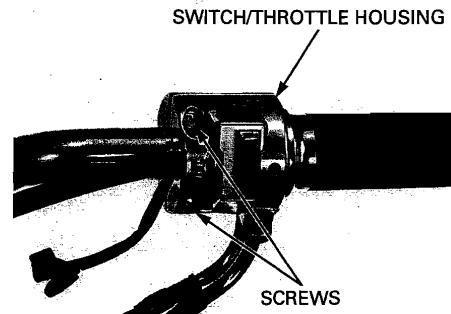

Disconnect the throttle cables from the throttle pipe and remove the throttle grip from the right handlebar.
Remove the right handlebar switch/throttle housing from the handlebar.

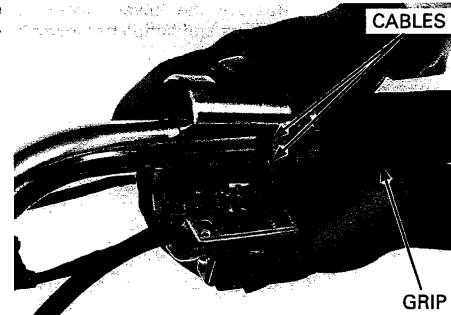

FRONT WHEEL/SUSPENSION/STEERING

Loosen the handlebar lower holder nuts.

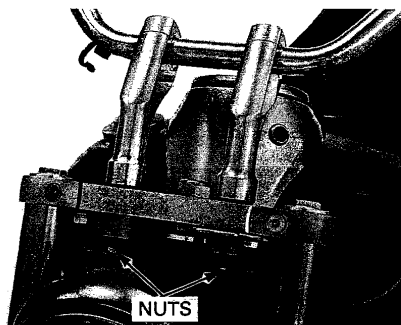

Remove the bolt caps.

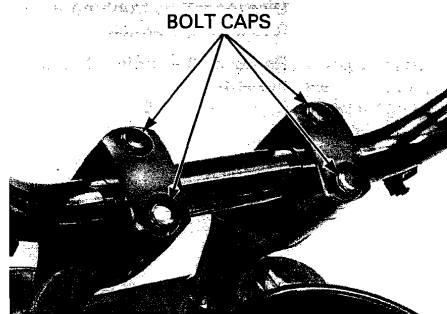

Remove the bolts, upper holders and handlebar.

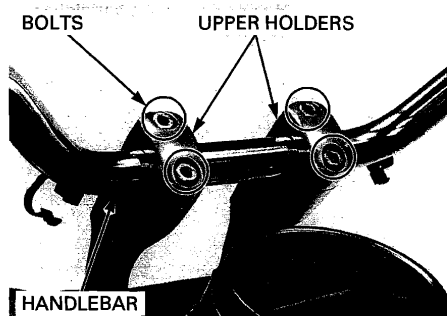

Remove the lower holder nuts, washers, setting rubbers and handlebar lower holders.

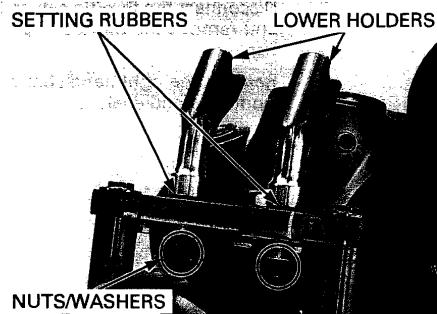

INSTALLATION

NOTE:

- Route the cable, hose and wires properly (page 1-22).

Check the bushings for abnormal wear or damage.

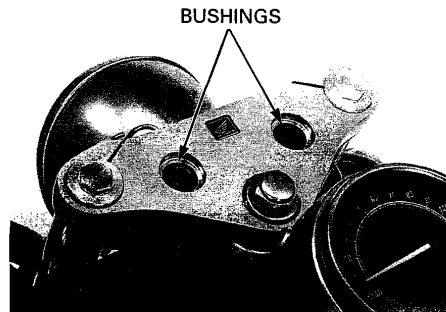

Install the setting rubbers onto the top bridge with its small I.D. side facing up as shown.

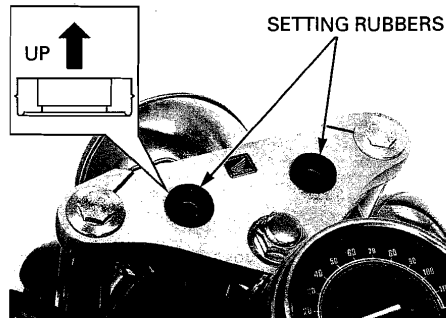

Install the handlebar lower holders, washers and nuts onto the top bridge.

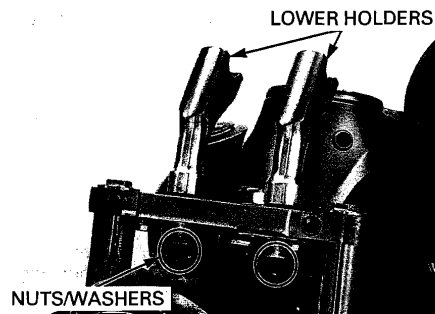

Place the handlebar on the lower holders aligning the punch mark on the handlebar with the top surface of the lower holders. Install the upper holders with its punch mark facing forward.

Tighten the front side bolts first, then the rear side bolts to the specified torque.

TORQUE: 23 N·m (2.3 kgf·m, 17 lbf·ft)

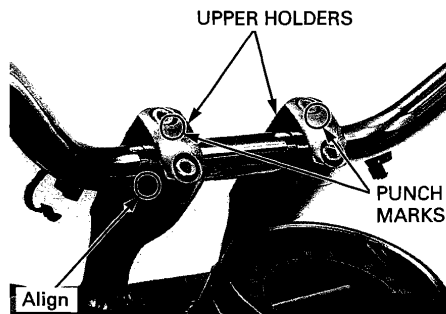

FRONT WHEEL/SUSPENSION/STEERING

Tighten the handlebar lower holder nuts to the specified torque.

TORQUE: 23 N·m (2.3 kgf·m, 17 lbf·ft)

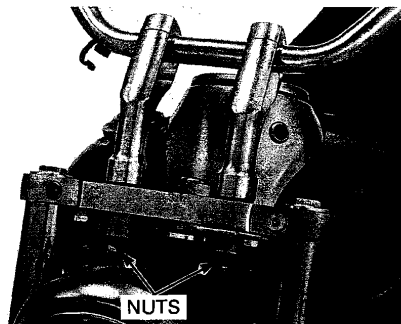

INNER WEIGHT REMOVAL/INSTALLATION

Remove the grip or throttle pipe from the handlebar.
Straighten the weight retainer tabs by the screwdriver or punch.

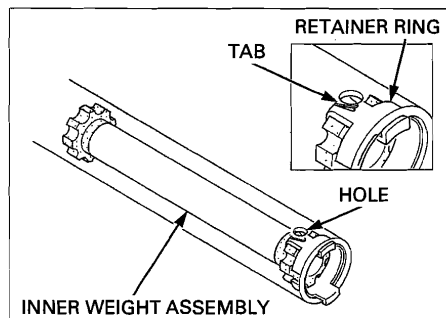

Remove the inner weight assembly from the handlebar.
Discard the retainer ring.
Check the rubber cushions for wear or damage.
Install a new retainer ring onto the inner weight.

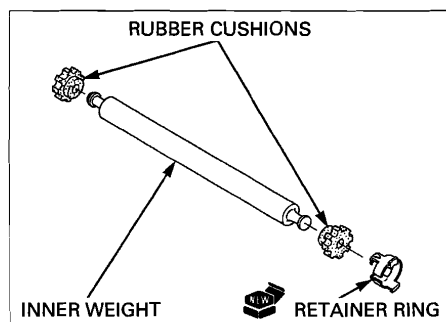

Insert the inner weight assembly into the handlebar
by hooking the retainer ring tabs with the holes in
the handlebar.

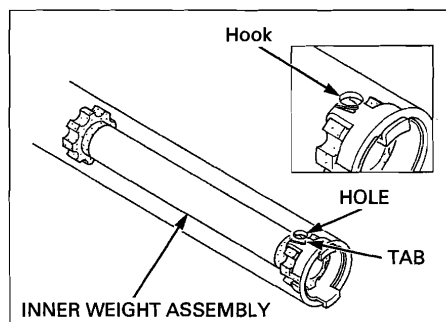

Install the housing cap onto the left side of the handlebar.

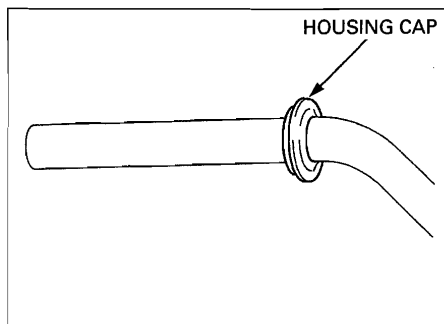

Clean the inside surface of the handlebar grip and the outside surface of the handlebar and throttle pipe. Apply Pro Honda Handgrip Cement or equivalent to the inside surface of the handlebar grip and to the outside surface of the handlebar and throttle pipe. Wait 3 – 5 minutes and install the grip.

Allow the adhesive to dry for 1 hour before using.

Rotate the grip for even application of the adhesive.

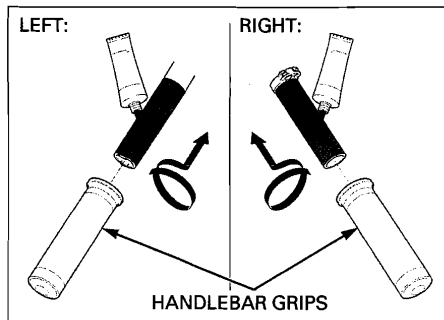

Apply grease 0.2 – 0.3 g to the throttle pipe flange groove and sliding surface.

Install the throttle pipe onto the handlebar.

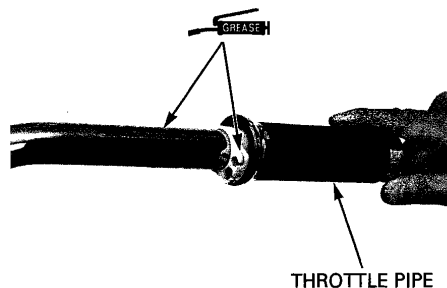

Connect the throttle cables to the throttle pipe flange.

Install the right handlebar switch/throttle housing with the two screws, aligning the locating pin with the hole in the handlebar.

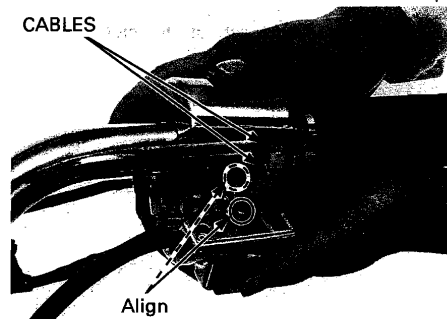

FRONT WHEEL/SUSPENSION/STEERING

Tighten the front long screw first, then tighten the rear short screw.

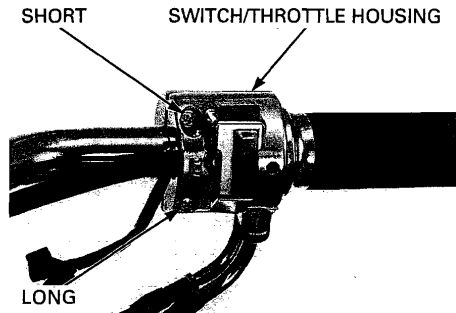

Install the holder with its "UP" mark facing up.

Install the master cylinder, holder and bolts. Align the edge of the master cylinder with the punch mark on the handlebar and tighten the upper bolt first, then tighten the lower bolt.

TORQUE: 12 N·m (1.2 kgf·m, 9 lbf·ft)

Connect the front brake light switch connectors.

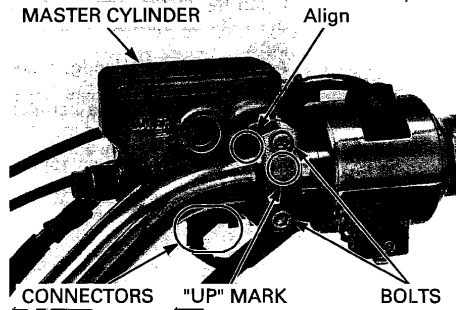

Set the housing cap flange into the housing groove.

Install the left handlebar switch housing and screws, aligning the locating pin with the hole in the handlebar. Tighten the front short screw first, then tighten the rear long screw.

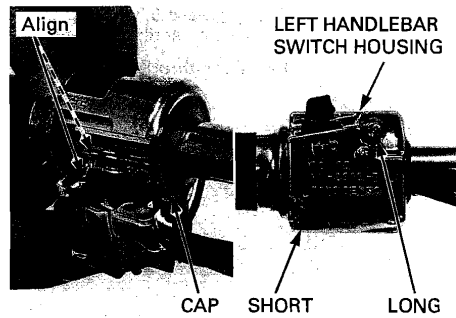

Install the clutch switch into the bracket, aligning the tab of the clutch switch and groove of the bracket.

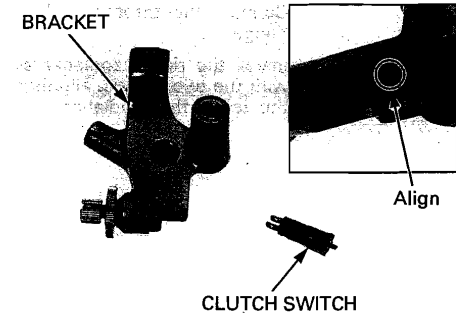

Install the holder with its "UP" mark facing up.

Install the clutch lever bracket, holder and bolts. Align the edge of the bracket with the punch mark on the handlebar and tighten the upper bolt first, then tighten the lower bolt securely.

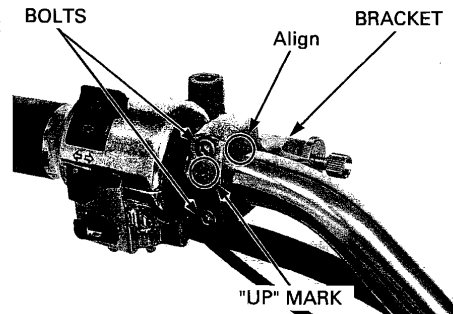

Apply grease to the clutch lever pivot bolt sliding surface.

Connect the clutch switch connectors. Connect the clutch cable on the clutch lever.

Install the clutch lever onto the bracket and tighten the clutch lever pivot bolt to the specified torque.

TORQUE: 1 N·m (0.1 kgf·m, 0.7 lbf·ft)

Tighten the nut to the specified torque while holding the pivot bolt.

TORQUE: 6 N·m (0.6 kgf·m, 4.4 lbf·ft)

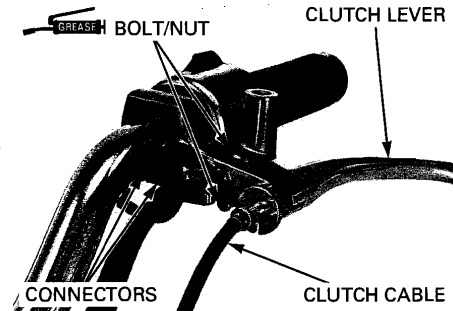

Install the wire clips onto the tabs on the handlebar. Secure the switch wires with the wire clips.

Install the rearview mirrors.

Adjust the clutch lever freeplay (page 4-23).

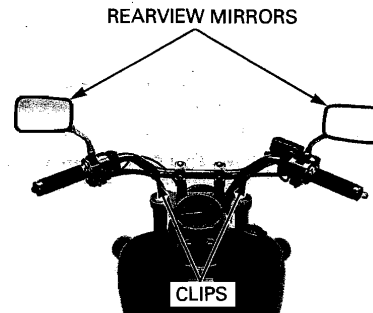

FRONT WHEEL

REMOVAL

Remove the axle bolt and loosen the right axle pinch bolts.

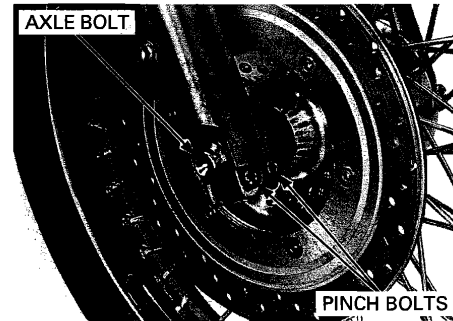

FRONT WHEEL/SUSPENSION/STEERING

Loosen the left axle pinch bolts.

Support the motorcycle securely and raise the front wheel off the ground.

Remove the axle and front wheel.

Do not operate the brake lever after removing the wheel. To do so will cause difficulty in fitting the brake disc between the brake pads.

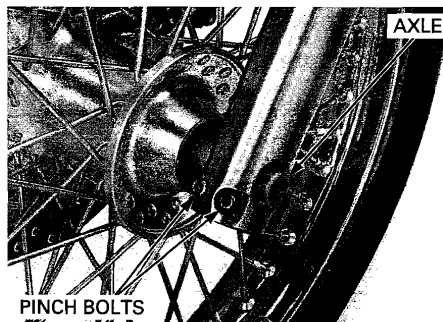

Remove the side collars.

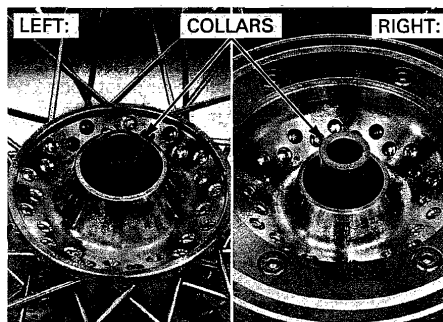

INSPECTION

AXLE

Set the axle in V-blocks.
Turn the axle and measure the runout using a dial indicator.

Actual runout is 1/2 the total indicator reading.

SERVICE LIMIT: 0.2 mm (0.01 in)

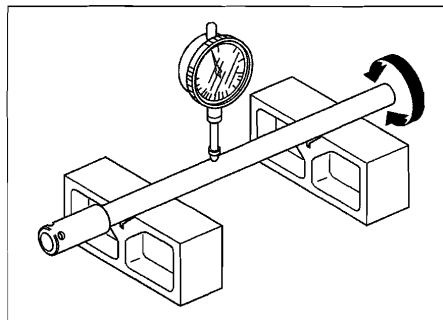

WHEEL RIM

Check the rim runout by placing the wheel in a truing stand.

Spin the wheel slowly and read the runout using a dial indicator.

Actual runout is 1/2 the total indicator reading.

SERVICE LIMITS:

Radial: 2.0 mm (0.08 in)

Axial: 2.0 mm (0.08 in)

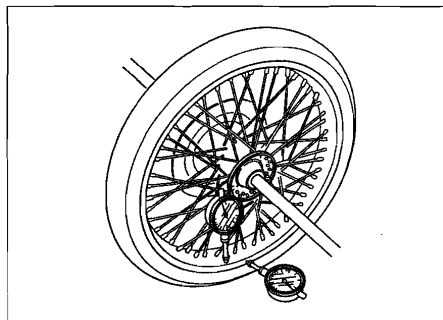

WHEEL BEARING

Turn the inner race of each bearing with your finger. The bearings should turn smoothly and quietly. Also check that the bearing outer race fits tightly in the hub.

Replace the wheel bearings in pairs.

Remove and discard the bearings if the races do not turn smoothly and quietly, or if they fit loosely in the hub (page 15-15).

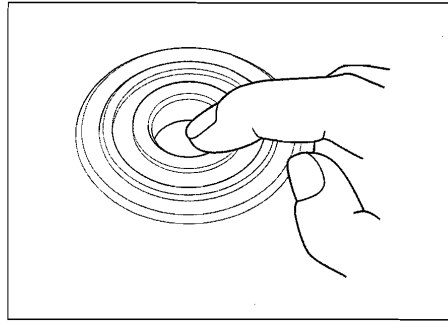

DISASSEMBLY

Remove the dust seals from both sides of the hub.

Do not reuse the bolts.

Remove the bolts in a crisscross pattern in several steps and remove the brake disc.

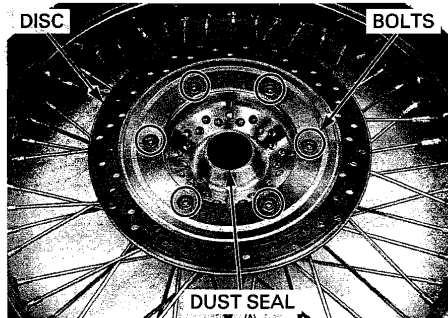

Replace the wheel bearings in pairs. Do not reuse old bearing.

Install the remover head into the bearing. From the opposite side of the wheel, install the remover shaft and drive the bearing out of the wheel hub. Remove the distance collar and drive out the other bearing.

TOOLS:

- Bearing remover shaft 07GGD-0010100
- Bearing remover head, 20 mm 07746-0050600

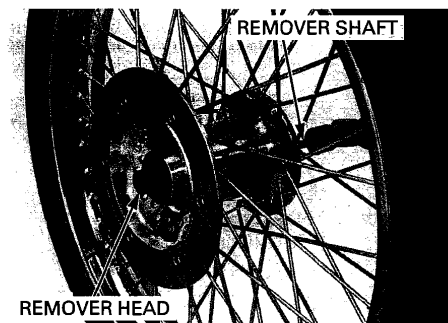

FRONT WHEEL/SUSPENSION/STEERING

ASSEMBLY

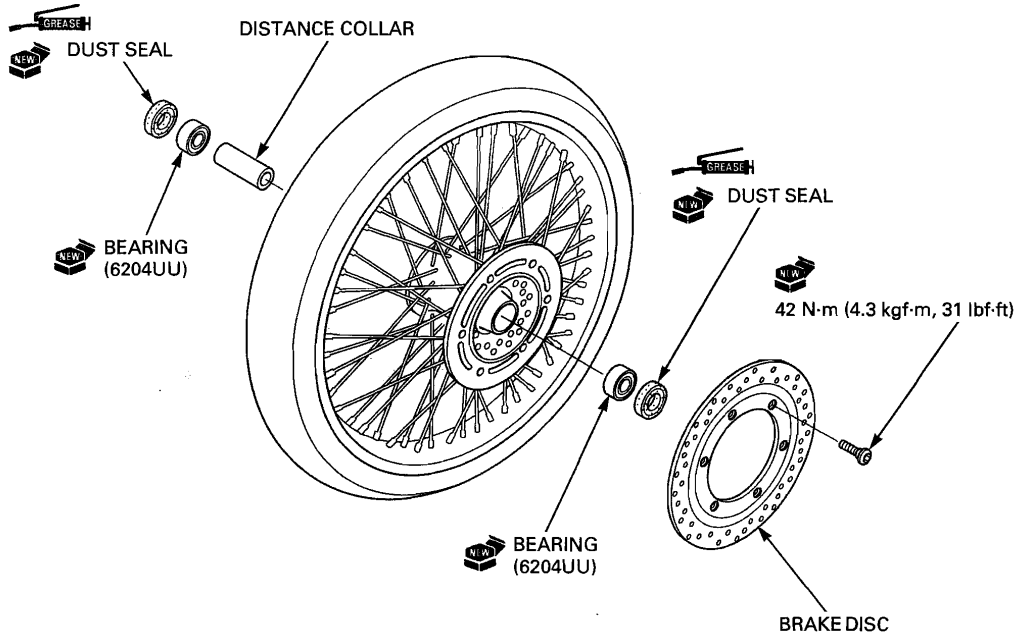

Drive in a new left bearing squarely with the marked side facing up until it is fully seated.

Install the distance collar.

Drive in a new right bearing squarely with the marked side facing up until it is seated on the collar.

TOOLS:

Driver	07749-0010000
Attachment, 42 x 47 mm	07746-0010300
Pilot, 20 mm	07746-0040500

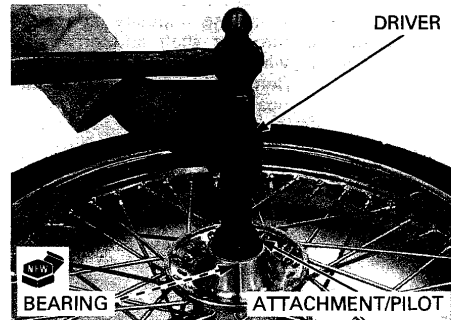

WHEEL CENTER ADJUSTMENT

Measure the distance B (rim width) and calculate distance A as follows:

$$A = 79 \text{ mm (3.11 in)} - B/2$$

Adjust the rim position and distance A by tightening the spokes to the specified torque in several progressive steps.

TOOL:

Spoke wrench	07JMA-MR60100
--------------	---------------

TORQUE: 4.2 N-m (0.4 kgf-m, 3.1 lbf-ft)

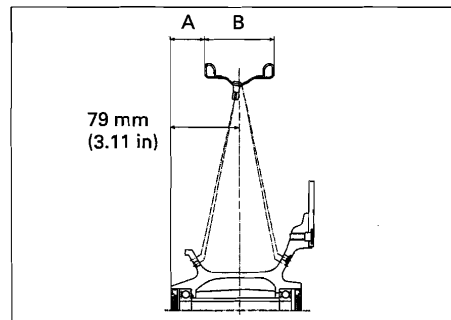

Do not get grease on the brake disc or stopping power will be reduced.

Install the brake disc with the marked side facing out.

Install new bolts and tighten them in a crisscross pattern in several steps.

TORQUE: 42 N-m (4.3 kgf-m, 31 lbf-ft)

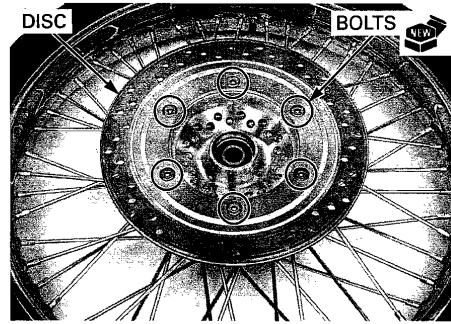

WHEEL BALANCE

NOTE:

- Carefully check balance before installing the wheel.
- Mount the tire with the arrow mark facing in the direction of rotation.
- The wheel balance must be checked when the tire is remounted.
- For optimum balance, the tire balance mark (light mass point: a paint dot on the side wall) must be located next to the valve stem. Remount the tire if necessary.

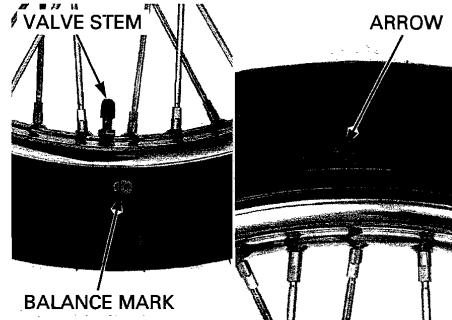

Mount the wheel, tire and brake disc assembly on an inspection stand.
Spin the wheel, allow it to stop, and mark the lowest (heaviest) part of the wheel with chalk.
Do this two or three times to verify the heaviest area.
If the wheel is balanced, it will not stop consistently in the same position.

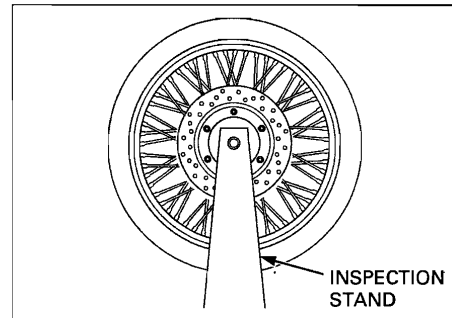

To balance the wheel, install a new balance weight on the lightest side of the spoke, on the side opposite the chalk marks. Add just enough weight so the wheel will no longer stop in the same position when it is spun.
Do not add more than 60 g to the front wheel.

NOTE:

Never reuse the balance weight if once removed from the spoke.

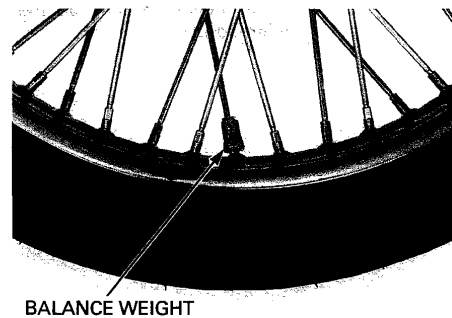

FRONT WHEEL/SUSPENSION/STEERING

Apply grease to new dust seal lips and install the dust seals until they are flush with the wheel hub.

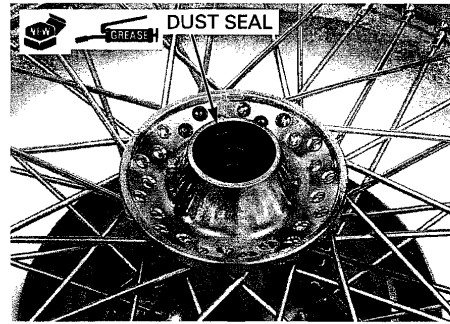

INSTALLATION

Install the right side (disc side) collar with its flange side facing out.

Install the side collars.

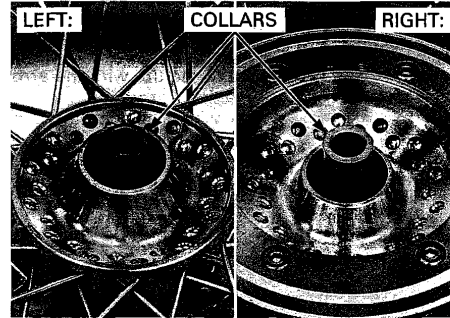

Be careful not to damage the pads.

Place the front wheel between the fork legs so the brake disc is positioned between the brake pads.

Apply thin coat of grease to the axle sliding surface. Insert the axle from the left side. Tighten the axle bolt to the specified torque.

TORQUE: 59 N·m (6.0 kgf·m, 44 lbf·ft)

Tighten the right axle pinch bolts to the specified torque.

TORQUE: 22 N·m (2.2 kgf·m, 16 lbf·ft)

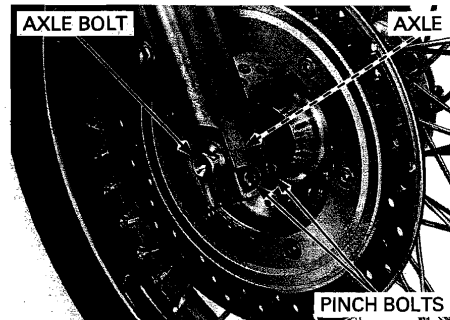

With the front brake applied, pump the forks up and down several times to seat the axle and check brake operation.

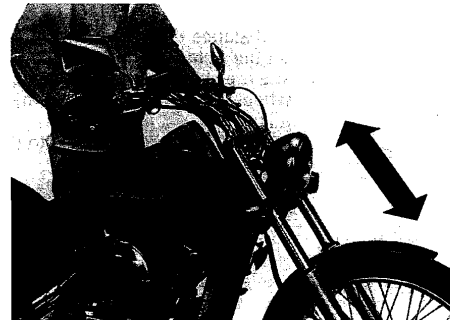

Tighten the left axle pinch bolts to the specified torque.

TORQUE: 22 N·m (2.2 kgf·m, 16 lbf·ft)

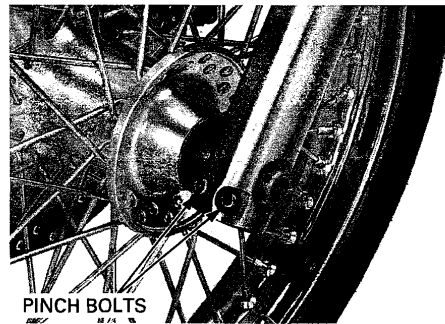

PINCH BOLTS

FORK

REMOVAL

Remove the following:

- Front wheel (page 15-13)
- Front fender (page 3-6)

*Right fork only:
Do not reuse
caliper mounting
bolts.*

Remove the bolts and brake caliper assembly.

NOTE:

Support the brake caliper so it does not hang from the brake hose.

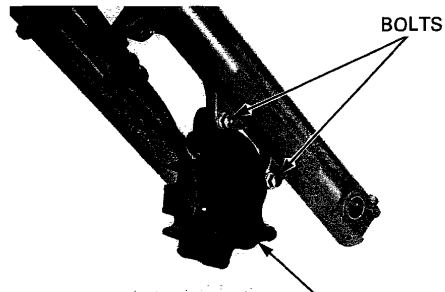

BOLTS

BRAKE CALIPER ASSEMBLY

Loosen the top bridge pinch bolt. When the fork will be disassembled. Loosen the fork cap but do not remove yet.

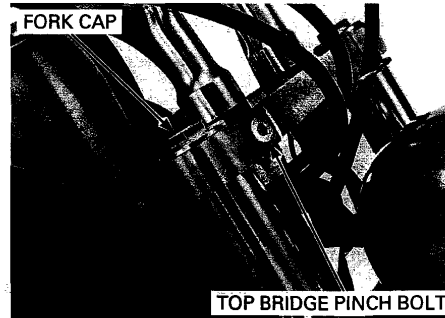

FORK CAP

TOP BRIDGE PINCH BOLT

Remove the bolt, collar and turn signal light.

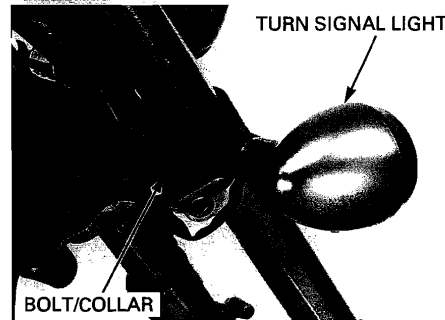

TURN SIGNAL LIGHT

BOLT/COLLAR

FRONT WHEEL/SUSPENSION/STEERING

Loosen the bottom bridge pinch bolt, then remove the fork leg.

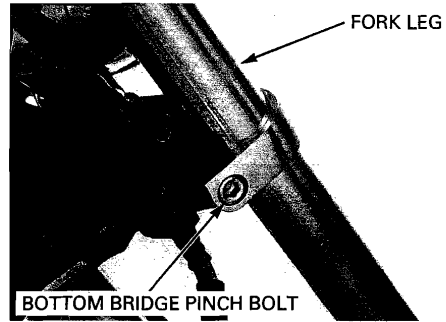

DISASSEMBLY

Remove the dust seal.

Do not scratch the fork tube sliding surface.

Remove the oil seal stopper ring.

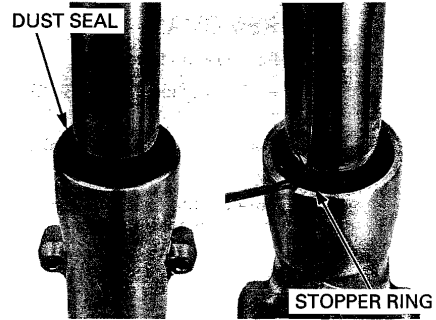

The fork cap is under spring pressure; use care when loosening it.

Remove the fork cap and O-ring.

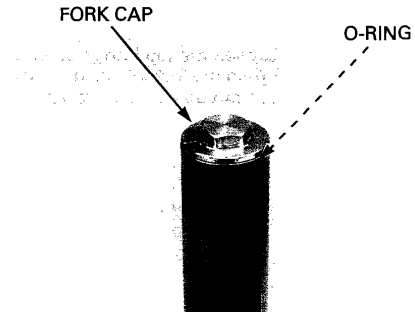

Remove the spacer and spring seat.

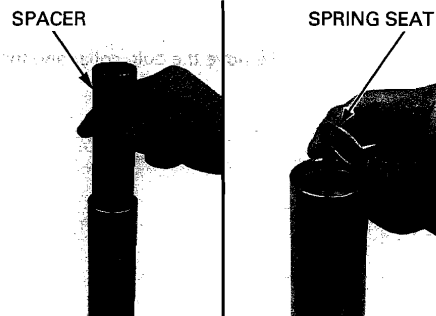

Remove the fork spring from the fork tube.
Pour out the fork fluid by pumping the fork tube several times.

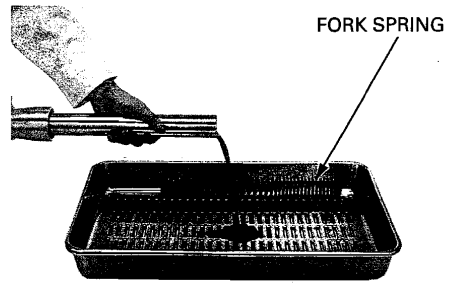

Do not over-tighten the vise on the fork slider.

If the fork piston turns with the fork center socket bolt, temporarily install the fork spring, spring seat, spacer and fork cap.

Hold the fork slider in a vise with soft jaws.
Remove the fork center socket bolt and sealing washer.

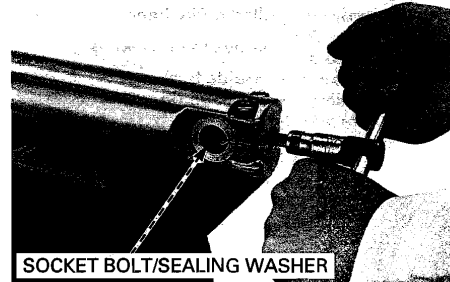

Do not remove the fork piston ring, unless it is necessary to replace with a new one.

Remove the fork piston and rebound spring.

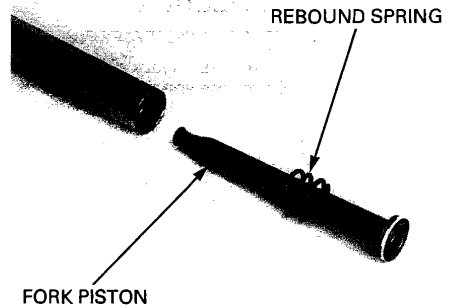

Using quick successive motions, pull the fork tube out of the fork slider.

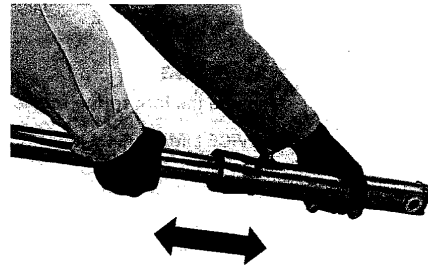

FRONT WHEEL/SUSPENSION/STEERING

Remove the spring and oil lock piece from the fork slider.

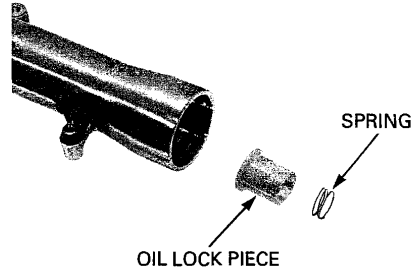

Do not damage the slider bushing, especially the sliding surface. To prevent loss of tension, do not open the bushing more than necessary.

Carefully remove the slider bushing by prying the slot with a screwdriver until the bushing can be pulled off by hand.

Remove the following:

- Guide bushing
- Back-up ring
- Oil seal

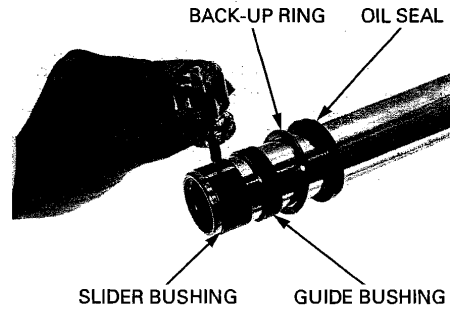

INSPECTION

OIL LOCK PIECE/SPRING

Check the oil lock piece for wear or damage.
Check the spring for fatigue or damage.

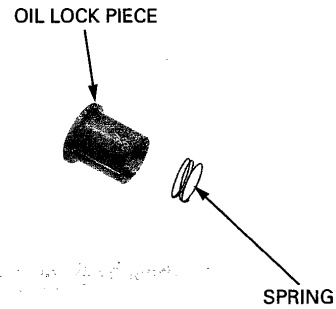

FORK SPRING

Measure the fork spring free length.

SERVICE LIMIT: 364.4 mm (14.35 in)

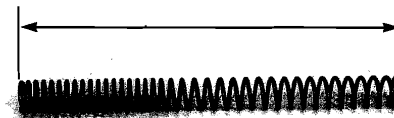

FORK TUBE/SLIDER/PISTON

Check the fork tube and fork slider for score marks, and excessive or abnormal wear.

Replace any damaged component if necessary.

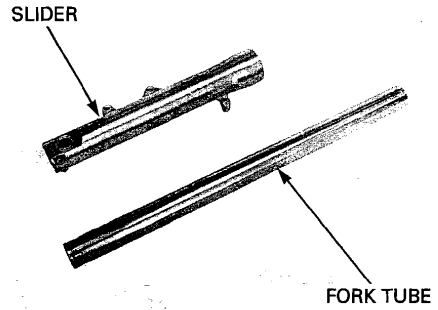

Check the fork piston for score marks, and excessive or abnormal wear.

Check the fork piston ring for wear or damage.
Check the rebound spring for fatigue or damage.

Replace any damaged component if necessary.

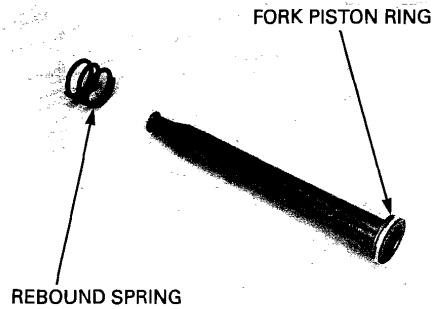

Set the fork tube in V-blocks and measure the fork tube runout with a dial indicator.
Actual runout is 1/2 the total indicator reading.

SERVICE LIMIT: 0.2 mm (0.01 in)

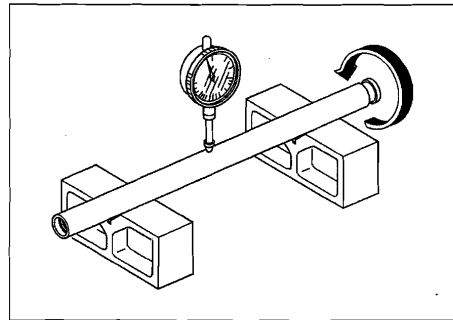

Visually inspect the slider and guide bushings.
Replace the bushings if there is excessive scoring or scratching, or if the teflon is worn so the copper surface appears on more than 3/4 of the entire surface.

Check the back-up ring; replace it if there is any distortion at the points shown.

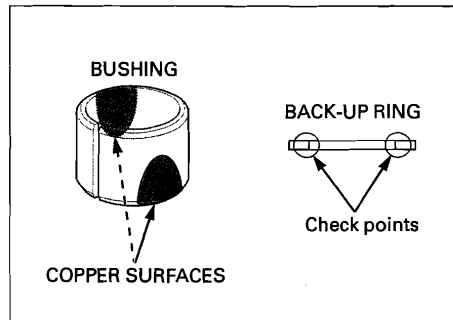

FRONT WHEEL/SUSPENSION/STEERING

ASSEMBLY

Before assembly, wash all parts with a high flash point or non-flammable solvent and wipe them off completely.

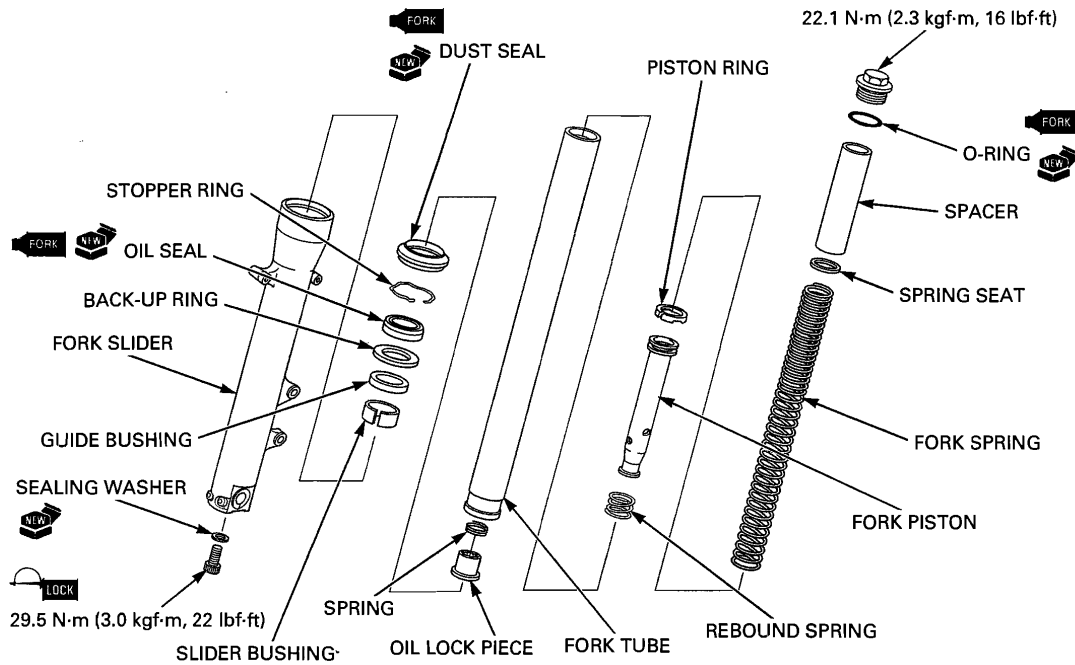

Do not open the bushing slit more than necessary.

Install the slider bushing being careful not to damage the coating of the bushing, if it has been removed.
Remove the burrs from the bushing mating surface, being careful not to peel off the coating.

Install the oil seal with its marked side facing up.

Apply fork fluid to the new oil seal lips.
Install the guide bushing, back-up ring and new oil seal onto the fork tube.

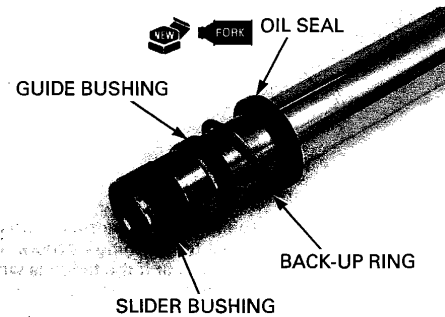

Install the rebound spring to the fork piston, then install them into the fork tube.
If the piston ring is removed, install a new piston ring into the fork piston groove.

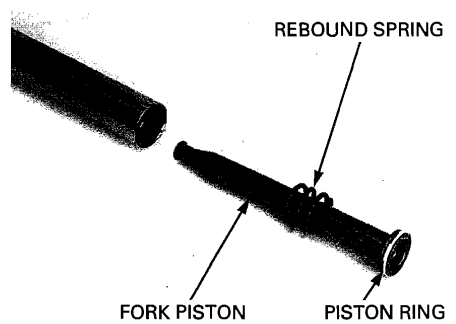

Install the oil lock piece and spring to the fork piston end.
Install the fork tube assembly into the fork slider.

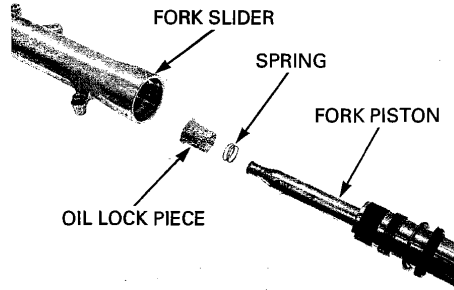

Do not over-tighten the vise on the fork slider.

Hold the fork slider in a vise with soft jaws.
Apply locking agent to the fork center socket bolt threads.
Install the socket bolt with a new sealing washer.

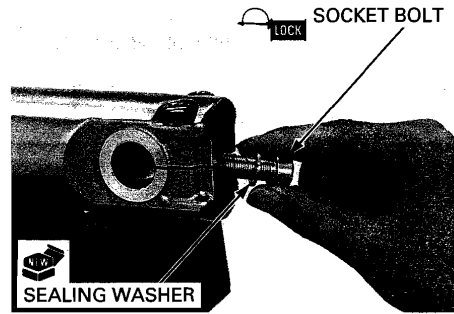

If the fork piston turns with the fork center socket bolt, temporarily install the fork spring, spring seat, spacer and fork cap.

Tighten the fork center socket bolt to the specified torque.
TORQUE: 29.5 N-m (3.0 kgf-m, 22 lbf-ft)

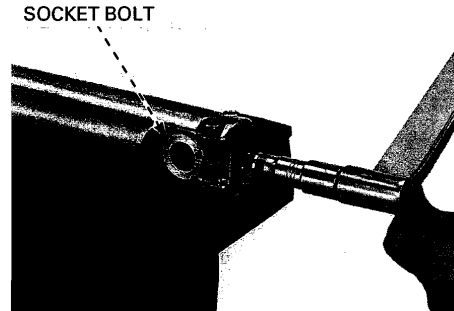

Drive the oil seal until the stopper ring groove is visible using the special tools.

TOOLS:
Slider weight
Driver attachment

07947-KA50100
07947-KF00100

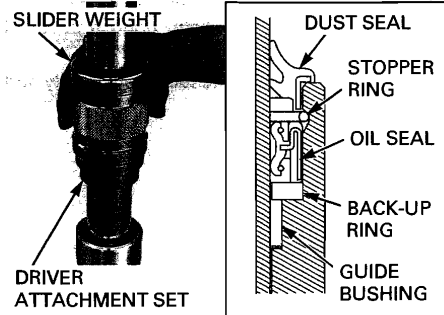

FRONT WHEEL/SUSPENSION/STEERING

Pour the specified amount of the recommended fork fluid into the fork tube.

RECOMMENDED FORK FLUID:
Pro Honda Suspension Fluid SS-8 (10W)

FORK FLUID CAPACITY:
 $478 \pm 2.5 \text{ cm}^3$ (16.2 \pm 0.08 US oz, 16.8 \pm 0.09 Imp oz)

Slowly pump the fork tube several times to remove any trapped air from the lower portion of the fork tube.

Compress the fork tube fully. Measure the fluid level from the top of the fork tube.

FORK FLUID LEVEL: 100 mm (3.9 in)

Pull the fork tube up and install the fork spring with the tightly wound coil side facing up.

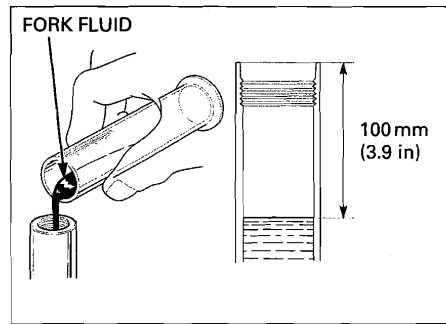

FORK SPRING



Install the spring seat and spacer.

SPRING SEAT



SPACER



Coat a new O-ring with fork fluid and install it into the fork cap groove.

Be careful not to cross-thread the fork cap. Tighten the fork cap after installing the fork leg into the steering stem and top bridge.

Hold the fork cap securely and install it into the fork tube.

FORK CAP



Install the stopper ring into the groove into the fork slider, being careful not to scratch the fork tube sliding surface.

Coat a new dust seal lips with fork fluid and install it.

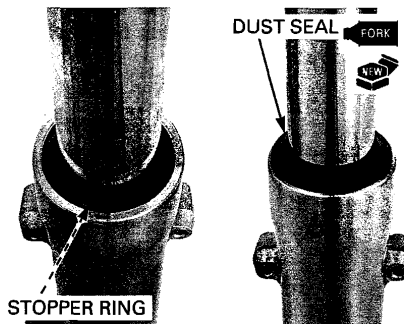

INSTALLATION

Install the fork leg into the steering stem and top bridge.

Align the fork tube top end surface with the top bridge as shown.

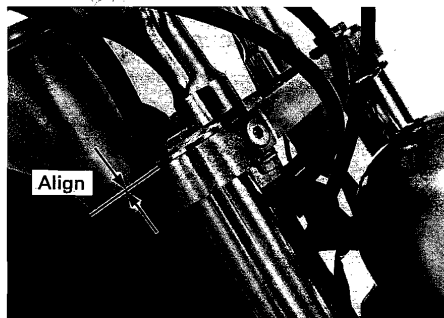

Tighten the bottom bridge pinch bolts to the specified torque.

TORQUE: 49 N-m (5.0 kgf-m, 36 lbf-ft)

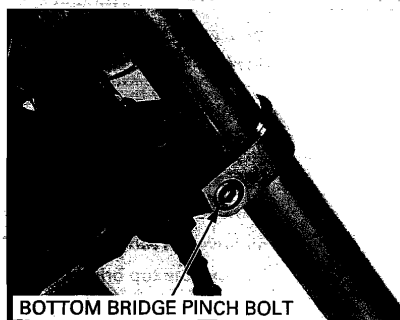

Install the turn signal light, collar and bolt. Tighten the bolt securely.

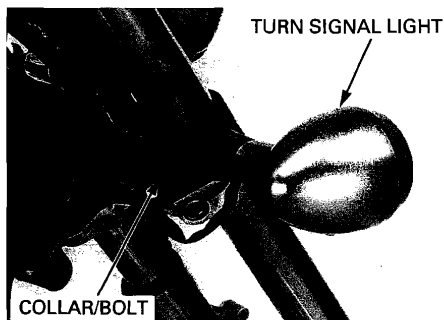

FRONT WHEEL/SUSPENSION/STEERING

Tighten the top bridge pinch bolt to the specified torque.

TORQUE: 22 N·m (2.2 kgf·m, 16 lbf·ft)

Tighten the fork cap to the specified torque.

TORQUE: 22.1 N·m (2.3 kgf·m, 16 lbf·ft)

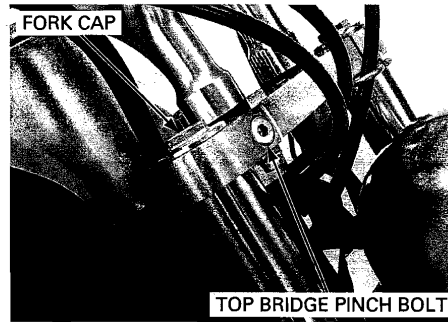

Right fork only: Install the brake caliper with new mounting bolts and tighten the bolts.

TORQUE: 30 N·m (3.1 kgf·m, 22 lbf·ft)

Install the following:

- Front fender (page 3-6)
- Front wheel (page 15-18)

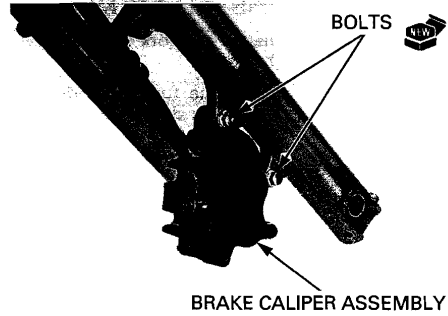

STEERING STEM

REMOVAL

Remove the following:

- Handlebar (page 15-6)
- Front wheel (page 15-13)
- Front fender (page 3-6)
- Headlight case (page 21-5)
- Turn signal light (page 21-6)

Remove the steering stem nut and washer.

Remove the fork legs (page 15-19).

Remove the top bridge.

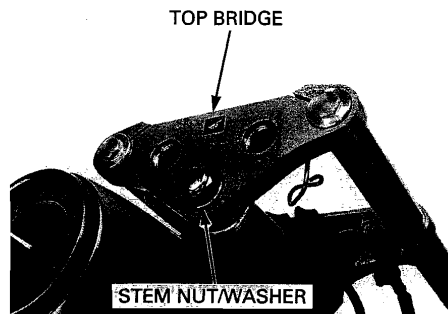

Remove the bolt and front brake hose.

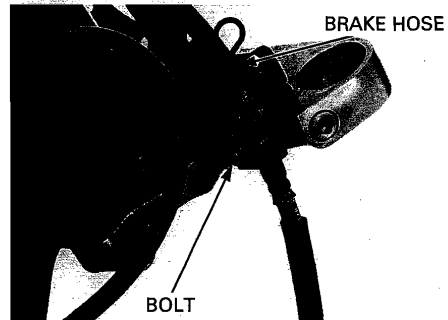

Remove the bolts, nuts, headlight case brackets and steering stem cover.

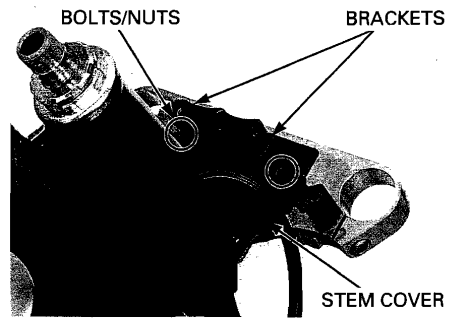

Straighten the lock washer tabs.

Remove the steering top thread lock nut and lock washer.

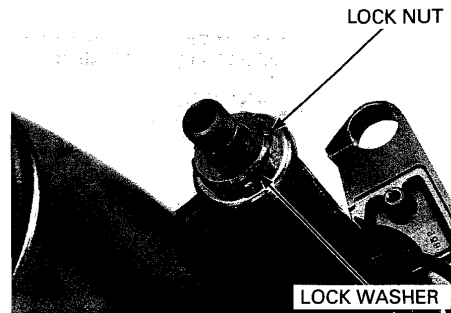

Loosen the steering top thread using the special tool.

TOOL:

Steering stem socket

**07916-3710101 or
07916-3710100
(U.S.A only)**

While holding the steering stem, remove the steering top thread.

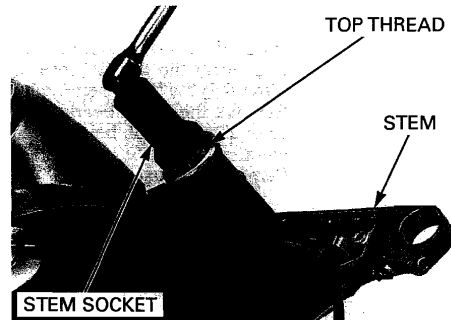

Remove the following:

- Steering stem
- Dust seal
- Upper inner race
- Upper steering head bearing
- Lower steering head bearing

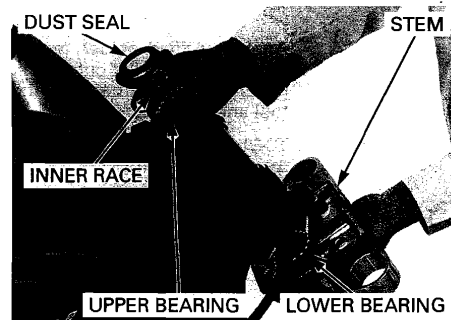

BEARING REPLACEMENT

Remove the upper bearing outer race using the special tools.

TOOLS:

- Ball race remover set** 07953-MJ10000
- Remover attachment 07946-MJ10100
- Driver shaft 07946-MJ10200 or 07953-MJ1000B (U.S.A. only)

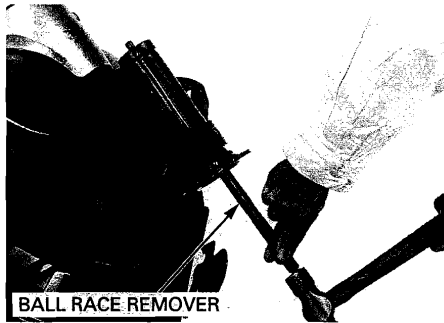

Remove the lower bearing outer race using the special tool and suitable shaft.

TOOL:

- Bearing remover** 07946-3710500



Install the steering stem nut onto the steering stem to prevent the threads from being damaged when removing the lower bearing inner race.

Remove the lower bearing inner race with a chisel or equivalent tool, being careful not to damage the stem.

Remove the dust seal.

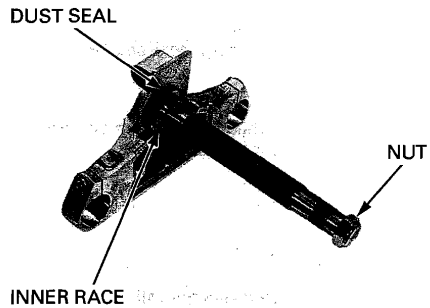

Apply specified grease (page 1-19) to a new dust seal lip and install it onto the steering stem. Press a new lower bearing inner race using a special tool and hydraulic press.

TOOL:

- Attachment, 30 mm I.D.** 07746-0030300

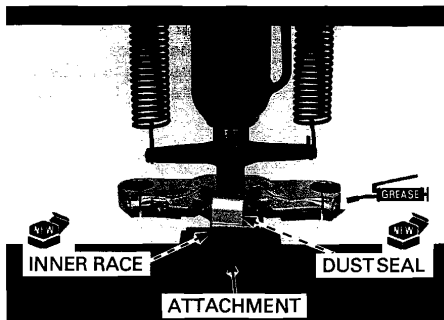

Drive in a new upper bearing outer race into the steering head pipe using the special tools.

TOOLS:

Driver 07749-0010000
Attachment, 42 x 47 mm 07746-0010300

Drive in a new lower bearing outer race into steering head pipe using the special tools.

TOOLS:

Driver 07749-0010000
Attachment, 52 x 55 mm 07746-0010400

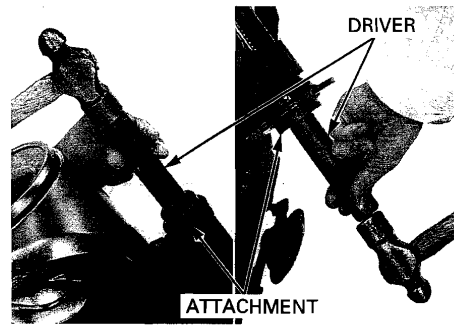

INSTALLATION

HEADLIGHT CASE BRACKETS

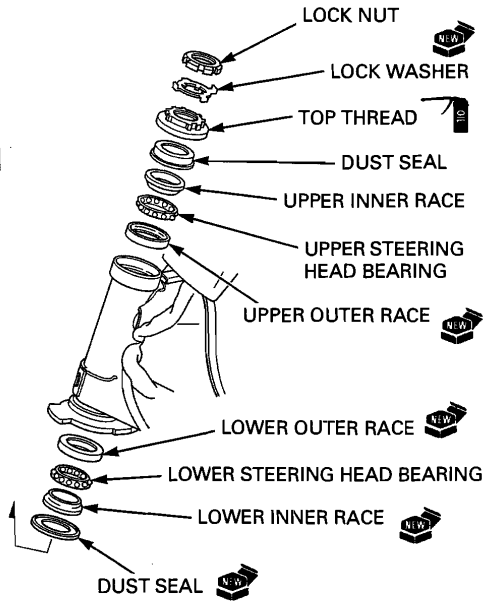
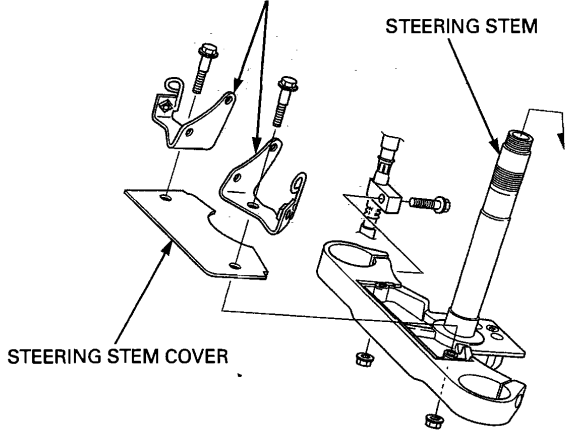

Apply 3 – 5 g of specified grease (page 1-19) to each new steering head bearing and fill it up. Install the lower steering head bearing onto the stem. Apply grease to a new upper dust seal lip. Apply engine oil to the threads of the steering top thread.

Insert the steering stem into the steering head pipe and install the following while holding the stem:

- Upper steering head bearing
- Upper inner race
- Dust seal
- Steering top thread

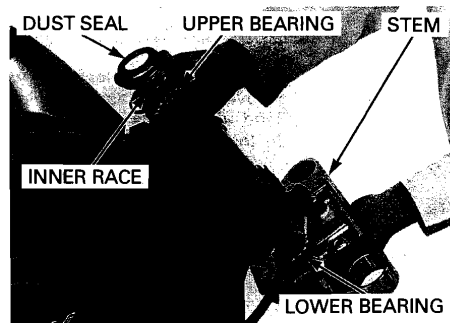

FRONT WHEEL/SUSPENSION/STEERING

Tighten the steering top thread to the specified torque.

TOOL:

Steering stem socket

07916-3710101 or
07916-3710100
(U.S.A. only)

TORQUE: 25 N·m (2.5 kgf·m, 18 lbf·ft)

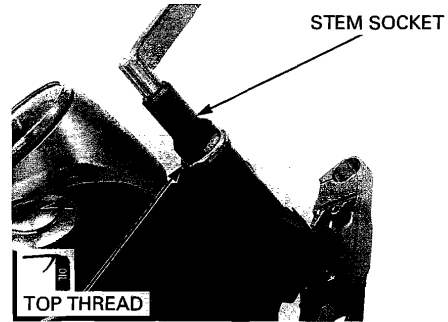

Turn the steering stem left and right, lock-to-lock five times to seat the bearings.

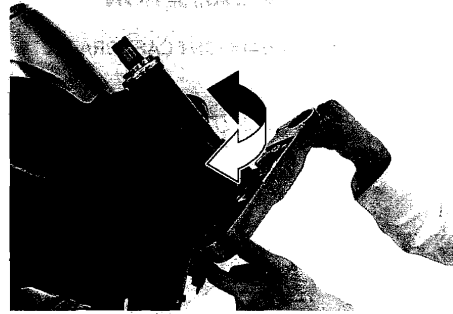

Retighten the steering top thread to the specified torque.

TORQUE: 25 N·m (2.5 kgf·m, 18 lbf·ft)



Install a new lock washer, aligning its bent tabs with the grooves in the steering top thread.

Install the lock nut until it contacts with the lock washer.

Further tighten the lock nut, within 90°, to align its grooves with the tabs of the lock washer. Bend up the lock washer tabs into the grooves of the lock nut.

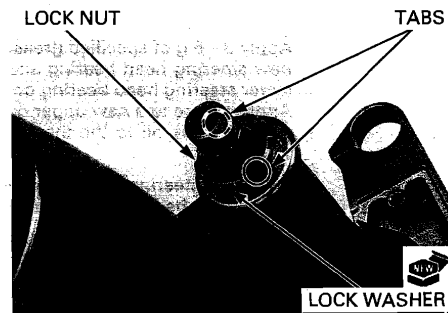

Install the steering stem cover onto the steering stem.

Tighten the nuts securely after installing the headlight case.

Temporarily install the headlight case bracket, bolts and nuts.

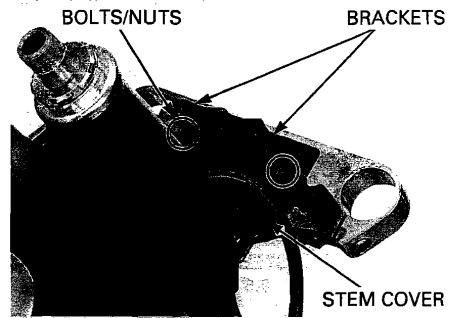

Install the front brake hose, bolt and tighten the bolt securely.

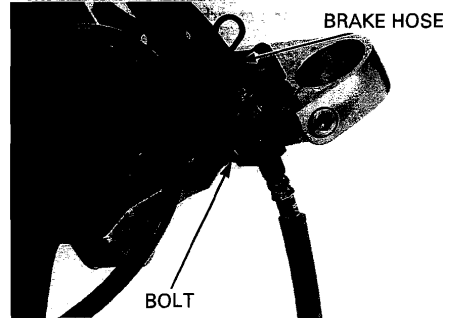

Install the top bridge, washer and stem nut.
Install the fork legs into the steering stem and top bridges (page 15-27).

Tighten the stem nut to the specified torque.

TORQUE: 103 N·m (10.5 kgf·m, 76 lbf·ft)

Turn the steering stem left and right, lock-to-lock several times to make sure the steering stem moves smoothly, without play or binding.

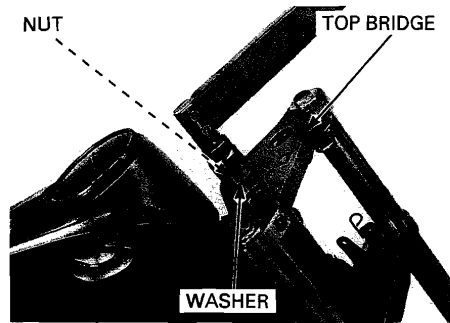

Route the hose, wires and cables into the cable guides properly (page 1-22).

Install the following:

- Front wheel (page 15-18)
- Front fender (page 3-6)
- Handlebar (page 15-9)
- Headlight case (page 21-5)
- Turn signal light (page 21-6)

Tighten the headlight case bracket nuts securely.

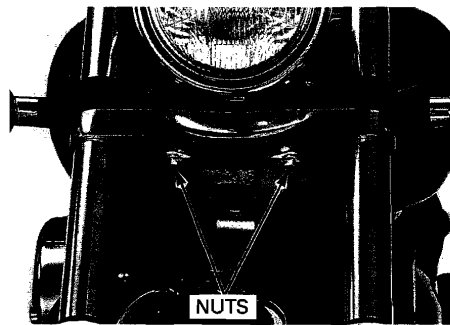

FRONT WHEEL/SUSPENSION/STEERING

STEERING BEARING PRE-LOAD

Support the motorcycle securely and raise the front wheel off the ground.

Position the steering stem straight ahead.

Make sure there is no cable, wire harness or hose interference.

Hook a spring scale to the fork tube between the fork top and bottom bridges.

Pull the spring scale keeping it at a right angle to the steering stem.

Read the scale at the point where the steering stem just starts to move.

STEERING BEARING PRE-LOAD:

8.5 – 12.7 N (0.9 – 1.3 kgf)

If the readings do not fall within the limits, readjust the steering top thread.

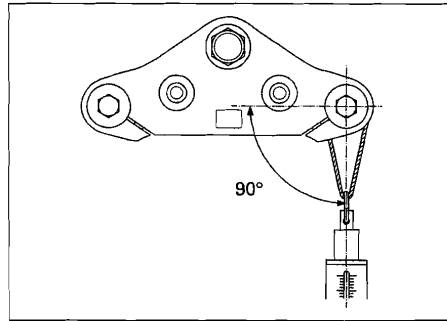

16. REAR WHEEL/BRAKE/SUSPENSION

COMPONENT LOCATION	16-2	REAR BRAKE	16-14
SERVICE INFORMATION	16-3	BRAKE PEDAL	16-17
TROUBLESHOOTING	16-5	SHOCK ABSORBER.....	16-21
REAR WHEEL	16-6	SWINGARM.....	16-22

REAR WHEEL/BRAKE/SUSPENSION COMPONENT LOCATION

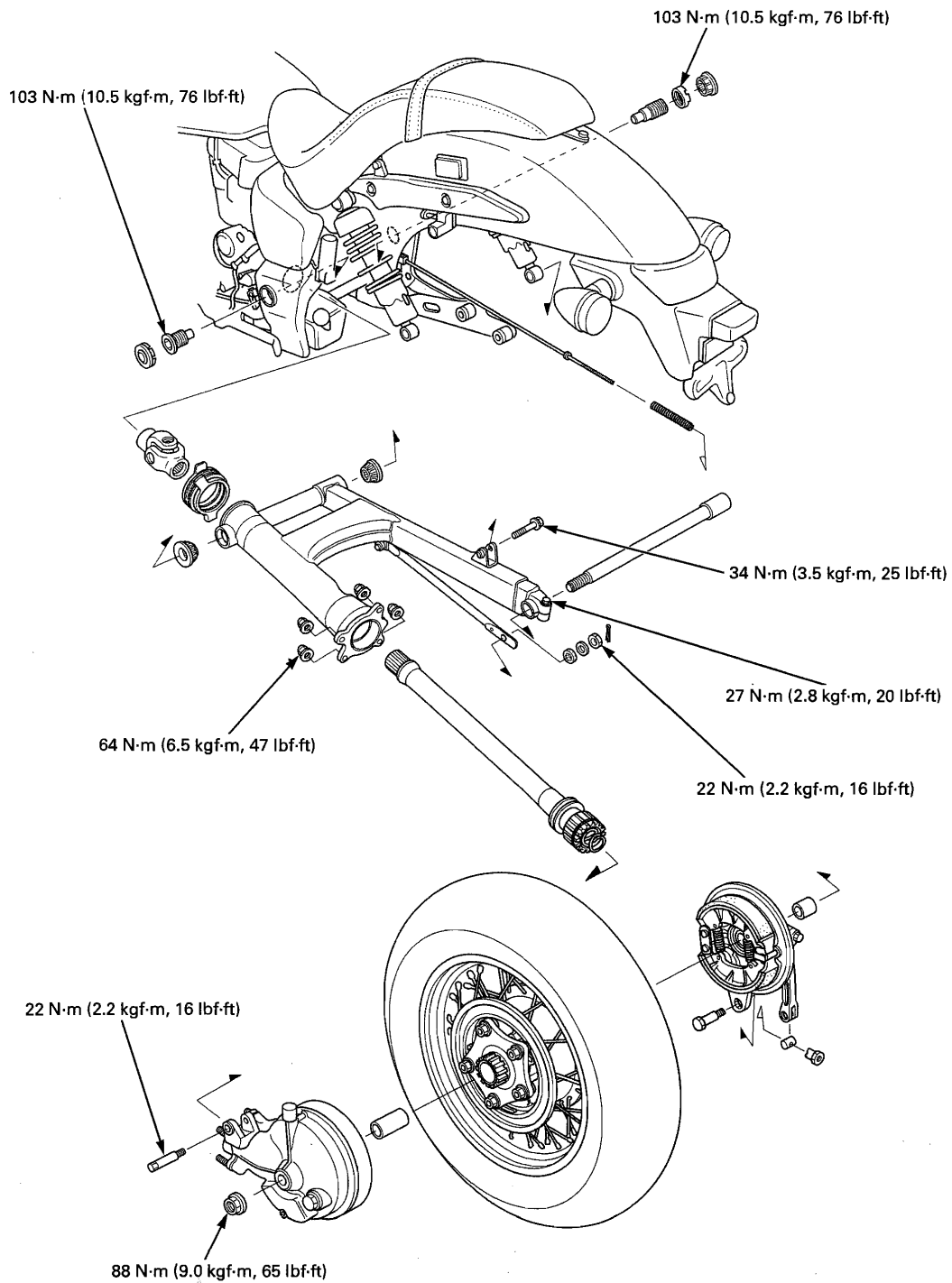

SERVICE INFORMATION

GENERAL

⚠ CAUTION

- Frequent inhalation of brake shoe dust, regardless of material composition could be hazardous to your health.
- Avoid breathing dust particles.
 - Never use an air hose or brush to clean brake assemblies. Use an OSHA-approved vacuum cleaner.

- Riding on damaged rims impairs safe operation of the vehicle.
- A hoist or equivalent is required to support the motorcycle when servicing the rear wheel, shock absorber, or swingarm.
- Use only genuine Honda replacement bolts and nuts for all suspension pivot and mounting points.
- When using the lock nut wrench for the adjusting bolt lock nut, use a deflecting beam type torque wrench 20 inches long. The lock nut wrench increases the torque wrench's leverage, so the torque wrench reading will be less than the torque actually applied to the swingarm right pivot lock nut. The specification given in the actual torque applied to the swingarm right pivot lock nut, not the reading on the torque wrench. Do not overtighten the lock nut. The specification later in the text gives both actual and indicated.

SPECIFICATIONS

ITEM		STANDARD	SERVICE LIMIT
Minimum tire tread depth		-	2.0 (0.08)
Cold tire pressure	Up to 90 kg (200 lbs) load	200 kPa (2.00 kgf/cm ² , 29 psi)	-
	Up to maximum weight capacity	250 kPa (2.50 kgf/cm ² , 36 psi)	-
Axle runout		-	0.2 (0.01)
Wheel rim runout	Radial	-	2.0 (0.08)
	Axial	-	2.0 (0.08)
Wheel balance weight		-	70 g max.
Brake drum I.D.		180.0 – 180.3 (7.09 – 7.10)	181 (7.1)
Brake pedal height		75 mm (3.0 in) above the top of the footpeg	-
Brake pedal freeplay		20 – 30 (13/16 – 1-3/16)	-
Shock absorber spring pre-load adjuster setting		2nd position	-



Unit: mm (in)

TORQUE VALUES

Spoke	4.2 N·m (0.4 kgf·m, 3.1 lbf·ft)	
Rear axle nut	88 N·m (9.0 kgf·m, 65 lbf·ft)	U-nut
Swingarm left pivot bolt	103 N·m (10.5 kgf·m, 76 lbf·ft)	
Swingarm right pivot bolt	See page 16-26	
Swingarm right pivot lock nut	103 N·m (10.5 kgf·m, 76 lbf·ft)	
Stopper plate bolt	20 N·m (2.0 kgf·m, 15 lbf·ft)	ALOC bolt; replace with a new one
Rear axle pinch bolt	27 N·m (2.8 kgf·m, 20 lbf·ft)	
Rear brake stopper arm nut	22 N·m (2.2 kgf·m, 16 lbf·ft)	
Rear brake arm pinch bolt	26 N·m (2.7 kgf·m, 19 lbf·ft)	
Rear shock absorber upper mounting bolt	26 N·m (2.7 kgf·m, 19 lbf·ft)	
Rear shock absorber lower mounting bolt (right side)	34 N·m (3.5 kgf·m, 25 lbf·ft)	
Rear shock absorber lower mounting bolt (left side)	22 N·m (2.2 kgf·m, 16 lbf·ft)	

REAR WHEEL/BRAKE/SUSPENSION

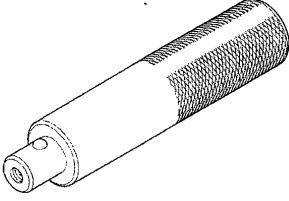
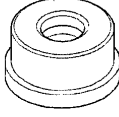
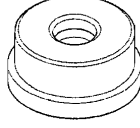
TOOLS

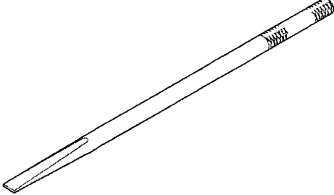
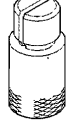
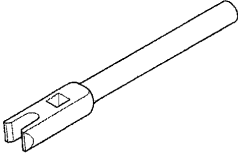
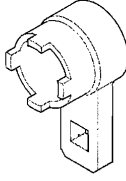
<p>Driver 07749-0010000</p> 	<p>Attachment, 37 x 40 mm 07746-0010200</p> 	<p>Attachment, 42 x 47 mm 07746-0010300</p> 
<p>Pilot, 20 mm 07746-0040500</p> 	<p>Bearing remover shaft 07GGD-0010100</p> 	<p>Bearing remover head, 20 mm 07746-0050600</p> 
<p>Spoke wrench 07JMA-MR60100</p> 	<p>Lock nut wrench 07908-4690003</p> 	

TROUBLESHOOTING**Soft suspension**

- Incorrect suspension adjustment
- Weak shock absorber spring
- Oil leakage from damper unit
- Low tire pressure

Stiff suspension

- Incorrect suspension adjustment
- Bent damper rod
- Damaged shock absorber rubber mounts
- Damaged swingarm pivot bearings
- High tire pressure

Rear suspension noise

- Loose suspension fasteners
- Binding shock absorber case
- Worn shock absorber rubber mounts
- Faulty rear shock absorber

Rear wheel wobbles

- Bent rim
- Unbalanced rear tire and wheel
- Insufficient tire pressure
- Faulty swingarm pivot bearings
- Axle fastener not tightened properly
- Faulty tire

Rear wheel turns hard

- Faulty wheel bearings
- Bent axle
- Brake drag
- Final gear bearings damaged (page 14-7)

Poor brake performance

- Improper brake adjustment
- Worn brake shoes
- Brake linings oily, greasy or dirty
- Worn brake cam
- Worn brake drum
- Brake arm serrations improperly engaged
- Brake shoes worn at cam contact area

REAR WHEEL

REMOVAL

Remove the exhaust system (page 3-8).

Remove the axle nut.

Support the motorcycle securely and raise the rear wheel off the ground.

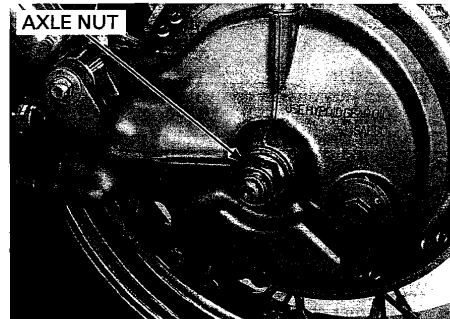

Remove the adjusting nut, joint pin and spring.

Remove the cotter pin, nut, washer, rubber washer and bolt.

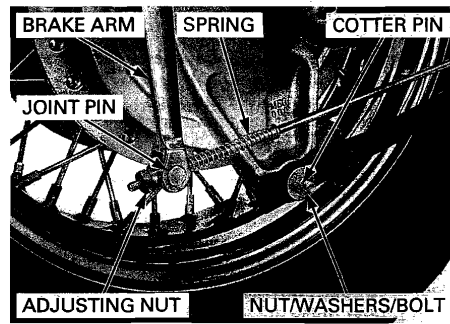

Loosen the pinch bolt and remove the axle and right side collar.

Move the rear wheel to the right to separate it from the final drive gear case and carefully remove the rear wheel out of the frame.

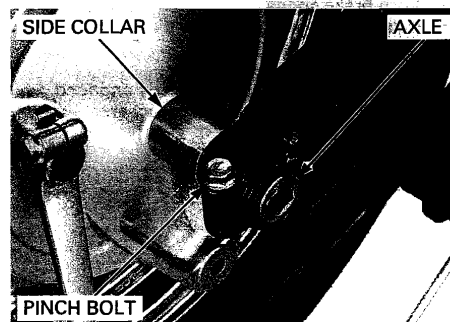

Remove the left side collar from the ring gear.

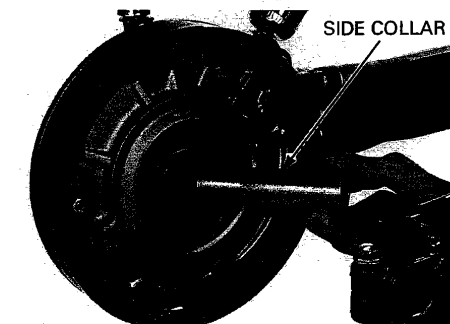

INSPECTION

AXLE

Set the axle in V-blocks.
Turn the axle and measure the runout using a dial indicator.
Actual runout is 1/2 the total indicator reading.

SERVICE LIMIT: 0.2 mm (0.01 in)

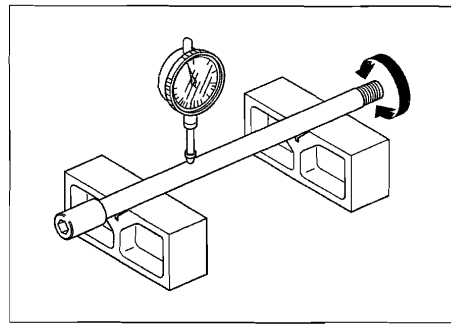

WHEEL RIM

Check the rim runout by placing the wheel in a truing stand.
Spin the wheel slowly and read the runout using a dial indicator.
Actual runout is 1/2 the total indicator reading.

SERVICE LIMITS:

Radial: 2.0 mm (0.08 in)

Axial: 2.0 mm (0.08 in)

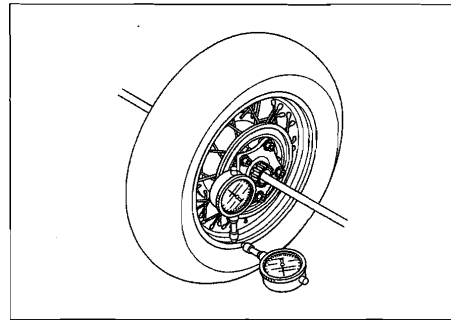

FINAL DRIVEN FLANGE

Check the driven flange splines for wear or damage.
If damaged, check the splines of the ring gear also.

WHEEL BALANCE

For wheel balance (page 15-17). Do not add balance weight more than 70 g to the rear wheel.

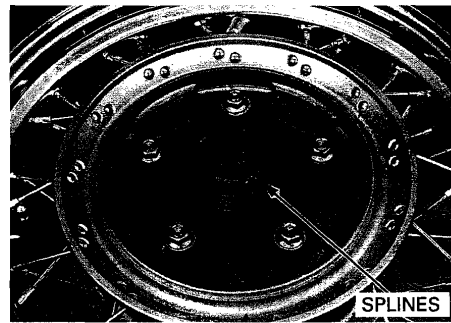

WHEEL BEARING

Remove the brake panel and driven flange (page 16-8).

Turn the inner race of each bearing with your finger. The bearings should turn smoothly and quietly. Also check that the bearing outer race fits tightly in the hub.

Replace the wheel bearings in pairs.

Remove and discard the bearings if the races do not turn smoothly and quietly, or if they fit loosely in the hub.

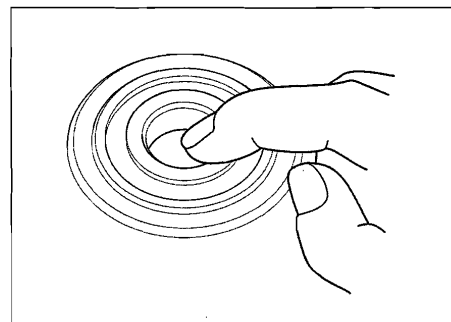

REAR WHEEL/BRAKE/SUSPENSION

DISASSEMBLY

Remove the brake panel assembly from the right wheel hub.

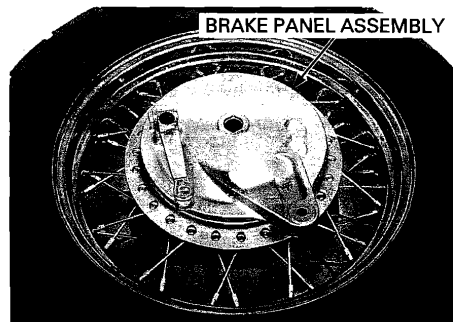

Remove the O-ring.
Remove the final driven flange from the left wheel hub.

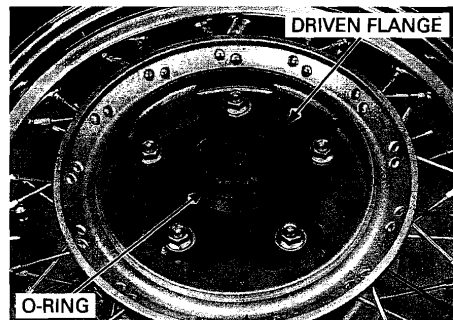

Remove the thrust washer.

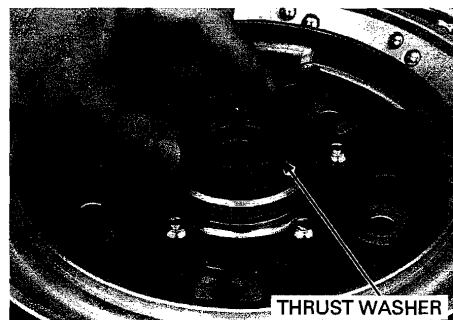

Do not reuse the bolts. Remove the bolts in a crisscross pattern in several steps.
Remove the O-ring.

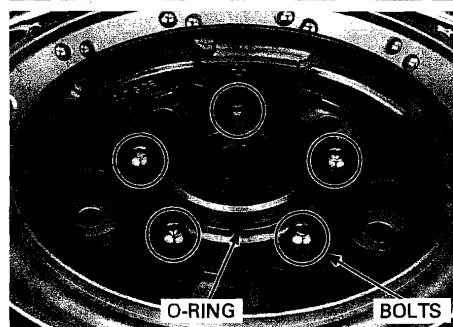

Align the arrow on the stopper plate between the projections on the wheel hub by turning the stopper plate and remove the stopper plate.

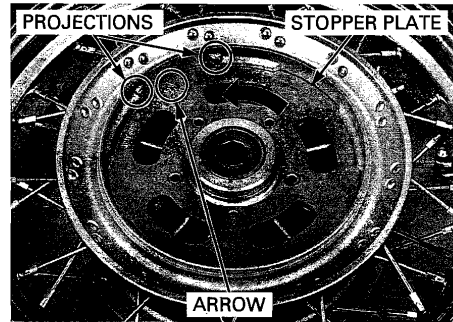

Remove the rubber dampers.

Replace the rubber dampers as a set.

Check the rubber dampers for deterioration or damage.

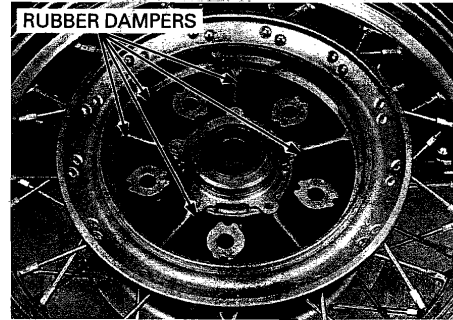

Replace the wheel bearings in pairs. Do not reuse old bearing.

Install the remover head into the bearing. From the opposite side of the wheel, install the remover shaft and drive the bearing out of the wheel hub. Remove the distance collar and drive out the other bearing.

TOOLS:

- Bearing remover shaft 07GGD-0010100
- Bearing remover head, 20 mm 07746-0050600

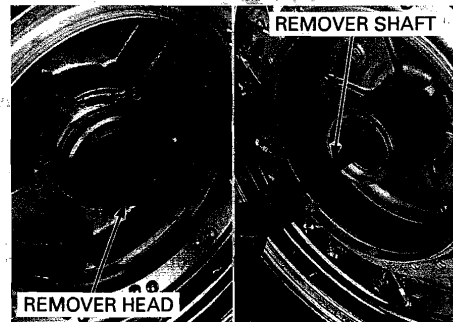

REAR WHEEL/BRAKE/SUSPENSION

ASSEMBLY

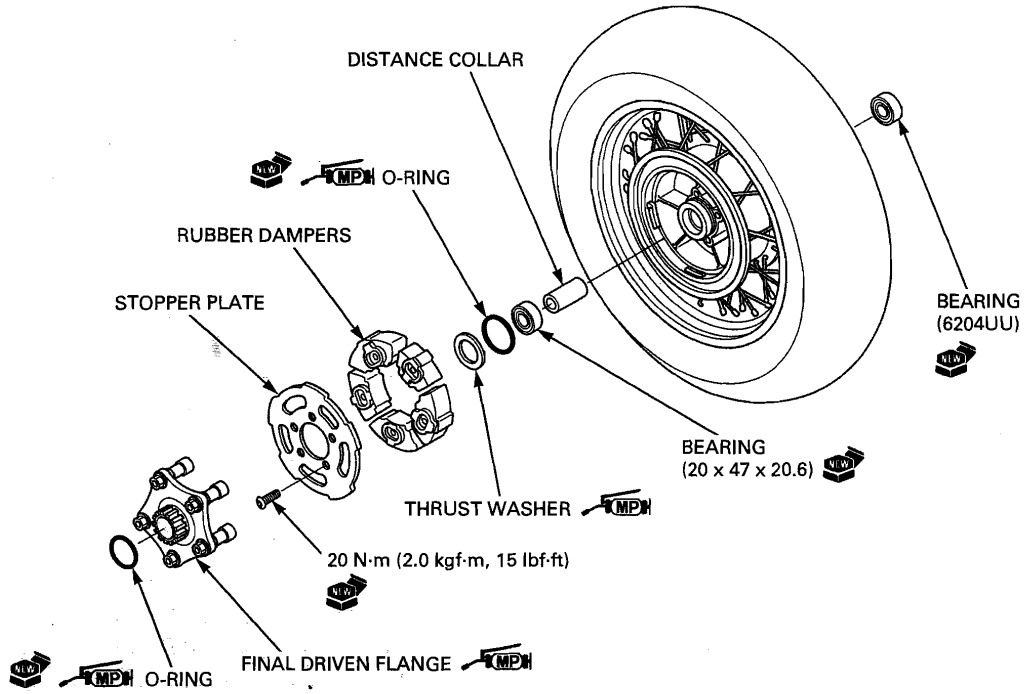

Drive in a new right bearing squarely with the marked side facing up until it is fully seated.

Install the distance collar.

Drive in a new left bearing squarely with the marked side facing up until it is fully seated.

TOOLS:

Driver	07749-0010000
Attachment, 42 x 47 mm	07746-0010300
Pilot, 20 mm	07746-0040500

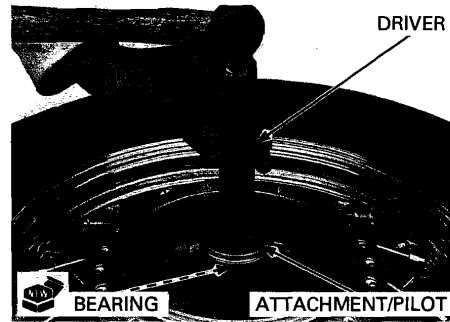

WHEEL CENTER ADJUSTMENT

Measure the distance B (rim width) and calculate distance A as follows:

A = 70.5 mm (2.78 in) – B/2

Adjust the rim position and distance A by tightening the spokes to the specified torque in several progressive steps.

TOOL:

Spoke wrench **07JMA-MR60100**

TORQUE: 4.2 N·m (0.4 kgf·m, 3.1 lbf·ft)

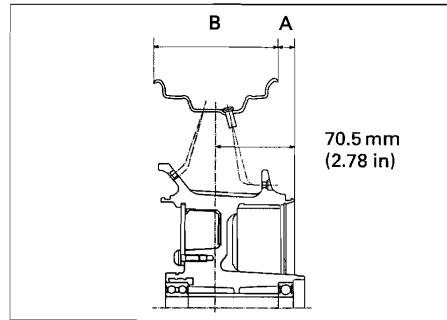

Install the rubber dampers with its "OUT SIDE" mark facing out.

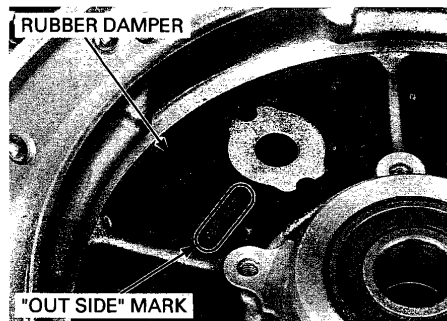

Install the stopper plate with the "OUT SIDE" mark facing up.

Install the stopper plate, aligning the arrow between the projections on the wheel hub. Align the bolt holes by turning the stopper ring.

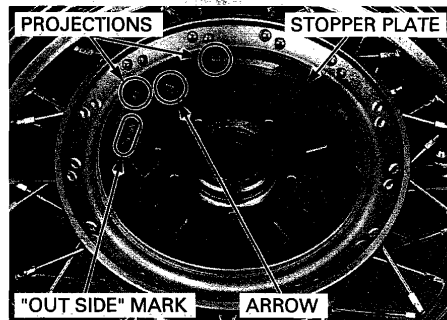

Pack molybdenum disulfide paste into the O-ring groove in the wheel hub. Coat a new O-ring with molybdenum disulfide paste and install it into the left wheel hub groove.

Install and tighten new bolts to the specified torque.

TORQUE: 20 N·m (2.0 kgf·m, 15 lbf·ft)

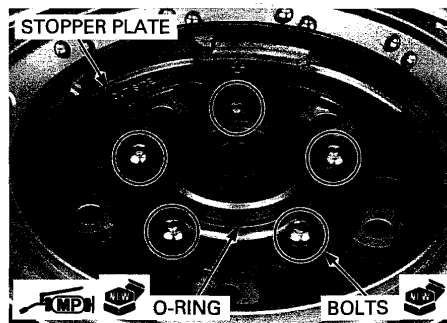

REAR WHEEL/BRAKE/SUSPENSION

Apply 2 – 3 g of molybdenum disulfide paste to the mating surface of the thrust washer and rear wheel hub end (driven flange side).

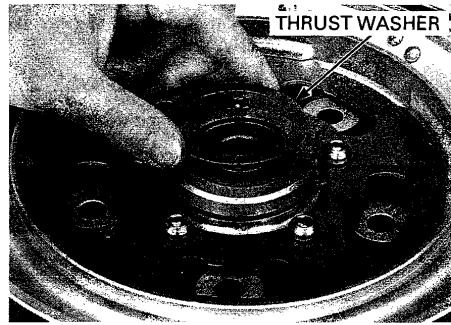

Apply 0.5 – 1.0 g of molybdenum disulfide paste to the rear wheel hub mating surface of the final driven flange.

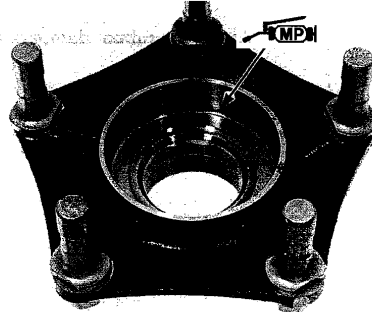

Coat a new O-ring with molybdenum disulfide paste and install it into the driven flange groove.
Install the driven flange into the left wheel hub.

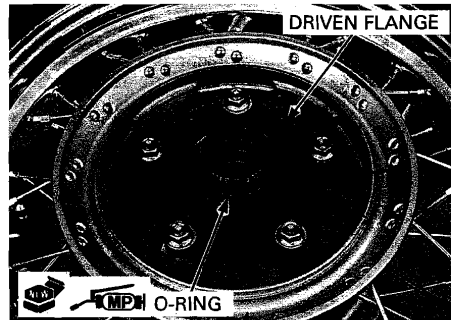

Install the brake panel assembly into the right wheel hub.

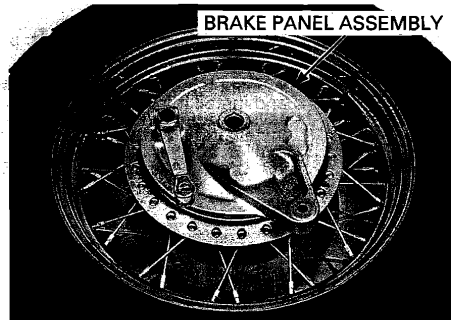

INSTALLATION

Install the left side collar into the ring gear.

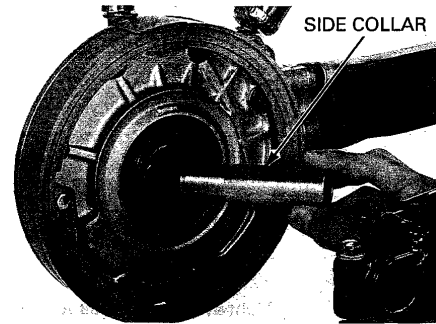

Apply 4 – 5 g of molybdenum disulfide paste to the joint surface of the final gear case O-ring guide and driven flange.

Hold the wheel securely and be careful not to damage the gear case.

Place the rear wheel into the swingarm and engage the driven flange spline with the ring gear spline.

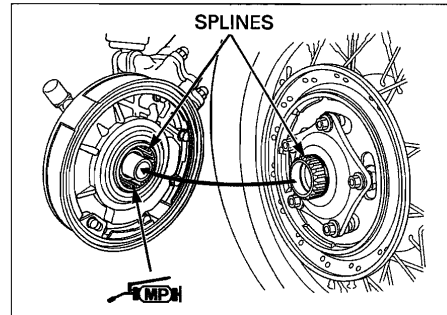

Install the right side collar and rear axle.

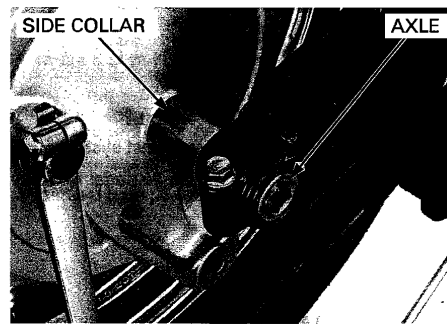

Install and tighten the axle nut to the specified torque while holding the axle.

TORQUE: 88 N-m (9.0 kgf-m, 65 lbf-ft)

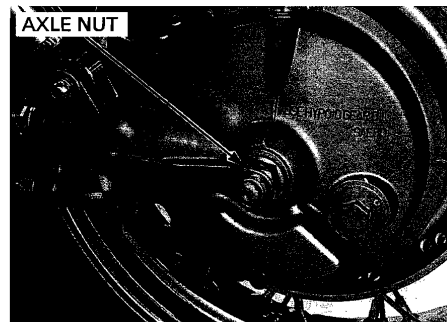

REAR WHEEL/BRAKE/SUSPENSION

With the rear brake applied, pump the swingarm up and down several times to seat the axle.

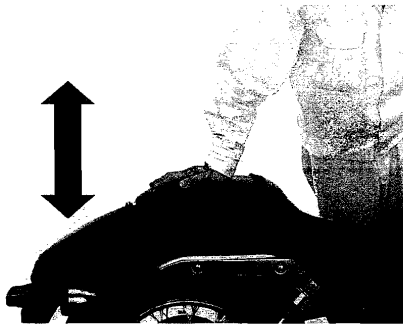

Tighten the pinch bolt to the specified torque.

TORQUE: 27 N·m (2.8 kgf·m, 20 lbf·ft)

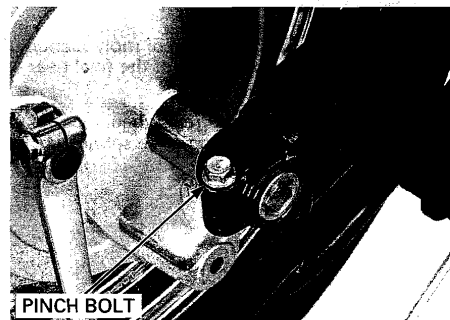

Connect the stopper arm to the brake panel with bolt, rubber washer, washer and nut. Tighten the nut to the specified torque.

TORQUE: 22 N·m (2.2 kgf·m, 16 lbf·ft)

Install a new cotter pin.
Install the spring, joint pin and adjusting nut.
Install the exhaust system (page 3-11).
Adjust the brake pedal freeplay (page 4-21).

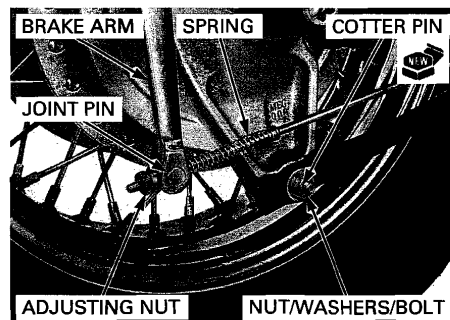

REAR BRAKE

REMOVAL

Remove the rear wheel (page 16-6).
Remove the brake panel from the rear wheel (page 16-8).

INSPECTION

Measure the brake drum I.D.

SERVICE LIMIT: 181 mm (7.1 in)

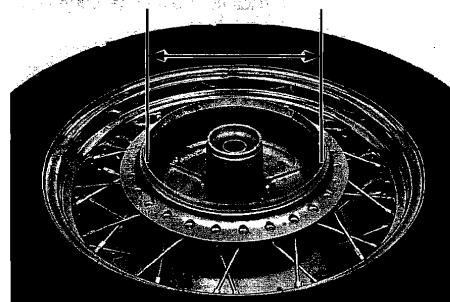

DISASSEMBLY

Remove the cotter pins and setting plate.

NOTE:

- Always replace the brake shoes as a set.
- When the brake shoes are reused, mark all parts before disassembly so they can be installed in their original locations.

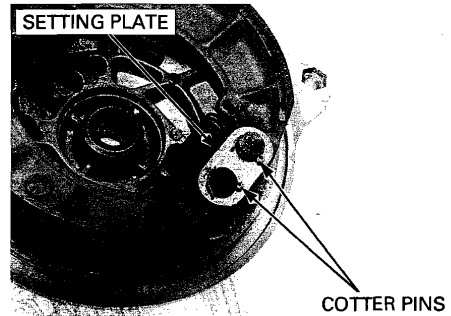

Remove the brake shoes and springs.

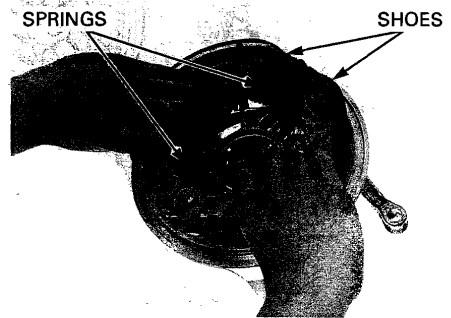

Remove the bolt and brake arm.

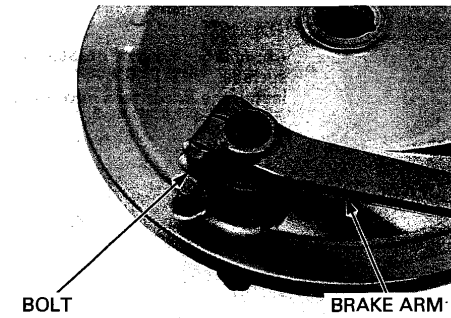

Remove the indicator plate, brake cam and felt seal.

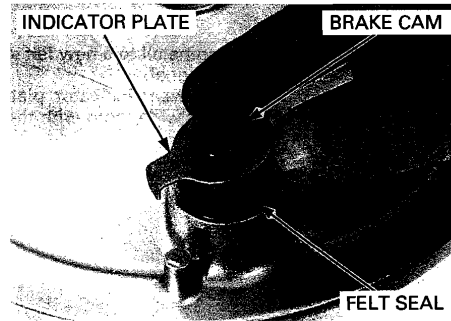

REAR WHEEL/BRAKE/SUSPENSION

ASSEMBLY

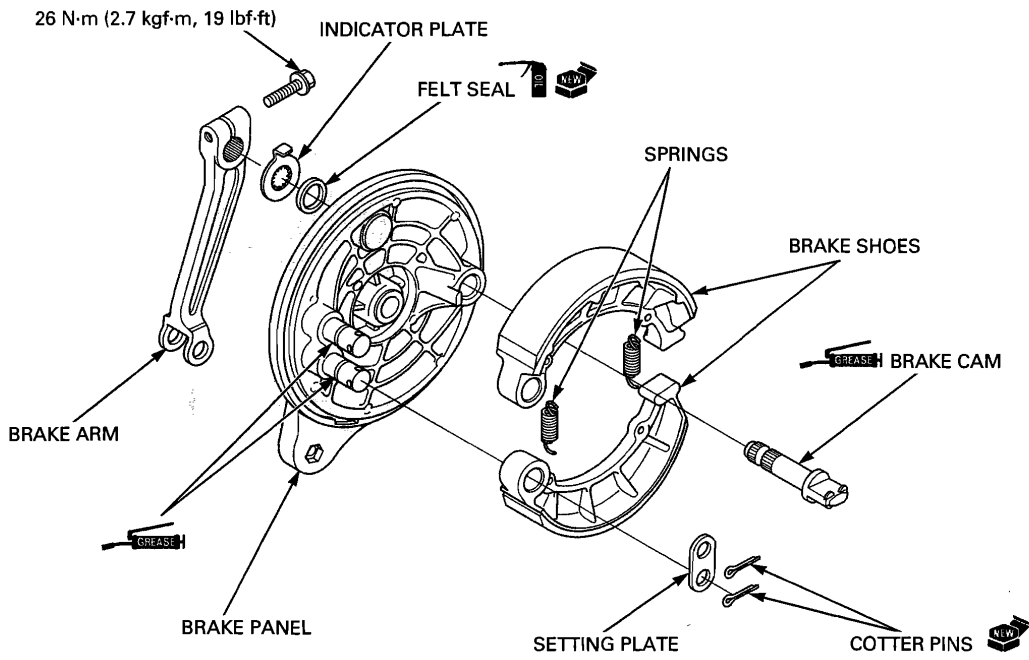

Apply 0.5 – 1.0 g of grease to the brake cam sliding surface.
Install the brake cam into the brake panel.

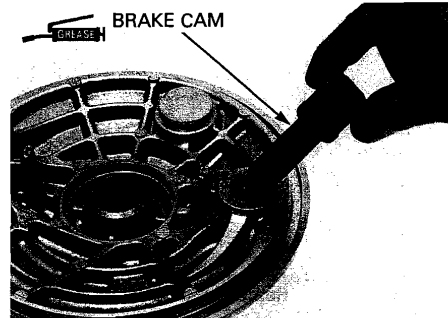

Apply engine oil to a new felt seal and install it onto the brake panel.
Install the wear indicator plate on the brake cam aligning its wide tooth with the wide groove on the brake cam.

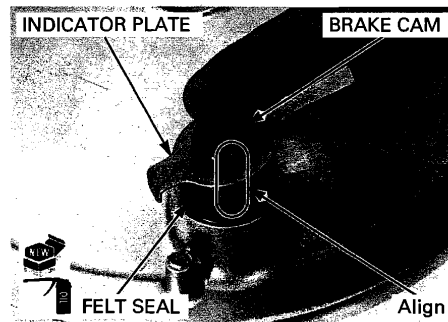

Install the brake arm aligning the punch marks of the arm and the brake cam.
Install and tighten the brake arm pinch bolt to the specified torque.

TORQUE: 26 N·m (2.7 kgf·m, 19 lbf·ft)

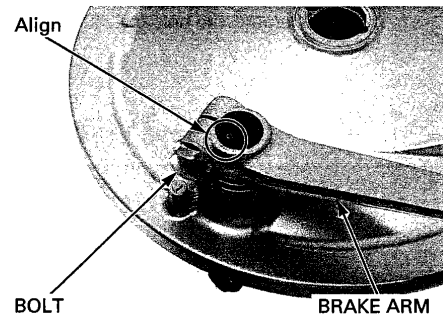

Apply 0.5 – 1.0 g of grease to the brake shoe-to-anchor pin sliding surface.
Install the brake shoes and springs.

NOTE:

- If the brake shoes are reused, the shoes and springs must be placed back in their original locations.
- Install the springs with their ends facing up.

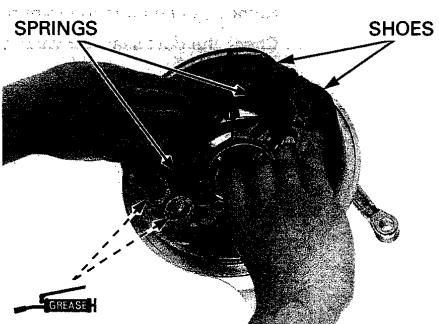

Install the setting plate and new cotter pins as shown.

INSTALLATION

Install the brake panel into the wheel hub (page 16-12).
Install the rear wheel (page 16-13).

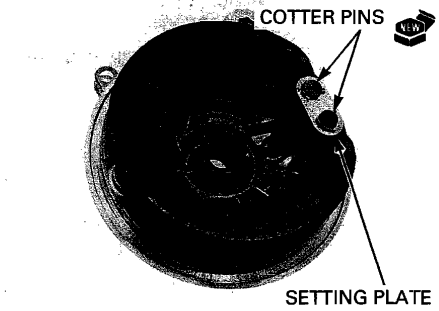

BRAKE PEDAL

REMOVAL

Remove the exhaust system (page 3-8).
Remove the adjusting nut, joint pin and spring.

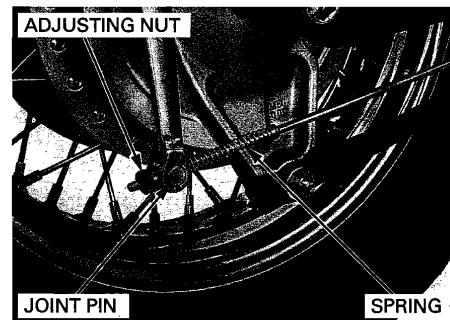

REAR WHEEL/BRAKE/SUSPENSION

Remove the bolt and middle rod joint.

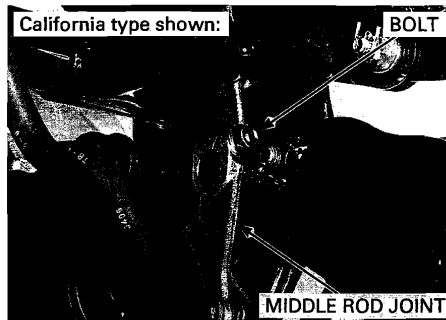

Remove the middle rod joint pivot and dust seals.
Check the dust seals for wear or damage.



Unhook the brake pedal and rear brake light switch return springs.

Remove the snap ring, washer and brake pedal assembly.

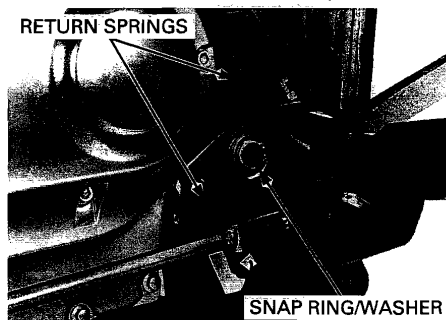

Remove the dust seals.
Check the dust seals for wear or damage.
Remove the cotter pin and joint pin.

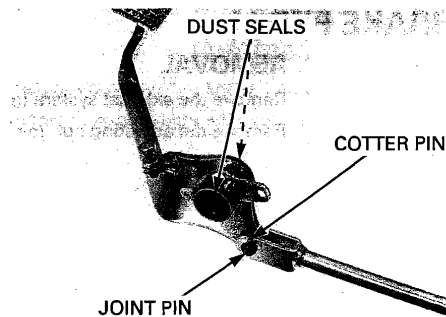

Remove the cotter pins and joint pins.
 Check the brake pedal, rods, middle rod joint and pivot for wear or damage.
 Check the joint pins for wear or damage.
 Replace these parts if necessary.

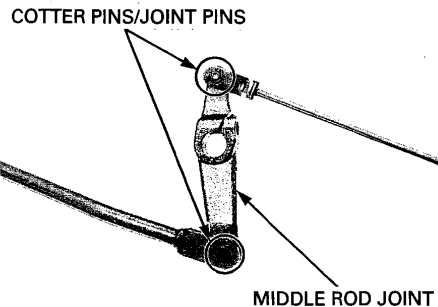

INSTALLATION

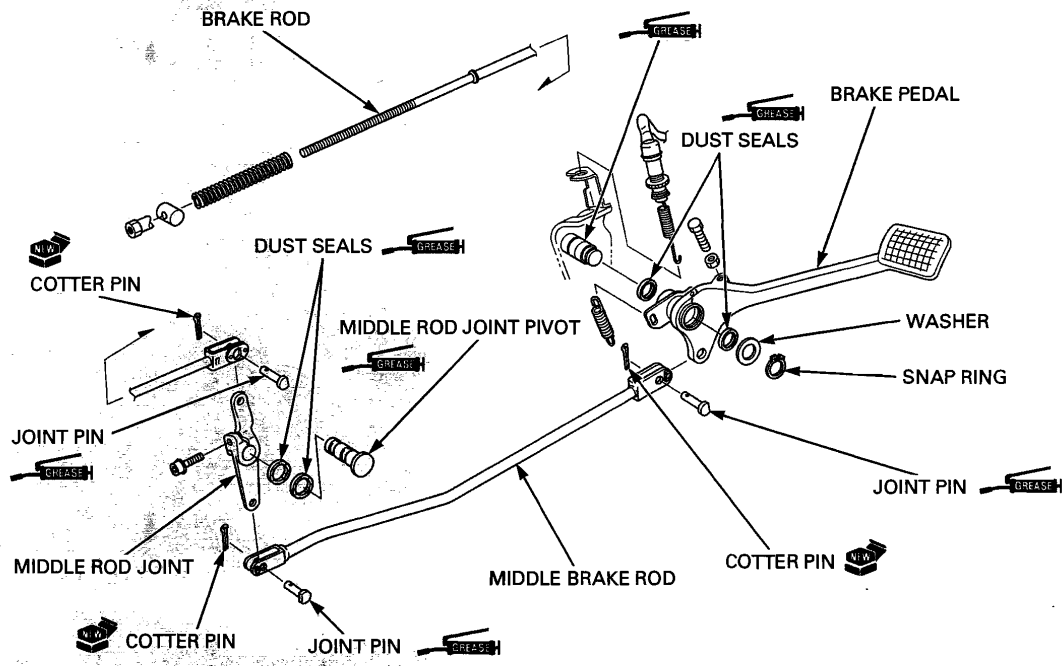

Apply grease to the joint pins.
 Install the brake rods, joint pins and new cotter pins to the middle rod joint.

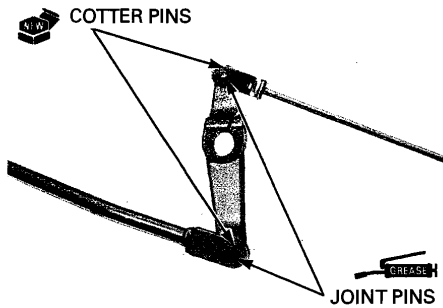

REAR WHEEL/BRAKE/SUSPENSION

Apply grease to the joint pin.
Install the middle brake rod, joint pin and new cotter.
Apply grease to the dust seal lips.
Install the dust seals into the brake pedal.

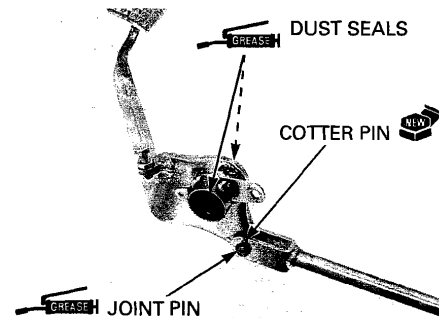

Apply grease to the brake pedal pivot sliding surface.
Install the brake pedal assembly to the bracket properly.
Install the washer and snap ring.

NOTE:

- Install the washers and snap rings with the chamfered edges facing the thrust load side.
- Do not reuse worn snap ring which could easily spin in the groove.
- Check that the snap ring is seated in the grooves.

Hook the brake pedal and rear brake light switch return springs to the pedal.

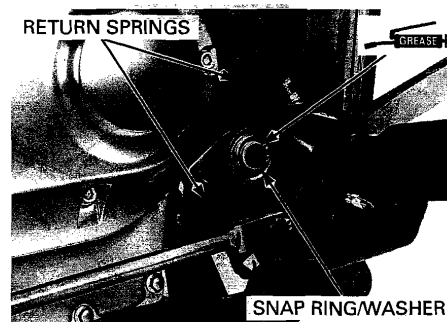

Apply grease to the dust seal lips and middle rod joint pivot sliding surface.
Install the dust seals and middle rod joint pivot.



Install the middle rod joint to the pivot and tighten the bolt securely.

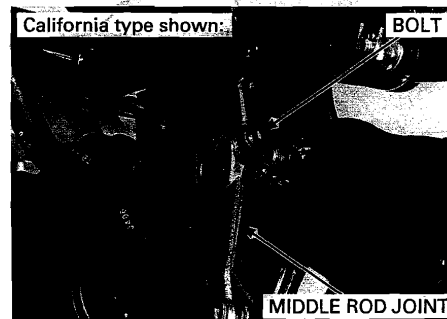

Install the spring, joint pin and adjusting nut.

Install the exhaust system (page 3-11).

Adjust the following:

- Brake pedal freeplay (page 4-21)
- Brake pedal height (page 4-21)
- Rear brake light switch (page 4-22)

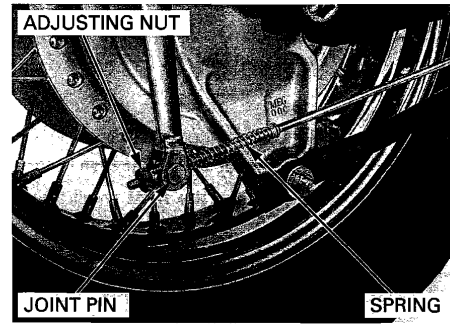

SHOCK ABSORBER

Support the frame and swingarm securely using a hoist or equivalent.

Remove the mounting bolts, washers, and the shock absorber.

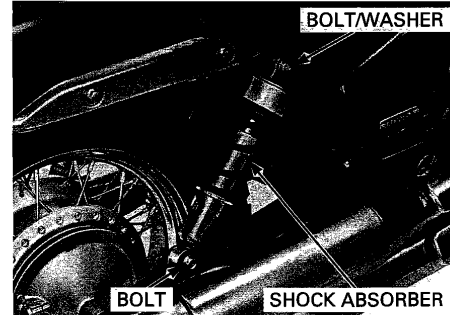

Replace the shock absorber as an assembly.

Check for deformation or oil leakage.

Check the rubber mounts and collars for wear or damage, replace them if necessary.

Apply grease to the shock absorber mount inner surface.

Install the shock absorber in the reverse order of removal.

TORQUE:

Upper mounting bolt:

26 N-m (2.7 kgf-m, 19 lbf-ft)

Lower mounting bolt (right side):

34 N-m (3.5 kgf-m, 25 lbf-ft)

Lower mounting bolt (left side):

22 N-m (2.2 kgf-m, 16 lbf-ft)

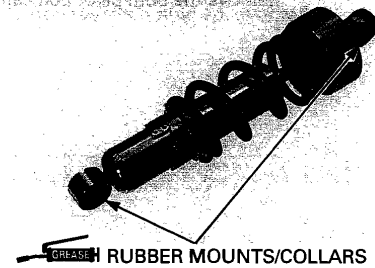

SWINGARM

REMOVAL

Remove the following:

- Left crankcase rear cover (page 3-5)
- Rear wheel (page 16-6)
- Final drive gear case (page 14-7)

Remove the right shock absorber lower mounting bolt.

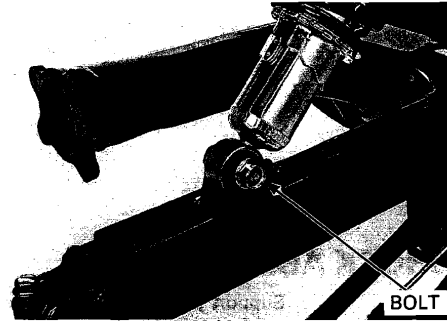

California type only: Disconnect the EVAP canister air vent hose from the EVAP canister.

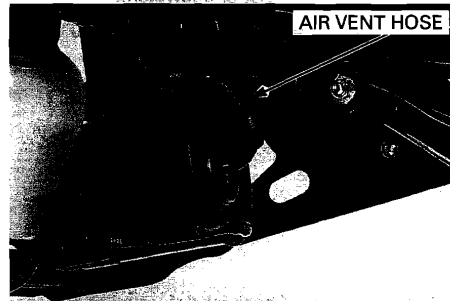

Remove the both pivot bolt caps.

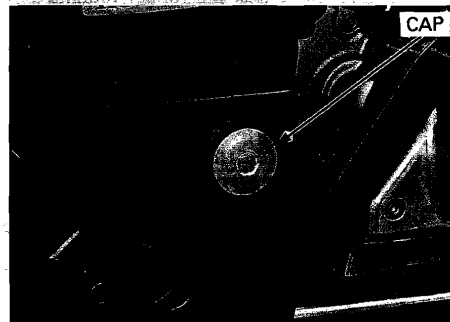

Loosen the right pivot lock nut using a special tool and remove it.

TOOL:

Lock nut wrench **07908-4690003**

Loosen the right pivot bolt, but do not remove it yet.

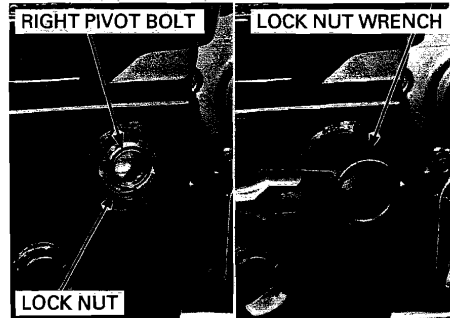

Loosen the left pivot bolt, but do not remove it yet.
 Release the joint boot from the output gear case.
 Remove the left and right pivot bolts, and swingarm
 from the frame.

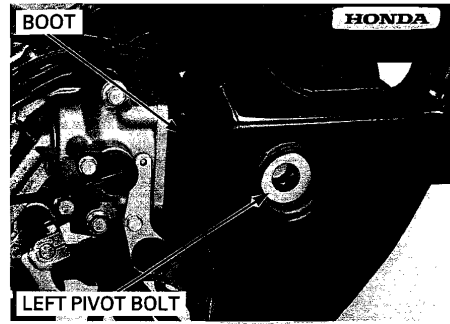

Remove the universal joint from the output shaft.



Remove the following:

- Cotter pin
- Nut
- Washer
- Spring_washer
- Bolt
- Stopper arm

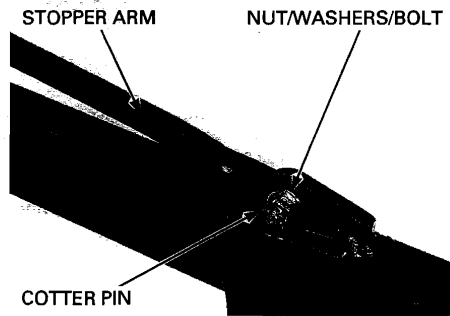

Remove the pivot bearings and joint boot.

INSPECTION

Check the boot for cuts or other damage.

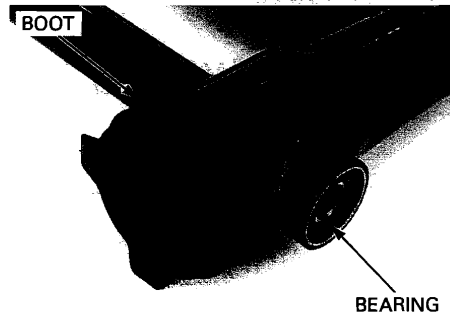

REAR WHEEL/BRAKE/SUSPENSION

Check that the universal joint moves smoothly without binding or noise.
Check the splines for wear or damage.
If damaged, check the splines of the output driven gear shaft and drive shaft also.

SPLINES

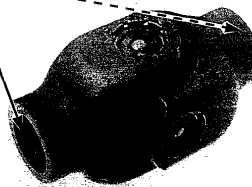

Both bearings, outer races and grease holders must be replaced as a set if any part is damaged or worn.

Check the bearings and dust seals for wear or damage.
Check the outer races for wear or damage.
Check the grease holders for damage or deformation.

GREASE HOLDER

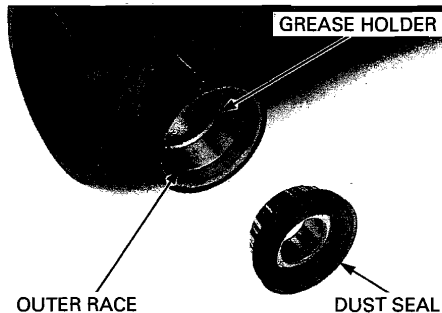

OUTER RACE

DUST SEAL

PIVOT BEARING OUTER RACE REPLACEMENT

Punch or drill an appropriate hole into the grease holder.

Insert a suitable driver through the swingarm and drive the other outer race and grease holder out of the swingarm.

Drive the punched or drilled side outer race and grease holder out of the swingarm.

OUTER RACE

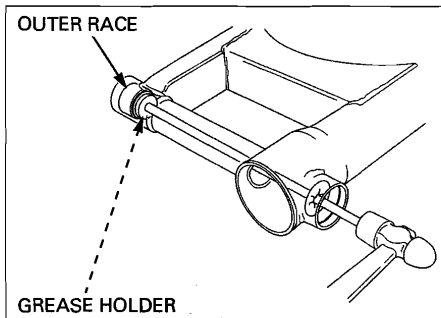

GREASE HOLDER

Install a new grease holder into the pivot.
Drive in a new outer race squarely until it is fully seated.

TOOLS:

Driver
Attachment, 37 x 40 mm

07749-001000
07746-0010200

DRIVER

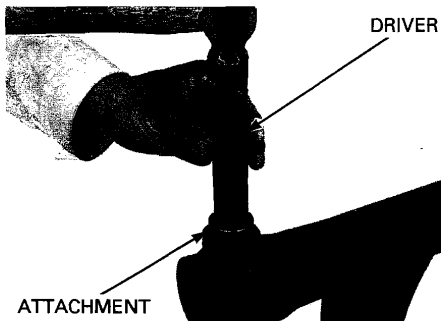

ATTACHMENT

INSTALLATION

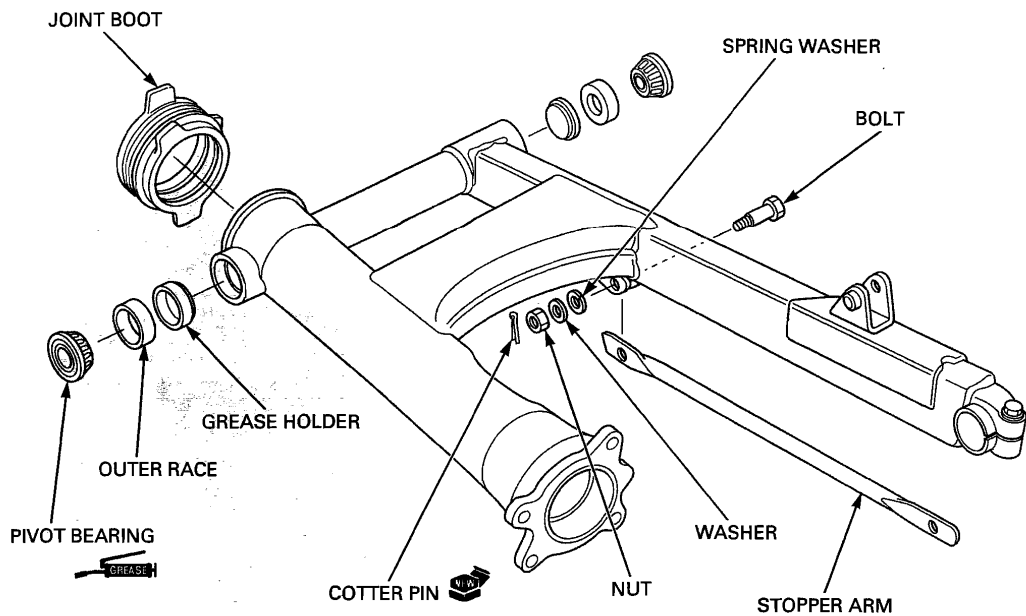

Apply 1.0 – 1.5 g of specified grease (page 1-19) to the needle rollers and dust seal lips of each bearing. Install the pivot bearings into the swingarm pivots.

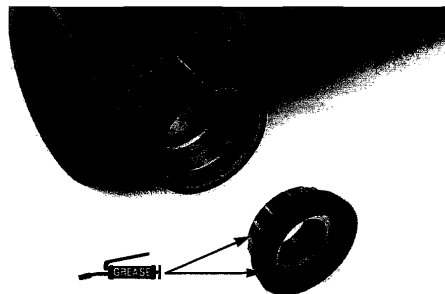

Install the joint boot into the swingarm groove properly with the "UP" mark facing up.

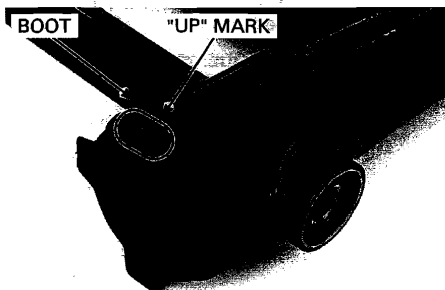

REAR WHEEL/BRAKE/SUSPENSION

Install the following:

- Stopper arm
- Bolt
- Spring washer
- Washer
- Nut

Tighten the nut and install a new cotter pin.

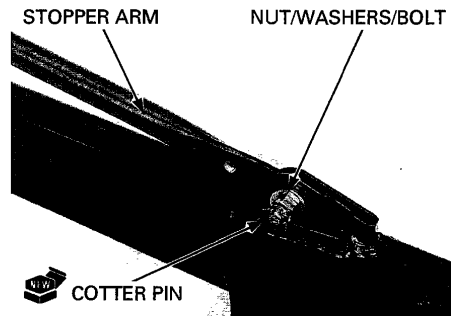

Apply 1 g of molybdenum disulfide grease to the output shaft splines.

Install the universal joint onto the output shaft.



Set the swingarm into the frame and hold it.

Install the joint boot over the output gear case.

Carefully align the swingarm pivots with the pivot bolts.

Install the left and right pivot bolts.

Tighten the left pivot bolt to the specified torque.

TORQUE: 103 N·m (10.5 kgf·m, 76 lbf·ft)

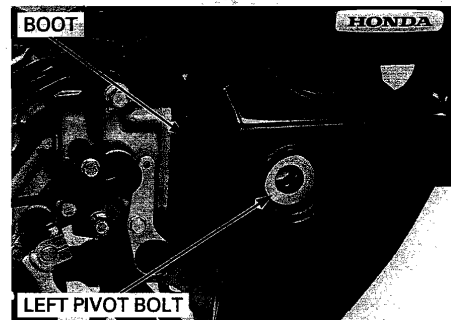

Temporarily tighten the right pivot bolt to the specified torque.

TORQUE: 28 N·m (2.9 kgf·m, 21 lbf·ft)

Move the swingarm up and down several times to seat the pivot bearings.

Loosen the right pivot bolt counterclockwise 1/4 turn (90°) and tighten it to the specified torque.

TORQUE: 22 N·m (2.2 kgf·m, 16 lbf·ft)

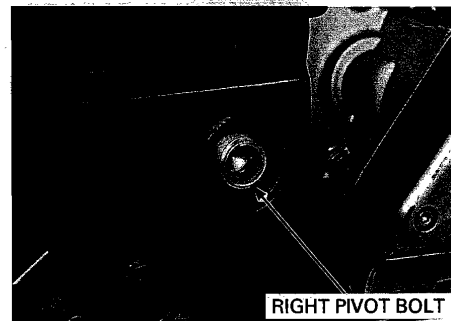

Install the right pivot lock nut.
Tighten the lock nut using the special tool while holding the pivot bolt.

TOOL:
Lock nut wrench 07908-4690003

Refer to torque wrench reading information on page 16-3 "Service Information".

TORQUE:
Actual: 103 N-m (10.5 kgf-m, 76 lbf-ft)
Indicated: 93 N-m (9.5 kgf-m, 69 lbf-ft)

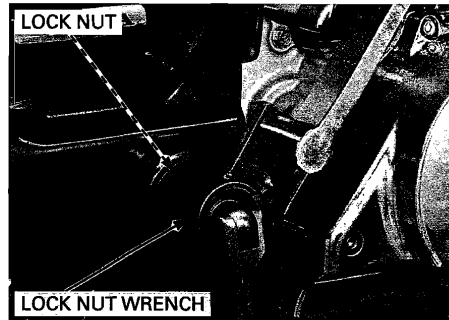

Install the both pivot bolt caps.

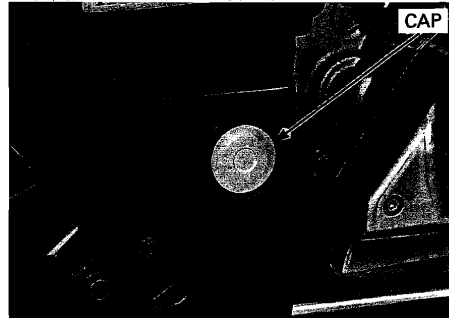

California type only: Connect the EVAP canister air vent hose to the EVAP canister.

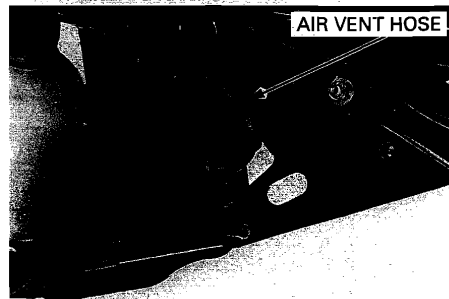

Install and tighten the right shock absorber lower mounting bolt to the specified torque.

TORQUE: 34 N-m (3.5 kgf-m, 25 lbf-ft)

Install the following:

- Final drive gear case (page 14-22)
- Rear wheel (page 16-13)
- Left crankcase rear cover (page 3-5)

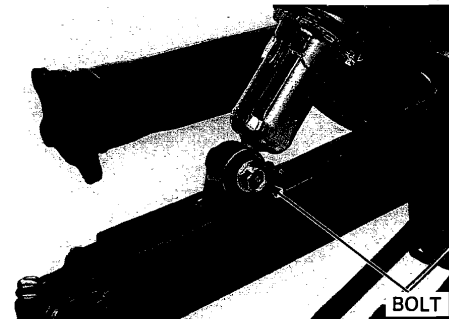

17. HYDRAULIC BRAKE

COMPONENT LOCATION	17-2	BRAKE PAD/DISC	17-7
SERVICE INFORMATION	17-3	MASTER CYLINDER.....	17-8
TROUBLESHOOTING	17-4	FRONT BRAKE CALIPER.....	17-13
BRAKE FLUID REPLACEMENT/ AIR BLEEDING	17-5		

COMPONENT LOCATION

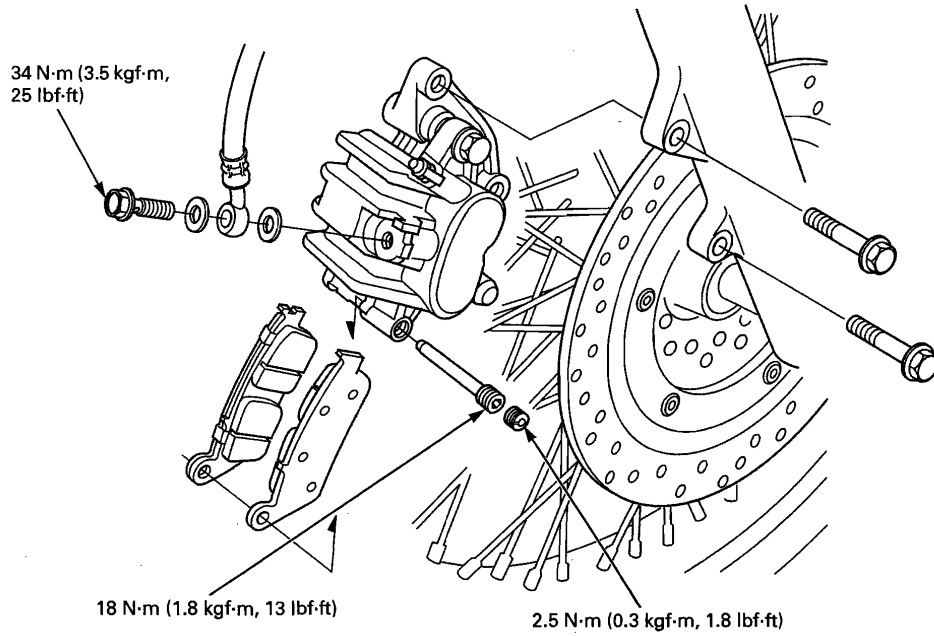
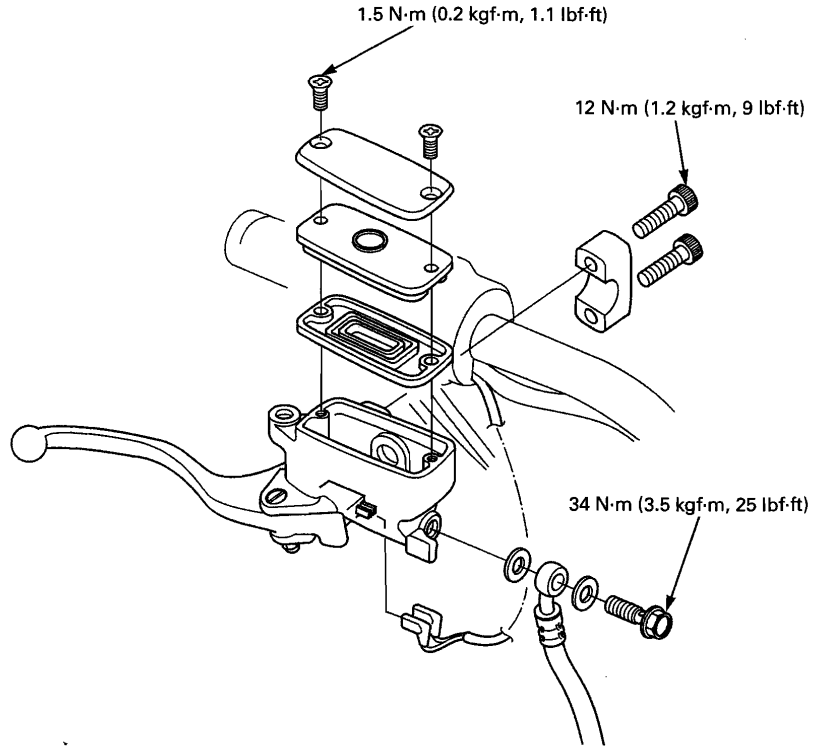

SERVICE INFORMATION**GENERAL****⚠ CAUTION**

Frequent inhalation of brake pad dust, regardless of material composition could be hazardous to your health.

- Avoid breathing dust particles.
- Never use an air hose or brush to clean brake assemblies. Use an OSHA-approved vacuum cleaner.

NOTICE

Spilled brake fluid will severely damage instrument lenses and painted surfaces. It is also harmful to some rubber parts. Be careful whenever you remove the reservoir cap; make sure the front reservoir is horizontal first.

- A contaminated brake disc or pad reduces stopping power. Discard contaminated pads and clean a contaminated disc with a high quality brake degreasing agent.
- Never allow contaminants (e.g., dirt, water) to enter an open reservoir.
- Once the hydraulic system has been opened, or if the brake feels spongy, the system must be bled.
- Always use fresh DOT 4 brake fluid from a sealed container when servicing the system. Do not mix different types of fluid as they may not be compatible.
- Always check brake operation before riding the motorcycle.

SPECIFICATIONS

Unit: mm (in)

ITEM		STANDARD	SERVICE LIMIT
Recommended brake fluid		DOT 4	-
Front	Brake disc thickness	5.8 – 6.2 (0.23 – 0.24)	5.0 (0.20)
	Brake disc warp	-	0.30 (0.012)
	Master cylinder I.D.	11.000 – 11.043 (0.4331 – 0.4348)	11.05 (0.435)
	Master piston O.D.	10.957 – 10.984 (0.4314 – 0.4324)	10.945 (0.4309)
	Caliper cylinder I.D.	27.000 – 27.050 (1.0630 – 1.0650)	27.060 (1.0654)
	Caliper piston O.D.	26.935 – 26.968 (1.0604 – 1.0617)	26.930 (1.0602)

TORQUE VALUES

Brake caliper bleed valve	5.5 N·m (0.6 kgf·m, 4.1 lbf·ft)	
Front master cylinder reservoir cap screw	1.5 N·m (0.2 kgf·m, 1.1 lbf·ft)	
Brake pad pin	18 N·m (1.8 kgf·m, 13 lbf·ft)	
Brake pad pin plug	2.5 N·m (0.3 kgf·m, 1.8 lbf·ft)	
Brake hose oil bolt	34 N·m (3.5 kgf·m, 25 lbf·ft)	
Brake lever pivot bolt	1 N·m (0.1 kgf·m, 0.7 lbf·ft)	
Brake lever pivot nut	6 N·m (0.6 kgf·m, 4.4 lbf·ft)	
Front brake light switch screw	1.2 N·m (0.1 kgf·m, 0.9 lbf·ft)	
Front master cylinder holder bolt	12 N·m (1.2 kgf·m, 9 lbf·ft)	
Front brake caliper bracket pin	12 N·m (1.2 kgf·m, 9 lbf·ft)	Apply locking agent to the threads
Front brake caliper pin	27 N·m (2.8 kgf·m, 20 lbf·ft)	Apply locking agent to the threads
Front brake caliper mounting bolt	30 N·m (3.1 kgf·m, 22 lbf·ft)	ALOC bolt; replace with a new one

TOOL

Snap ring pliers
07914-SA50001

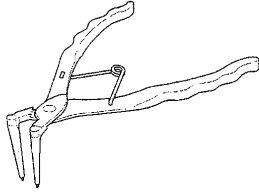

TROUBLESHOOTING

Brake lever soft or spongy

- Air in hydraulic system
- Leaking hydraulic system
- Contaminated brake pads/disc
- Worn caliper piston seals
- Worn master cylinder piston cups
- Worn brake pads/disc
- Contaminated caliper
- Contaminated master cylinder
- Caliper not sliding properly
- Low brake fluid level
- Clogged fluid passage
- Warped/deformed brake disc
- Sticking/worn caliper pistons
- Sticking/worn master piston
- Bent brake lever

Brake lever hard

- Clogged/restricted hydraulic system
- Sticking/worn caliper pistons
- Sticking/worn master piston
- Caliper not sliding properly
- Bent brake lever

Brake drag

- Contaminated brake pads/disc
- Misaligned wheel
- Badly worn brake pads/disc
- Warped/deformed brake disc
- Caliper not sliding properly
- Clogged/restricted fluid passage
- Sticking caliper pistons

BRAKE FLUID REPLACEMENT/AIR BLEEDING

NOTE:

- Do not allow foreign material to enter the system when filling the reservoir.
- When using a commercially available brake bleeder, follow the manufacturer's operating instructions.

BRAKE FLUID DRAINING

Turn the handlebar to the left until the front master cylinder reservoir is level before removing the reservoir cap.

Remove the following:

- Screws
- Reservoir cap
- Set plate
- Diaphragm

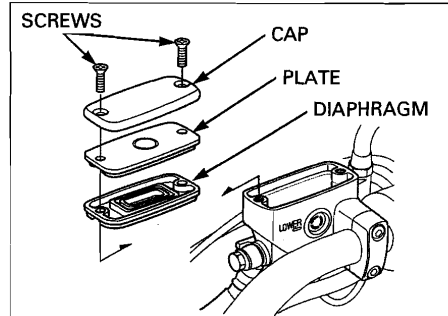

Connect a bleed hose to the bleed valve. Loosen the bleed valve and pump the brake lever until no more fluid flows out of the bleed valve. Tighten the bleed valve.

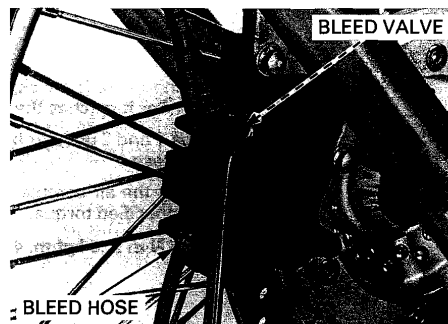

BRAKE FLUID FILLING/BLEEDING

Fill the reservoir with DOT 4 brake fluid from a sealed container.

Connect a commercially available brake bleeder to the bleed valve.

Operate the brake bleeder and loosen the bleed valve.

If an automatic refill system is not used, add brake fluid when the fluid level in the reservoir is low.

NOTE:

- Check the fluid level often while bleeding to prevent air from being pumped into the system.
- When using a brake bleeding tool, follow the manufacturer's operating instructions.

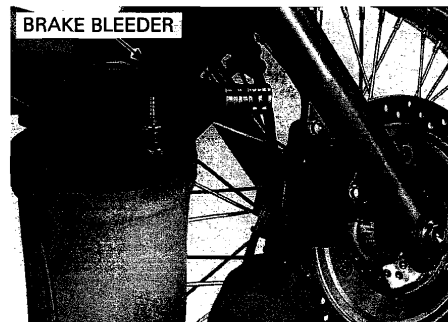

HYDRAULIC BRAKE

Perform the bleeding procedure until the system is completely flushed/bled.

NOTE:

- If air is entering the bleeder from around the bleed valve threads, seal the threads with teflon tape.

Close the bleed valve and operate the brake lever. If it is still spongy, bleed the system again.

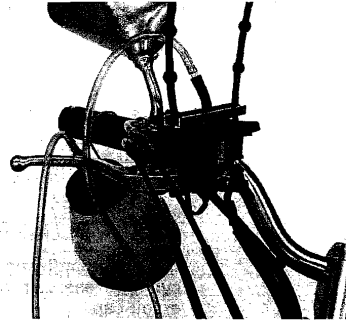

If a brake bleeder is not available, use the following procedure:

Fill the reservoir with DOT 4 brake fluid from a sealed container.

Connect a bleed hose to the bleed valve.

Pressurize the system with the brake lever until lever resistance is felt.

Do not release the lever until the bleed valve has been closed.

1. Squeeze the brake lever, open the bleed valve 1/4 turn and then close it.

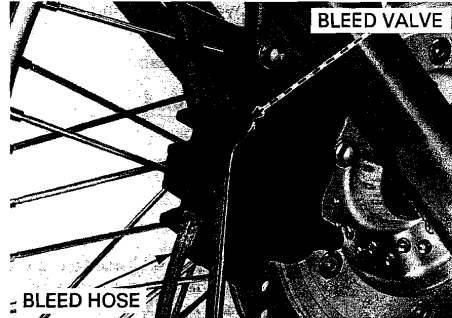

2. Release the brake lever slowly and wait several seconds after it reaches the end of its travel.

Repeat steps 1 and 2 until air bubbles do not appear in the bleed hose.

After bleeding the air completely, tighten the bleed valve to the specified torque.

TORQUE: 5.5 N-m (0.6 kgf-m, 4.1 lbf-ft)

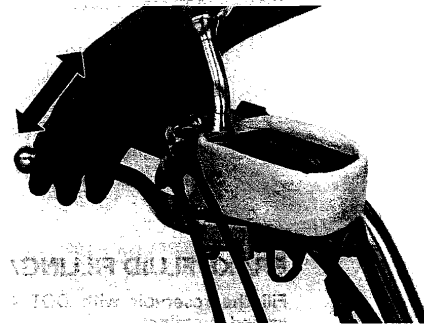

Fill the reservoir to the casting ledge with DOT 4 brake fluid.

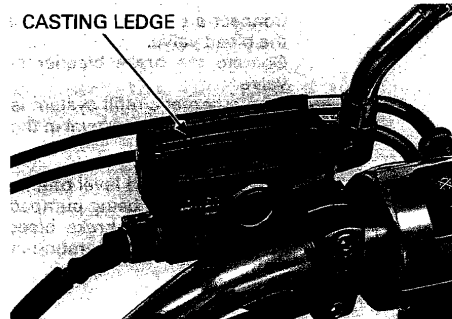

Install the following:

- Diaphragm
- Set plate
- Reservoir cap
- Screws

Tighten the screws to the specified torque.

TORQUE: 1.5 N-m (0.2 kgf-m, 1.1 lbf-ft)

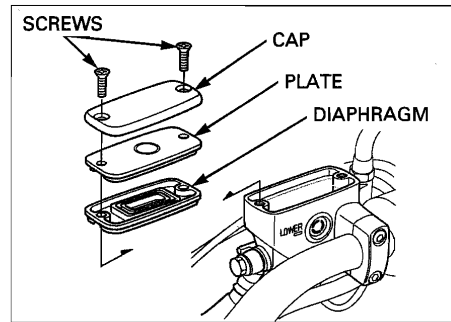

BRAKE PAD/DISC

BRAKE PAD REPLACEMENT

Check the brake fluid level in the reservoir as this operation causes the level to rise.

Push the caliper piston all the way in to allow installation of new brake pads.

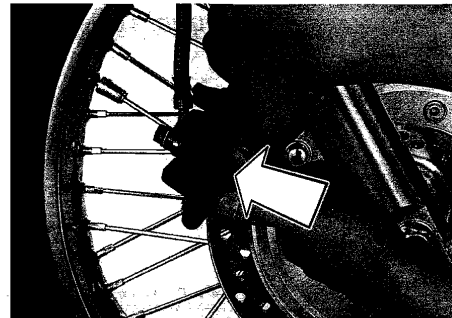

Remove the pad pin plug and loosen the pad pin.

Pull the pad pin out of the caliper body while pushing in the pads against the pad spring.

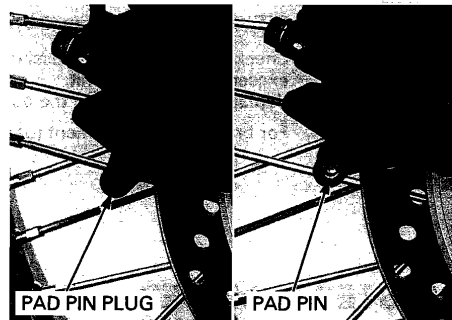

Remove the brake pads.

Make sure the pad spring is installed correctly. Always replace the brake pads in pairs to ensure even disc pressure.

Install new brake pads into the caliper so their ends rest into the pad retainer on the bracket properly.

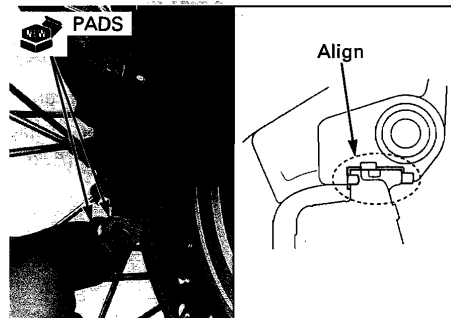

HYDRAULIC BRAKE

Install the pad pin by pushing in the pads against the pad spring to align the pad pin holes in the pads with the caliper body.

Tighten the pad pin to the specified torque.

TORQUE: 18 N·m (1.8 kgf·m, 13 lbf·ft)

Install the pad pin plug and tighten it to the specified torque.

TORQUE: 2.5 N·m (0.3 kgf·m, 1.8 lbf·ft)

Operate the brake lever to seat the caliper piston against the pads.

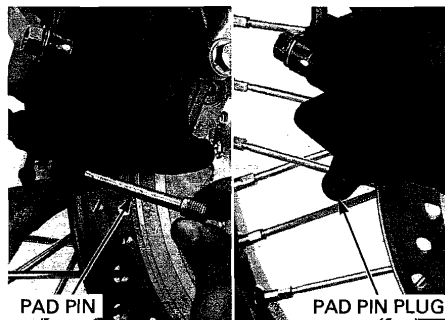

BRAKE DISC INSPECTION

Visually inspect the disc for damage or cracks.

Measure the brake disc thickness at several points.

SERVICE LIMIT: 5.0 mm (0.20 in)

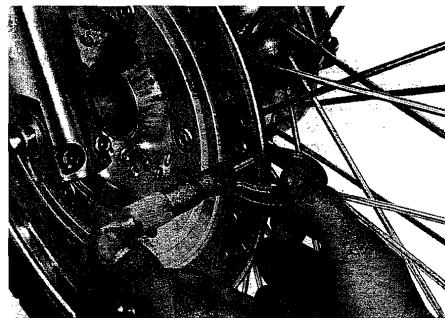

Measure the brake disc warpage with a dial indicator.

SERVICE LIMIT: 0.30 mm (0.012 in)

Check the bearing for excessive play, if the warpage exceeds the service limit.

Replace the brake disc if the bearings are normal.

For brake disc replacement (page 15-15).

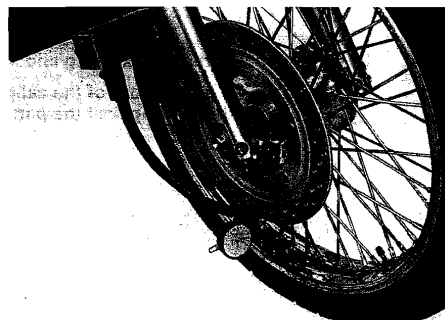

MASTER CYLINDER

DISASSEMBLY

Drain the brake fluid from the hydraulic system (page 17-5).

Remove the rearview mirror.

Remove the oil bolt and sealing washers.

Disconnect the front brake light switch connectors.

When removing the oil bolt, cover the end of the hose to prevent contamination.

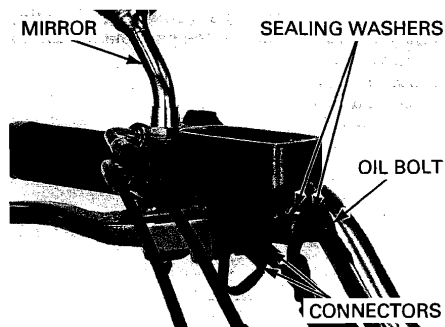

Remove the bolts, holder and master cylinder.

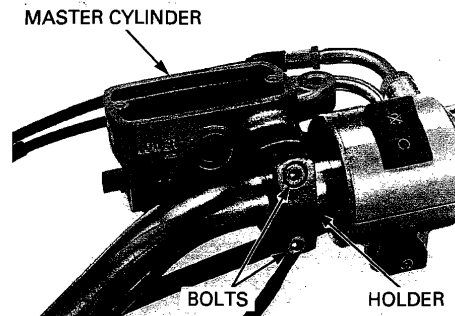

Remove the nut, pivot bolt and brake lever.

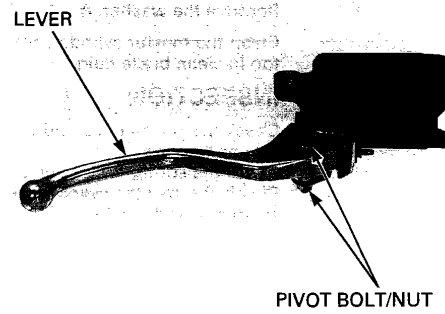

Remove the screw and front brake light switch.

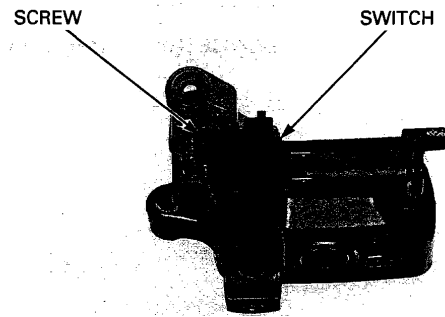

Remove the boot.

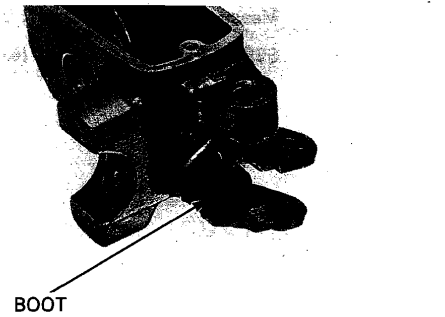

HYDRAULIC BRAKE

Remove the snap ring using a special tool.

TOOL:

Snap ring pliers

07914-SA50001

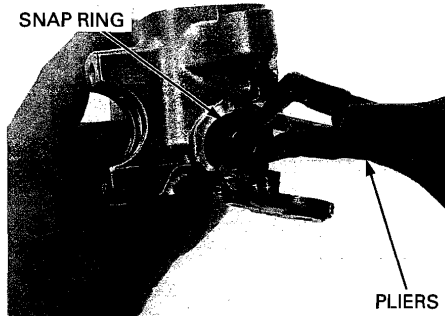

Remove the washer, master piston and spring.

Clean the master cylinder, reservoir and master piston in clean brake fluid.

INSPECTION

Check the piston cups and boot for wear, deterioration or damage.

Check the spring for fatigue or damage.

Check the master cylinder and piston for scoring, scratches or damage.

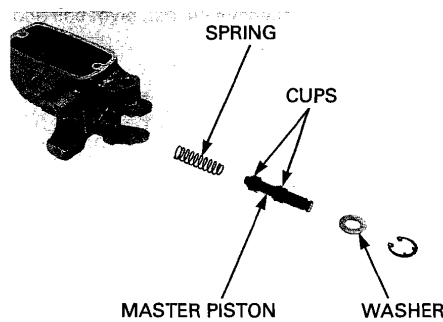

Measure the master cylinder I.D.

SERVICE LIMIT: 11.05 mm (0.435 in)

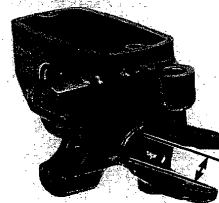

Measure the master piston O.D.

SERVICE LIMIT: 10.945 mm (0.4309 in)



ASSEMBLY

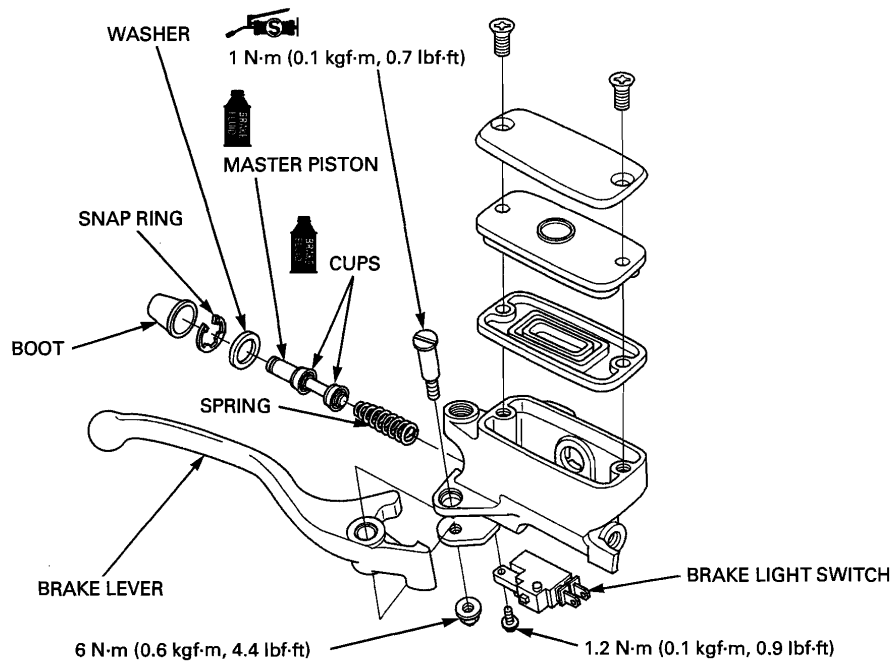

NOTE:
 Replace the piston, spring, cups, washer and snap ring as a set.

Coat the master piston and piston cups with clean brake fluid.
 Install the spring onto the piston end.

Do not allow the piston cup lips to turn inside out.

Install the master piston/spring into the master cylinder.
 Install the washer on the piston.

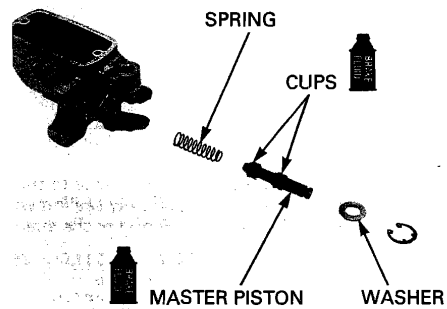

Install the snap ring into the groove in the master cylinder using a special tool.

TOOL:
Snap ring pliers 07914-SA50001

- Install the snap ring and washer with the chamfered edges facing the thrust load side.
- Do not reuse worn snap ring which could easily spin in the groove.
- Check that the snap ring is seated in the grooves.

Install the boot into the master cylinder and piston groove.

Apply 0.1 g of silicone grease to the brake lever contacting area of the piston.

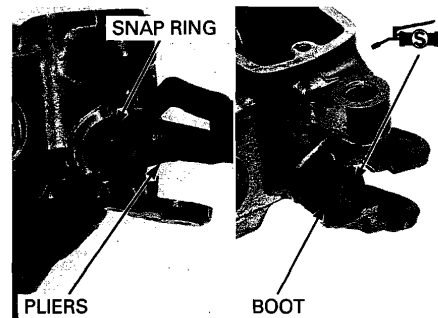

HYDRAULIC BRAKE

Install the brake light switch, aligning its boss with the groove of the master cylinder.

Install and tighten the screw to the specified torque.

TORQUE: 1.2 N-m (0.1 kgf-m, 0.9 lbf-ft)

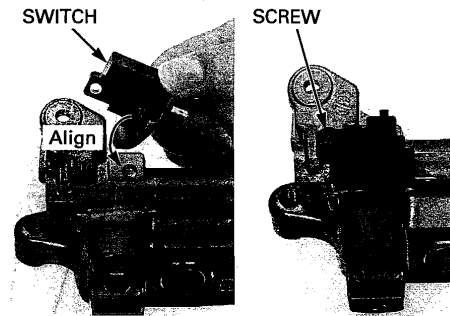

Apply 0.1 g of silicone grease to the brake lever pivot sliding surface.
Install the brake lever and pivot bolt, and tighten it to the specified torque.

TORQUE: 1 N-m (0.1 kgf-m, 0.7 lbf-ft)

Tighten the nut to the specified torque while holding the pivot bolt.

TORQUE: 6 N-m (0.6 kgf-m, 4.4 lbf-ft)

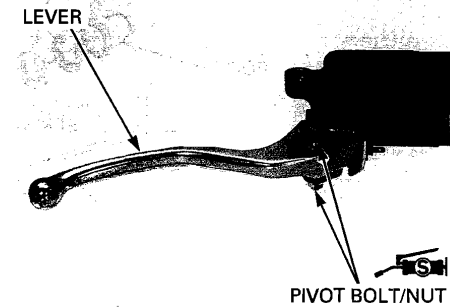

Install the holder with its "UP" mark facing up.

Install the master cylinder with the holder and two bolts.

Align the edge of the master cylinder with the punch mark on the handlebar and tighten the upper bolt first, then tighten the lower bolt to the specified torque.

TORQUE: 12 N-m (1.2 kgf-m, 9 lbf-ft)

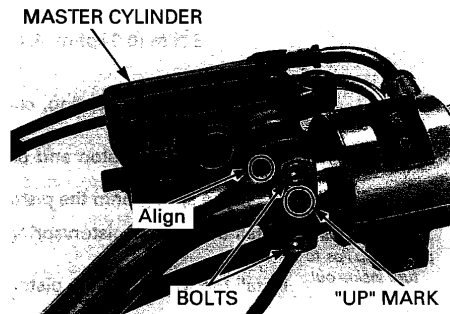

Be sure to rest the hose joint against the stopper.

Connect the brake hose to the master cylinder with the oil bolt and new sealing washers. Tighten the oil bolt to the specified torque.

TORQUE: 34 N-m (3.5 kgf-m, 25 lbf-ft)

Install the rearview mirror.

Connect the brake light switch connectors.

Fill and bleed the hydraulic system (page 17-5).

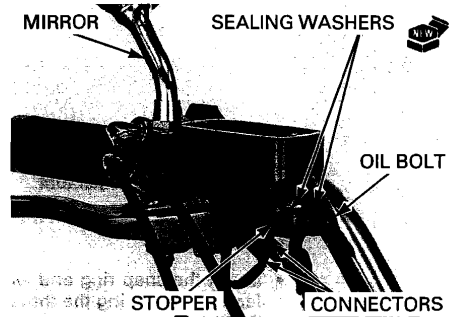

FRONT BRAKE CALIPER

DISASSEMBLY

Drain the brake fluid from the hydraulic system (page 17-5).

Remove the brake pads (page 17-7).

Remove the oil bolt and sealing washers.

When removing the oil bolt, cover the end of hose to prevent contamination.

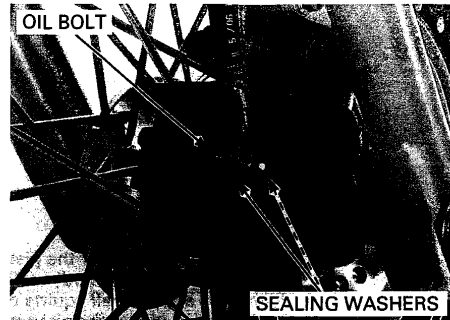

Do not reuse the caliper mounting bolts. Remove the mounting bolts and brake caliper assembly.

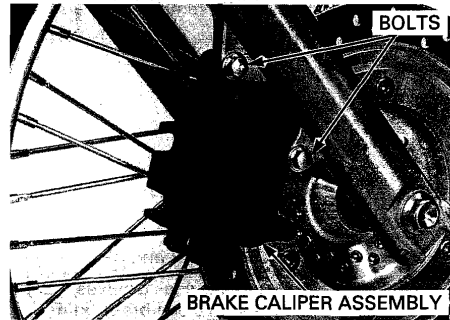

Remove the bracket from the caliper body.

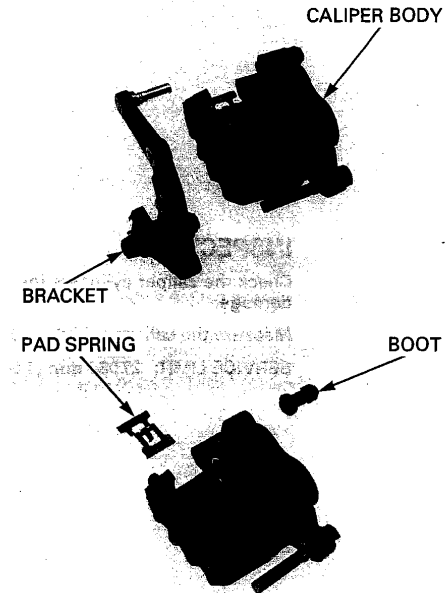

Remove the bracket pin boot and pad spring from the caliper body.

HYDRAULIC BRAKE

Remove the caliper pin boot and pad retainer from the bracket.
Clean the retainer and bracket mating surfaces.

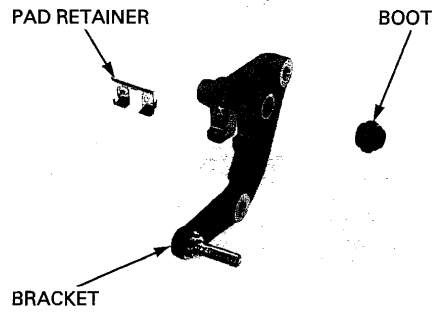

Do not use high pressure air or bring the nozzle too close the inlet.

Place a shop towel over the pistons.
Position the caliper body with the piston facing down and apply small squirts of air pressure to the fluid inlet to remove the pistons.



Be careful not to damage the piston sliding surface.

Push the dust and piston seals in and lift them out.
Clean the seal grooves, caliper cylinders and pistons with clean brake fluid.

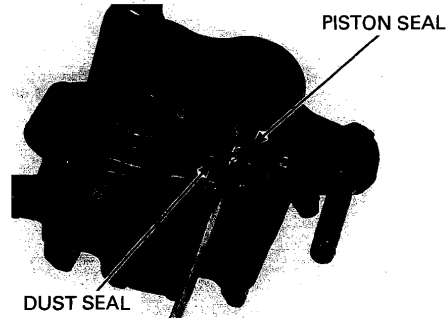

INSPECTION

Check the caliper cylinders for scoring, scratches or damage.

Measure the caliper cylinder I.D.

SERVICE LIMIT: 27.060 mm (1.0654 in)

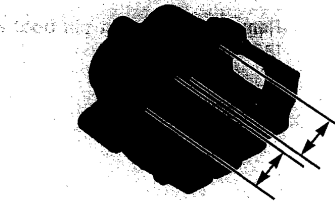

Check the caliper pistons for scoring, scratches or damage.

Measure the caliper piston O.D.

SERVICE LIMIT: 26.930 mm (1.0602 in)

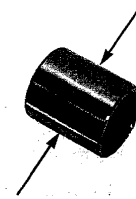

ASSEMBLY

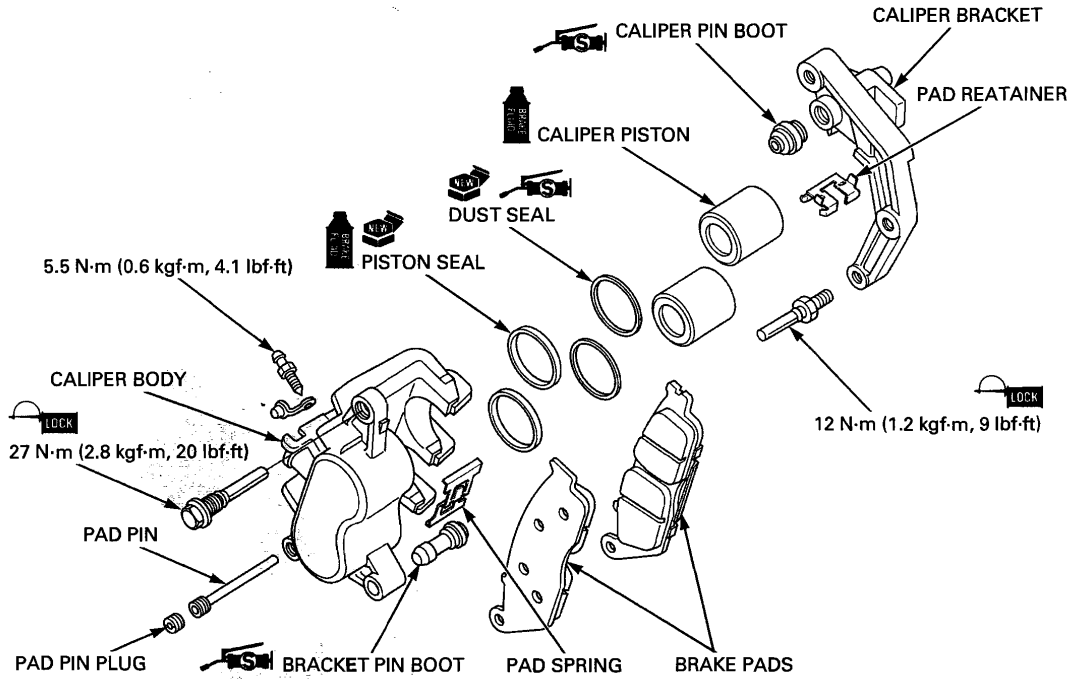

Coat new piston seals with clean brake fluid, new dust seals with silicone grease and install them into the seal grooves in the caliper.

Coat the caliper pistons with clean brake fluid and install them into the caliper cylinders with the opening toward the pads.

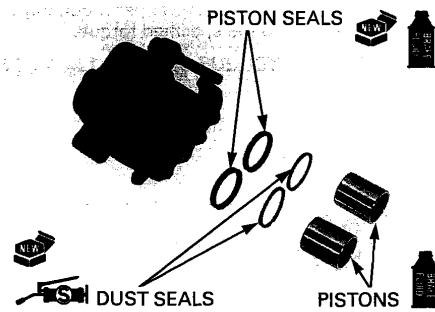

HYDRAULIC BRAKE

Check the caliper pin boot and replace it if it is hard, deteriorated or damaged.
Apply 0.4 g of silicone grease to the inside of the caliper pin boot.
Install the caliper pin boot in the bracket.
Apply Honda Bond A or equivalent to the pad retainer mating surface.
Install the retainer onto the bracket.

If the bracket pin is removed, apply locking agent to the threads and tighten it.

TORQUE: 12 N·m (1.2 kgf·m, 9 lbf·ft)

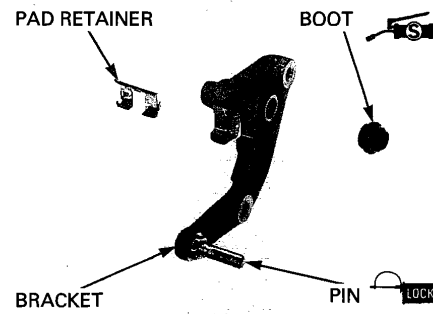

Check the bracket pin boot and replace it if it is hard, deteriorated or damaged.
Apply 0.4 g of silicone grease to the inside of the bracket pin boot.
Install the bracket pin boot and pad spring in the caliper.

If the caliper pin is removed, apply locking agent to the threads and tighten it.

TORQUE: 27 N·m (2.8 kgf·m, 20 lbf·ft)

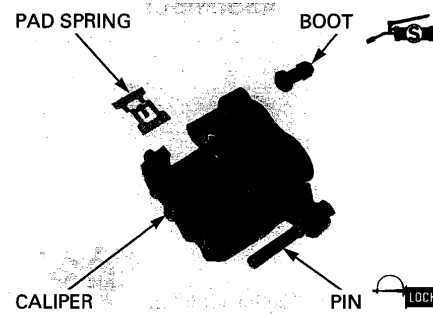

Install the caliper bracket to the caliper body.

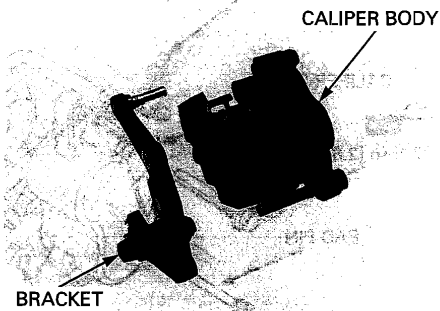

Install the brake caliper assembly so the disc is positioned between the pads, being careful not to damage the pads.

Install new caliper mounting bolts and tighten them to the specified torque.

TORQUE: 30 N·m (3.1 kgf·m, 22 lbf·ft)

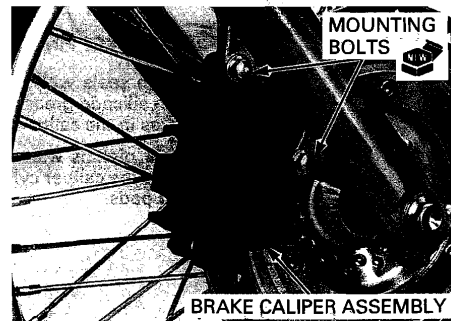

Connect the brake hose to the caliper body with the oil bolt and new sealing washers, and tighten the oil bolt to the specified torque.

TORQUE: 34 N·m (3.5 kgf·m, 25 lbf·ft)

Install the brake pads (page 17-7).

Fill and bleed the hydraulic system (page 17-5).

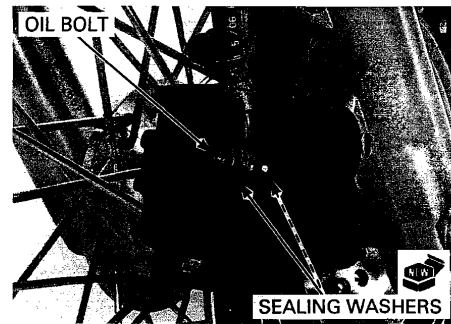

18. BATTERY/CHARGING SYSTEM

SYSTEM LOCATION.....	18-2	BATTERY	18-6
SYSTEM DIAGRAM.....	18-2	CHARGING SYSTEM INSPECTION.....	18-7
SERVICE INFORMATION	18-3	REGULATOR/RECTIFIER	18-8
TROUBLESHOOTING	18-5	ALTERNATOR CHARGING COIL	18-9

SYSTEM LOCATION

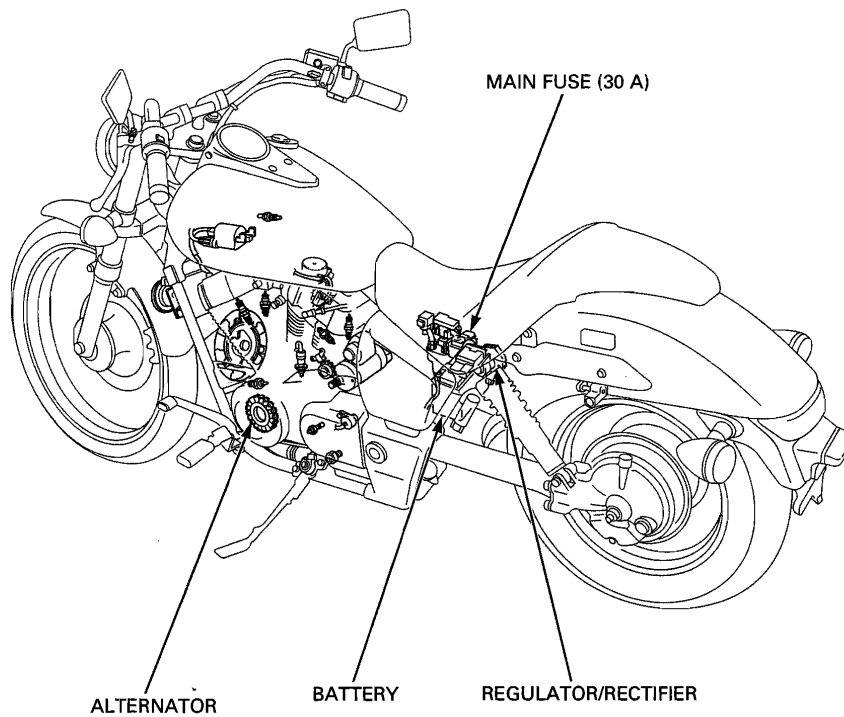

SYSTEM DIAGRAM

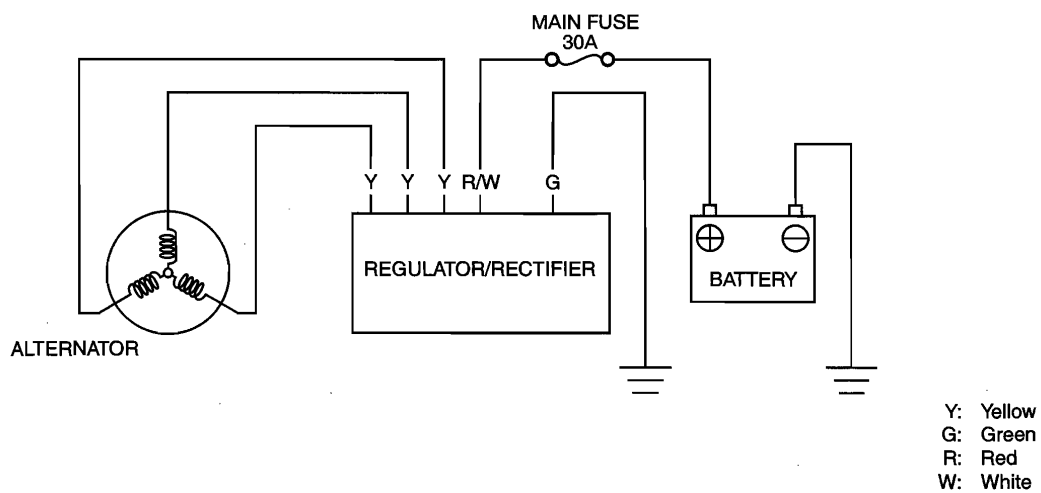

SERVICE INFORMATION**GENERAL****▲ WARNING**

- The battery gives off explosive gases; keep sparks, flames and cigarettes away. Provide adequate ventilation when charging.
- The battery contains sulfuric acid (electrolyte). Contact with skin or eyes may cause severe burns. Wear protective clothing and a face shield.
 - If electrolyte gets on your skin, flush with water.
 - If electrolyte gets in your eyes, flush with water for at least 15 minutes and call a physician immediately.
- Electrolyte is poisonous.
 - If swallowed, drink large quantities of water or milk and call your local Poison Control Center or call a physician immediately.

NOTICE

- *Always turn off the ignition switch before disconnecting any electrical component.*
- *Some electrical components may be damaged if terminals or connectors are connected or disconnected while the ignition switch is turned to ON and current is present.*
- For extended storage, remove the battery, give it a full charge, and store it in a cool, dry space.
- For a battery remaining in a stored motorcycle, disconnect the negative battery cable from the battery terminal.
- The battery sealing caps should not be removed. Attempting to remove the sealing caps from the cells may damage the battery.
- The maintenance free (MF) battery must be replaced when it reaches the end of its service life.
- The battery can be damaged if overcharged or undercharged, or if left to discharge for long period. These same conditions contribute to shortening the "life span" of the battery. Even under normal use, the performance of the battery deteriorates after 2 – 3 years.
- Battery voltage may recover after battery charging, but under heavy load, the battery voltage will drop quickly and eventually die out. For this reason, the charging system is often suspected as the problem. Battery overcharge often results from problems in the battery itself, which may appear to be an overcharging symptom. If one of the battery cells is shorted and battery voltage does not increase, the regulator/rectifier supplies excess voltage to the battery. Under these conditions, the electrolyte level goes down quickly.
- Before troubleshooting the charging system, check for proper use and maintenance of the battery. Check if the battery is frequently under heavy load, such as having the headlight and taillight ON for long periods of time without riding the motorcycle.
- The battery will self-discharge when the motorcycle is not in use. For this reason, charge the battery every 2 weeks to prevent sulfation from occurring.
- When servicing the charging system, always follow the steps in the troubleshooting flow chart (page 18-5).
- For alternator service (page 12-4).

BATTERY CHARGING

- Turn power ON/OFF at the charger, not at the battery terminal.
- For battery charging, do not exceed the charging current and time specified on the battery. Using excessive current or extending the charging time may damage the battery.
- Quick charging should only be done in an emergency; slow charging is preferred.

BATTERY TESTING

Refer to the battery tester's Operation Manual for the recommended battery tester for details about battery testing. The recommended battery tester puts a "load" on the battery so the actual battery condition of the load can be measured.

Recommended Battery Tester: BM-210-AH (U.S.A. only), BM-210 or BATTERY MATE (MTP08-0192, U.S.A. only) or equivalent

BATTERY/CHARGING SYSTEM

SPECIFICATIONS

ITEM		SPECIFICATIONS	
Battery	Capacity	12 V - 10 Ah or 12 V - 11 Ah	
	Current leakage	1 mA max.	
	Voltage (20°C/ 68°F)	Fully charged	13.0 - 13.2 V
		Needs charging	Below 12.4 V
	Charging current	Normal	1.1 A/5 - 10 h
Quick		5.5 A/1.0 h	
Alternator	Capacity	0.35 kW/5,000 rpm	
	Charging coil resistance (20°C/68°F)	0.1 - 1.0 Ω	

TORQUE VALUE

Battery case cover screw

1 N·m (0.1 kgf·m, 0.7 lbf·ft)

TOOLS

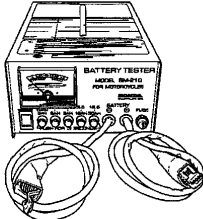
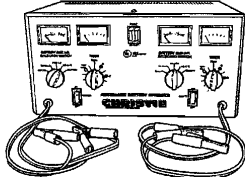
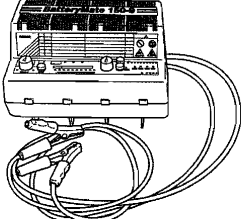
<p>Battery tester BM-210-AH (U.S.A. only)</p> 	<p>Christie battery charger MC1012/2 (U.S.A. only)</p> 	<p>Battery Mate tester/charger MTP08-0192 (U.S.A. only)</p> 
---	--	---

TROUBLESHOOTING**BATTERY IS DAMAGED OR WEAK****1. BATTERY TEST**

Remove the battery (page 18-6).

Check the battery condition using the recommended battery tester.

RECOMMENDED BATTERY TESTER: BM-210-AH (U.S.A. only), BM-210 or BATTERY MATE (MTP08-0192, U.S.A. only) or equivalent

Is the battery good condition?

NO - Faulty battery.

YES - GO TO STEP 2.

2. CURRENT LEAKAGE TEST

Install the battery (page 18-6).

Check the battery current leakage test (Leak test; page 18-7).

Is the current leakage below 1 mA?

YES - GO TO STEP 4.

NO - GO TO STEP 3.

3. CURRENT LEAKAGE TEST WITHOUT REGULATOR/RECTIFIER CONNECTOR

Disconnect the regulator/rectifier connector and recheck the battery current leakage.

Is the current leakage below 1 mA?

YES - Faulty regulator/rectifier.

NO -

- Shorted wire harness
- Faulty ignition switch

4. ALTERNATOR CHARGING COIL INSPECTION

Check the alternator charging coil (page 18-8).

Is the alternator charging coil resistance within 0.1 - 1.0 Ω (20°C/68°F)?

NO - Faulty charging coil.

YES - GO TO STEP 5.

5. CHARGING VOLTAGE INSPECTION

Measure and record the battery voltage using a digital multimeter (page 18-6).

Start the engine.

Measure the charging voltage (page 18-7).

Compare the measurements to result of the following calculation.

STANDARD: Measured battery voltage < Measured charging voltage < 15.5 V

Is the measured charging voltage within the standard voltage?

YES - Faulty battery.

NO - GO TO STEP 6.

6. REGULATOR/RECTIFIER SYSTEM INSPECTION

Check the voltage and resistance at the regulator/rectifier connectors (page 18-8).

Are the results of checked voltage and resistance correct?

YES - Faulty regulator/rectifier.

NO -

- Open circuit in related wire
- Loose or poor contacts of related terminal
- Shorted wire harness

BATTERY

REMOVAL/INSTALLATION

Remove the following:

- Seat (page 3-3)
- ICM (page 19-9)

Remove the screw.

Remove the battery case cover by unhooking the battery case hooks.

With the ignition switch turned to OFF, disconnect the battery negative (-) cable first, then disconnect the battery positive (+) cable.

Remove the battery from the battery case.

Install the battery in the reverse order of removal.

NOTE:

- Connect the positive (+) cable first, then connect the negative (-) cable.
- After connecting the battery cables, coat the terminals with grease.

TORQUE:

Battery case cover screw:
1 N-m (0.1 kgf-m, 0.7 lbf-ft)

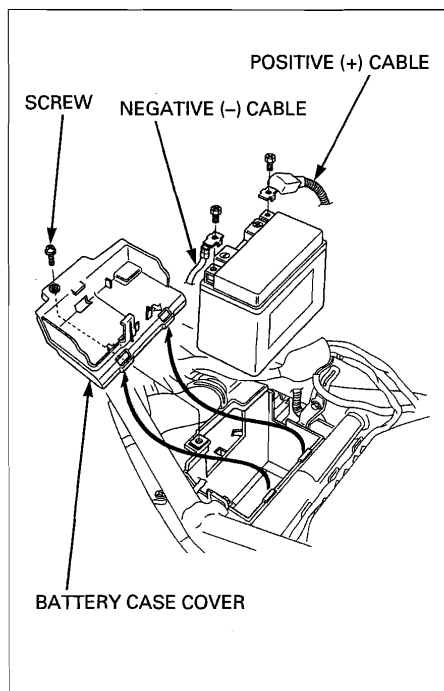

VOLTAGE INSPECTION

Remove the battery case cover (page 18-6).

Measure the battery voltage using a commercially available digital multimeter.

VOLTAGE (20°C/68°F): Fully charged: 13.0 – 13.2 V
Needs charging: Below 12.4 V

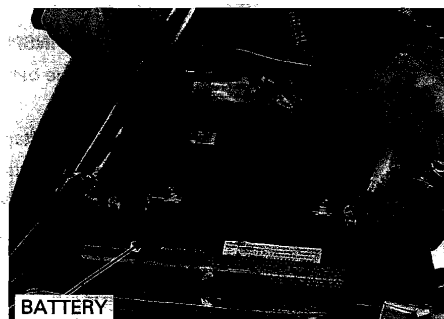

CHARGING SYSTEM INSPECTION

CURRENT LEAKAGE TEST

Remove the battery case cover (page 18-6).

With the ignition switch turned to OFF, disconnect the negative (-) cable from the battery.

Connect the ammeter (+) probe to the negative (-) cable and the ammeter (-) probe to the battery (-) terminal.

With the ignition switch turned to OFF, check for current leakage.

NOTE:

- When measuring current using a tester, set it to a high range, and then bring the range down to an appropriate level. Current flow higher than the range selected may blow the fuse in the tester.
- While measuring current, do not turn the ignition switch to ON. A sudden surge of current may blow the fuse in the tester.

SPECIFIED CURRENT LEAKAGE: 1 mA maximum

If current leakage exceeds the specified value, a shorted circuit is the probable cause.

Locate the short by disconnecting connections one by one and measuring the current.

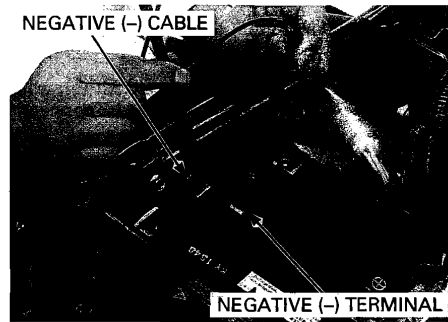

CHARGING VOLTAGE INSPECTION

NOTE:

Make sure the battery is in good condition before performing this test.

Connect a tachometer.

Start the engine and warm it up to the operating temperature; then stop the engine.

Remove the battery case cover (page 18-6). Connect the ICM 22P connector.

Connect the multimeter between the positive and negative terminals of the battery.

NOTE:

To prevent a short, make absolutely certain which are the positive and negative terminals or cable.

With the headlight on high beam, restart the engine. Measure the voltage on the multimeter when the engine runs at 5,000 rpm.

STANDARD:

- Measured BV < Measured CV < 15.5 V
- BV = Battery Voltage (page 18-6)
 - CV = Charging Voltage

Do not disconnect the battery or any cable in the charging system without first switching off the ignition switch. Failure to follow this precaution can damage the tester or electrical components.

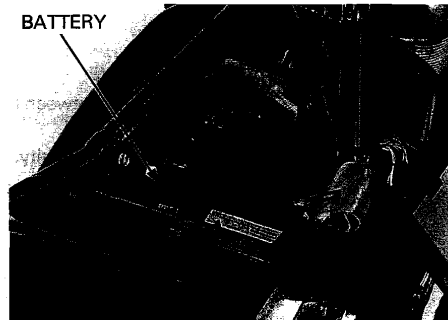

REGULATOR/RECTIFIER

WIRE HARNESS INSPECTION

BATTERY CHARGING LINE

Remove the right side cover (page 3-3).

With the ignition switch turned to OFF, disconnect the regulator/rectifier 5P connector.

Measure the voltage between the Red/white wire terminal (+) of the wire harness side connector and ground (-).
There should be battery voltage at all times.

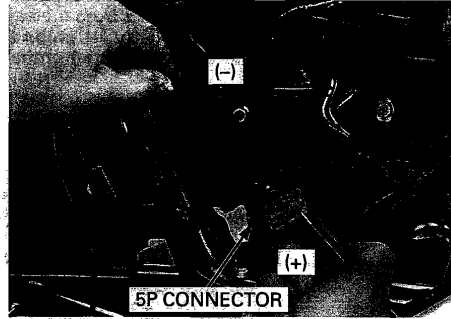

GROUND LINE

Check for continuity between the Green wire terminal of the wire harness side connector and ground. There should be continuity at all times.

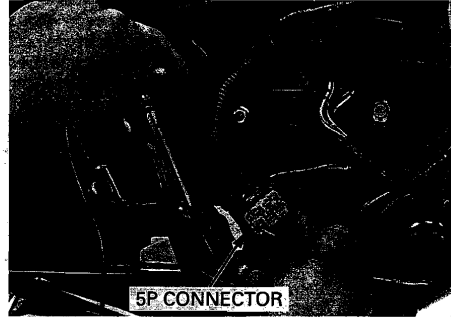

CHARGING COIL LINE

Check the continuity between the Yellow wire terminal and ground.

There should be no continuity.

Measure the resistance between the Yellow wire terminals.

STANDARD: 0.1 – 1.0 Ω at 20°C (68°F)

If the resistance measured at the regulator/rectifier 5P connector is abnormal, measure the resistance at the alternator 3P connector (page 18-9).

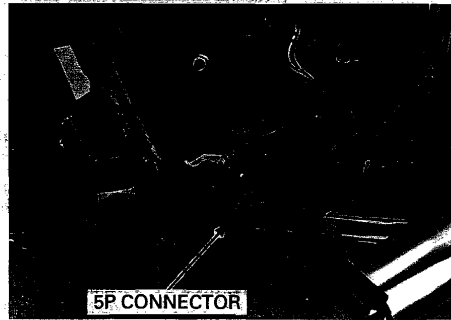

REMOVAL/INSTALLATION

Remove the right side cover (page 3-3)

With the ignition switch turned to OFF, disconnect the regulator/rectifier 5P connector.

Remove the nuts, regulator/rectifier and spacer.

Install the regulator/rectifier in the reverse order of removal.

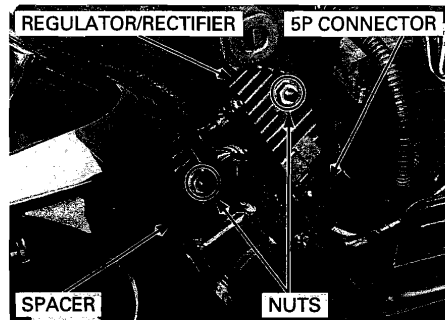
**ALTERNATOR CHARGING COIL****INSPECTION**

Remove the seat (page 3-3).

With the ignition switch turned to OFF, disconnect the alternator 3P (Natural) connector.

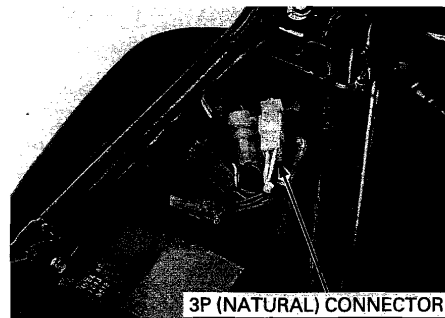

Measure the resistance between the Yellow wire terminals of alternator/stator side connector.

STANDARD: 0.1 – 1.0 Ω at 20°C (68°F)

Check for continuity between each wire terminals of the alternator/stator side connector and ground. There should be no continuity.

Replace the stator if the resistance is out of specification, or if any wire has continuity to ground.

For alternator/starter replacement (page 12-4).



19. IGNITION SYSTEM

SYSTEM LOCATION.....	19-2	IGNITION COIL	19-8
SYSTEM DIAGRAM.....	19-2	ICM	19-9
SERVICE INFORMATION	19-3	IGNITION TIMING	19-9
TROUBLESHOOTING	19-4	TP SENSOR	19-10
IGNITION SYSTEM INSPECTION	19-5		

IGNITION SYSTEM

SYSTEM LOCATION

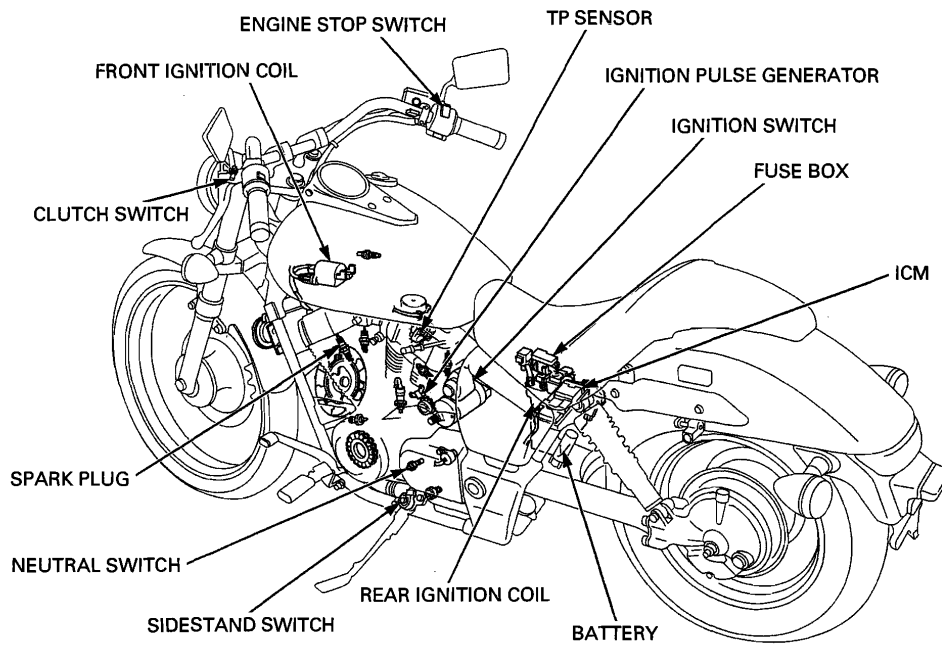

SYSTEM DIAGRAM

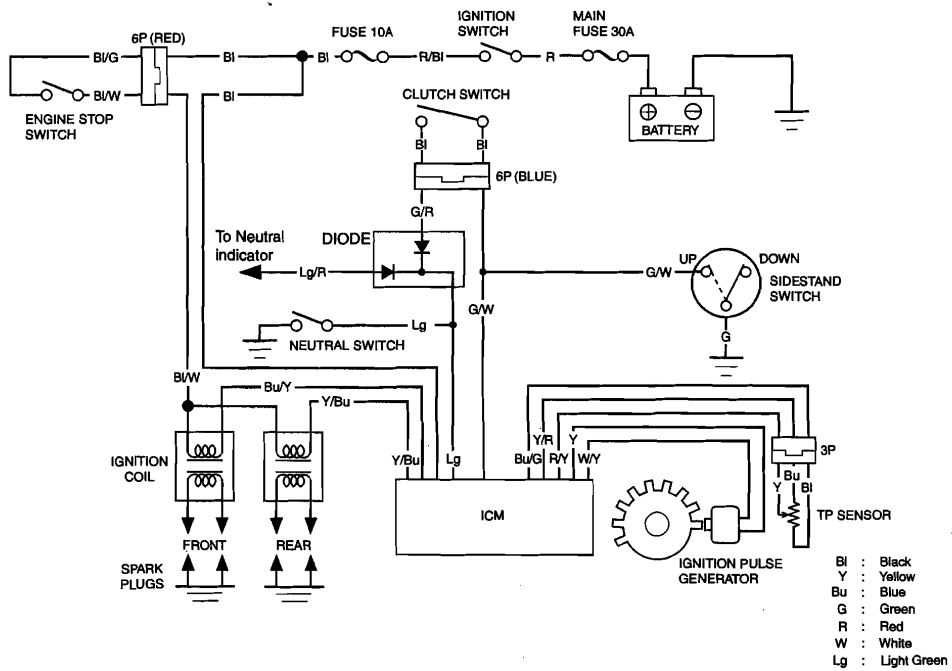

SERVICE INFORMATION

GENERAL

NOTICE

- The ICM may be damaged if dropped. Also, if the connector is disconnected when current is flowing, the excessive voltage may damage the ICM. Always turn the ignition switch to OFF before servicing.
- Use spark plugs with the correct heat range. Using spark plugs with an incorrect heat range can damage the engine.
- Some electrical components may be damaged if terminals or connectors are connected or disconnected while the ignition switch is turned to ON and current is present.
- When servicing the ignition system, always follow the steps in the troubleshooting table on page 19-4.
- The transistorized ignition system uses an electrically controlled ignition timing system. No adjustments can be made to the ignition timing.
- The ICM varies ignition timing according to the engine speed. The TP sensor signals the ICM to compensate the ignition timing according to the throttle opening.
- A faulty ignition system is often related to poor connections. Check those connections before proceeding.
- Make sure the battery is adequately charged. Using the starter motor with a weak battery results in a slower engine cranking speed as well as no spark at the spark plugs.
- For spark plug inspection (page 4-9).
- Refer to the following components informations:
 - Ignition switch (page 21-16)
 - Engine stop switch (page 21-17)
 - Neutral switch (page 21-19)
 - Sidestand switch (page 21-20)
 - Diode (page 20-16)

SPECIFICATIONS

ITEM		SPECIFICATIONS
Spark plug	Standard	DPR6EA-9 (NGK), X20EPR-U9 (DENSO)
	For extended high speed riding	DPR7EA-9 (NGK), X22EPR-U9 (DENSO)
Spark plug gap		0.8 - 0.9 mm (0.03 - 0.04 in)
Ignition coil primary peak voltage		100 V minimum
Ignition pulse generator peak voltage		0.7 V minimum
Ignition timing ("F" mark)		13° BTDC at idle
TP sensor	Resistance (20°C/68°F)	4 - 6 kΩ
	Input voltage	5 V

TORQUE VALUES

Alternator cover socket bolt
Timing hole cap

10 N·m (1.0 kgf·m, 7 lbf·ft)
10 N·m (1.0 kgf·m, 7 lbf·ft)

Apply grease to the threads

TOOLS

Peak voltage adaptor
07HGJ-0020100 (not available in
U.S.A.)

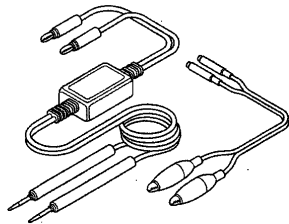

with commercially available digital
multimeter (impedance 10 MΩ/DCV
minimum) or peak voltage tester
(U.S.A. only)

IgnitionMate peak voltage tester
MTP07-0286(U.S.A. only)

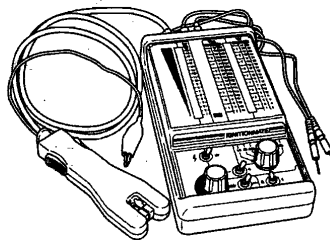

IGNITION SYSTEM

TROUBLESHOOTING

- Inspect the following before diagnosing the system.
 - Faulty spark plug
 - Loose spark plug cap or spark plug wire connection
 - Water in the spark plug cap (Leaking the ignition coil secondary voltage)
- If there is no spark at either cylinder, temporarily exchange the ignition coil with a known-good one and perform the spark test. If there is spark, the original ignition coil is faulty.
- "Initial voltage" of the ignition primary coil is the battery voltage with the ignition switch turned to ON and the engine stop switch at "O". (The engine is not cranked by the starter motor.)

No spark at spark plugs

UNUSUAL CONDITION		PROBABLE CAUSE (Check in numerical order)
Ignition coil primary voltage	No initial voltage with the ignition switch turned to ON and the engine stop switch at "O". (Other electrical components are normal)	<ol style="list-style-type: none"> 1. Faulty engine stop switch. 2. An open circuit in Black/white wire between the ignition coil and engine stop switch. 3. Loose or poor connection of the primary terminal, or an open circuit in the primary coil. 4. Faulty ICM (in case when the initial voltage is normal with the ICM connector disconnected).
	Initial voltage is normal, but it drops by 2 – 4 V while cranking the engine.	<ol style="list-style-type: none"> 1. Incorrect peak voltage adaptor connections. (System is normal if measured voltage is over the specifications with reverse connections.) 2. Battery is undercharged. (Voltage drops largely when the engine is started.) 3. No voltage at the Black wire of the ICM connector, or loose or poorly connected ICM connector. 4. Loose or poor connection or an open circuit in Blue/yellow or Yellow/blue wire between the ignition coils and ICM. 5. A short circuit in the ignition primary coil. 6. Faulty sidestand switch or neutral switch. 7. Loose or poor connection or an open circuit in No. 6 related wires. <ul style="list-style-type: none"> – Sidestand switch line: Green/white wire – Neutral switch line: Light green wire 8. Faulty ignition pulse generator. (Measure peak voltage.) 9. Faulty ICM (in case when above No. 1 through 8 are normal).
	Initial voltage is normal but there is no peak voltage while cranking the engine.	<ol style="list-style-type: none"> 1. Incorrect peak voltage adaptor connections. (System is normal if measured voltage is over the specifications with reverse connections.) 2. Faulty peak voltage adaptor. 3. Faulty ICM (in case when above No. 1 and 2 are normal).
	Initial voltage is normal but peak voltage is lower than the standard value.	<ol style="list-style-type: none"> 1. The multimeter impedance is too low; below 10 MΩ/DCV. 2. Cranking speed is too slow. (Battery is undercharged.) 3. The sampling timing of the tester and measured pulse were not synchronized. (System is normal if measured voltage is over the standard voltage at least once.) 4. Faulty ICM (in case when above No. 1 through 3 are normal).
	Initial and peak voltages are normal but no spark jumps.	<ol style="list-style-type: none"> 1. Faulty spark plug or leaking ignition coil secondary current ampere. 2. Faulty ignition coil(s).
Ignition pulse generator	Peak voltage is lower than the standard value.	<ol style="list-style-type: none"> 1. The multimeter impedance is too low; below 10 MΩ/DCV. 2. Cranking speed is too slow. (Battery is undercharged.) 3. The sampling timing of the tester and measured pulse were not synchronized. (System is normal if measured voltage is over the standard voltage at least once.) 4. Faulty ignition pulse generator (in case when above No. 1 through 3 are normal).
	No peak voltage.	<ol style="list-style-type: none"> 1. Faulty peak voltage adaptor. 2. Faulty ignition pulse generator.

IGNITION SYSTEM INSPECTION

NOTE:

- If no spark jumps at the plug, check all connections for loose or poor contact before measuring the peak voltage.
- Use a commercially available digital multimeter with an impedance of 10 M Ω /DCV minimum.
- The display value differs depending upon the internal impedance of the multimeter.

Connect the peak voltage adaptor to the digital multimeter or use the peak voltage tester.

TOOLS:

Peak voltage adaptor **07HGJ-0020100**
(not available in
U.S.A.)

with commercially available digital multimeter
(impedance 10 M Ω /DCV minimum) or
IgnitionMate peak voltage tester

MTP07-0286
(U.S.A. only)

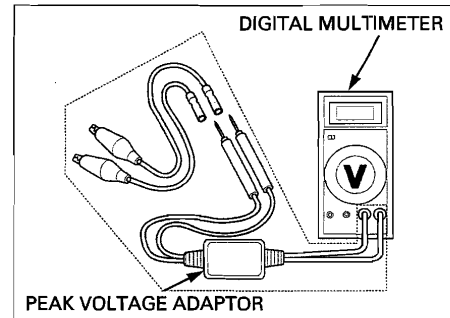

IGNITION COIL PRIMARY PEAK VOLTAGE

NOTE:

- Check all system connections before performing this inspection. Loose connectors can cause incorrect readings.
- Check that the cylinder compression is normal for each cylinder and the spark plugs are installed correctly in each cylinder head.

Disconnect all spark plug caps from the spark plugs. Connect the known-good spark plugs to all spark plug caps and ground them to the cylinder heads as done in a spark test.



IGNITION SYSTEM

FRONT: Remove the fuel tank (page 3-4).

REAR: Remove the following:

- Right side cover (page 3-3)
- Fuse box/turn signal relay (page 19-8)

With the ignition coil primary wires connected, connect the peak voltage tester or adaptor probes to the ignition coil primary terminal and ground.

TOOLS:

Peak voltage adaptor **07HGJ-0020100**
(not available in
U.S.A.)

with commercially available digital multimeter
(impedance 10 M Ω /DCV minimum) or
IgnitionMate peak voltage tester

MTP07-0286
(U.S.A. only)

CONNECTIONS:

FRONT: Blue/yellow (+) – ground (-)

REAR: Yellow/blue (+) – ground (-)

Turn the ignition switch to ON with the engine stop switch at "O".

Check the initial voltage at this time.

The battery voltage should be measured.

If the initial voltage cannot be measured, follow the checks in the troubleshooting table (page 19-4).

Shift the transmission into neutral.

Crank the engine with the starter motor and measure the ignition coil primary peak voltage.

PEAK VOLTAGE: 100 V minimum

NOTE:

Although measured values are different for each ignition coil, they are normal as long as voltage is higher than the specified value.

If the peak voltage is lower than the standard value, follow the checks in the troubleshooting table (page 19-4).

Install the removed parts in the reverse order of removal.

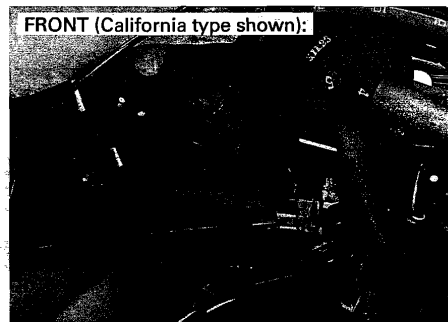

IGNITION PULSE GENERATOR PEAK VOLTAGE

NOTE:

Check that the cylinder compression is normal for each cylinder and the spark plug is installed correctly in the cylinder head.

Remove the ICM (page 19-9).

Connect the peak voltage tester or adaptor probes to the wire harness side ICM connector terminals.

TOOLS:

Peak voltage adaptor **07HGJ-0020100**
(not available in U.S.A.)

with commercially available digital multimeter
(impedance 10 M Ω /DCV minimum) or
IgnitionMate peak voltage tester

MTP07-0286
(U.S.A. only)

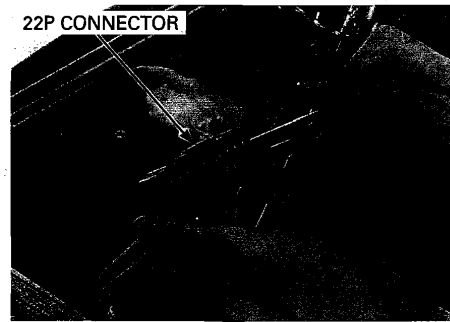

CONNECTION: White/yellow (+) – Yellow (–)

Turn the ignition switch to ON with the engine stop switch at "O".

Shift the transmission into neutral.

Crank the engine with the starter motor and measure the ignition pulse generator peak voltage.

PEAK VOLTAGE: 0.7 V minimum

If the voltage measured at the ICM connector is abnormal, measure the peak voltage at the ignition pulse generator connector.

Remove the steering side covers (page 3-5).

Turn the ignition switch to OFF.

Disconnect the ignition pulse generator 2P (Red) connector and connect the peak voltage tester or adaptor probes to the connector terminals of the ignition pulse generator side.

In the same manner as at the ICM connector, measure the peak voltage and compare it to the voltage measured at the ICM connector.

- If the peak voltage measured at the ICM is abnormal and the one measured at the ignition pulse generator is normal, the wire harness has an open or short circuit, or loose connection.
- If the peak voltage is lower than standard value, follow the checks in the troubleshooting table (page 19-4).

Install the removed parts in the reverse order of removal.

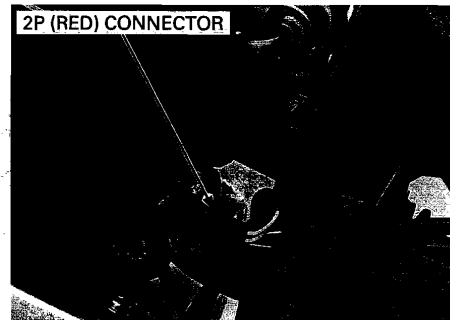

IGNITION SYSTEM

IGNITION COIL

FRONT IGNITION COIL

REMOVAL/INSTALLATION

Remove the following:

- Fuel tank (page 3-4)
- Steering side covers (page 3-5)

Disconnect the spark plug caps.

Disconnect the ignition coil primary wire connectors.

Remove the bolts, spacers and front ignition coil from the frame.

Install the front ignition coil in the reverse order of removal.

Route the spark plug wires properly (page 1-22).

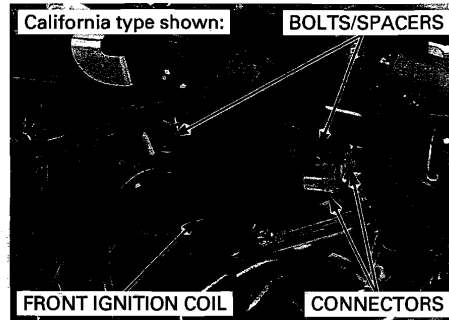

REAR IGNITION COIL

REMOVAL/INSTALLATION

Remove the right side cover (page 3-3).

Remove the fuse box/turn signal relay with the stay from the battery box by releasing their tabs.

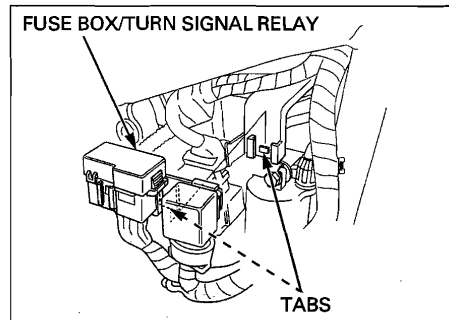

Disconnect the spark plug caps.

Disconnect the ignition coil primary wire connectors.

Remove the bolts, spacers and rear ignition coil from the bracket.

Install the rear ignition coil in the reverse order of removal.

Route the spark plug wires properly (page 1-22).

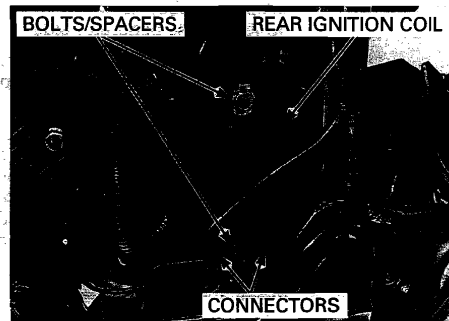

ICM

REMOVAL/INSTALLATION

Remove the seat (page 3-3).

Remove the ICM from the battery case cover and disconnect the ICM 22P connector.

Install the ICM in the reverse order of removal.

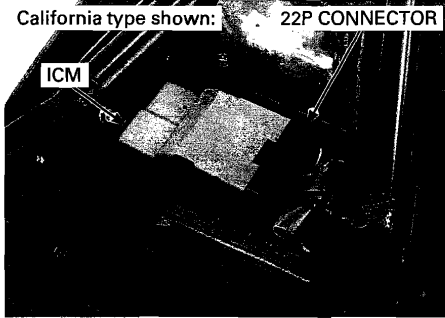

IGNITION TIMING

Start the engine, warm it up to normal operating temperature and then stop it.

Remove the socket bolts and alternator cover.

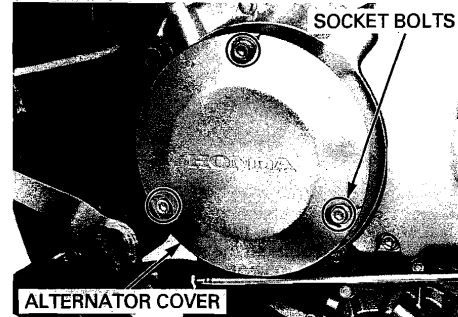

Remove the timing hole cap.

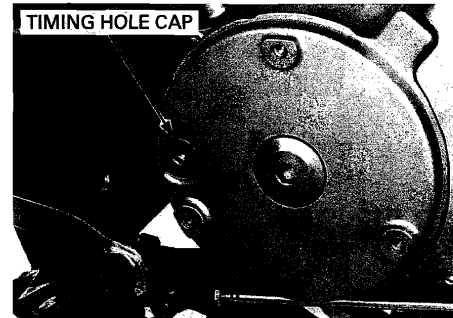

Connect a tachometer.

Read the manufacturer's instructions for timing light operation.

Connect the timing light to the front or rear spark plug wire.

Start the engine, let it idle and check the ignition timing.

IDLE SPEED: 1,200 ± 100 rpm

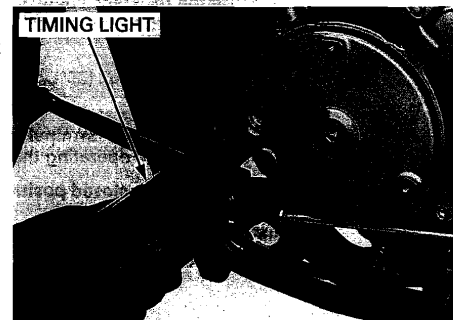

IGNITION SYSTEM

The timing is correct if the "F" mark on the flywheel aligns with the index notch on the left crankcase cover.

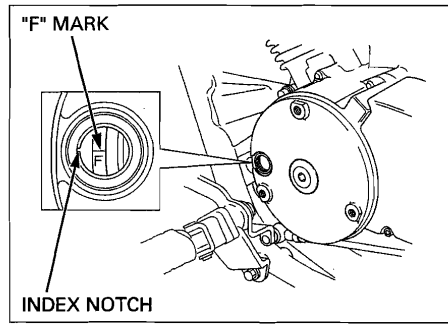

Coat a new O-ring with engine oil and install it into the timing hole cap groove. Apply grease to the threads of the timing hole cap. Install the timing hole cap and tighten it to the specified torque.

TORQUE: 10 N·m (1.0 kgf·m, 7 lbf·ft)

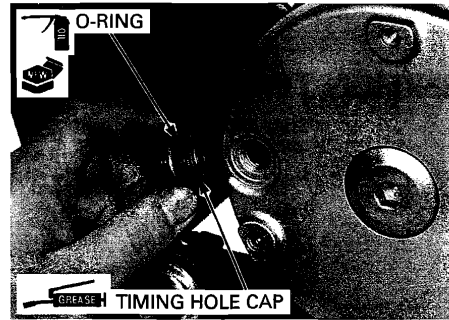

Install the alternator cover and tighten the socket bolts to the specified torque.

TORQUE: 10 N·m (1.0 kgf·m, 7 lbf·ft)

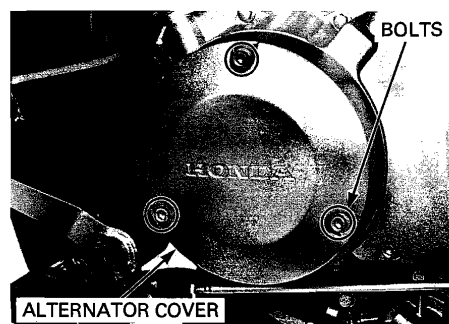

TP SENSOR

INSPECTION

Remove the ICM (page 19-9).

Measure the resistance between the Yellow/red and Blue/green wire terminals of the wire harness side connector.

STANDARD: 4 – 6 k Ω (20°C/68°F)

Check that the resistance between the Red/yellow and Blue/green wire terminals varies with the throttle position while operating the throttle grip.

Fully open – Fully closed position:

Resistance decreases

Fully closed – Fully open position:

Resistance increases



If the correct measurements cannot be obtained, remove the fuel tank (page 3-4).
Disconnect the TP sensor 3P connector.

Measure the resistance between the Blue and Black wire terminals of the TP sensor side connector.

STANDARD: 4 – 6 k Ω (20°C/68°F)

Check that the resistance between the Yellow and Black wire terminals varies with the throttle position while operating the throttle grip.

Fully open – Fully closed position:

Resistance decreases

Fully closed – Fully open position:

Resistance increases

- If the measurement at the ICM is abnormal and the one at the TP sensor is normal, check for an open or short circuit, or loose or poor connections in the wire harness.
- If both measurements are abnormal, remove the carburetor and replace the TP sensor (page 6-10).

Connect the ICM 22P connector.

Turn the ignition switch to ON with the engine stop switch at "O".

Measure the input voltage between the Yellow/red (+) and Blue/green (-) wire terminals of the wire harness side of the TP sensor 3P connector.

STANDARD: 5 V

If the input voltage is abnormal, or if there is no input voltage, check for an open or short circuit in the wire harness, or loose or poor ICM connector contact.

Install the removed parts in the reverse order of removal.

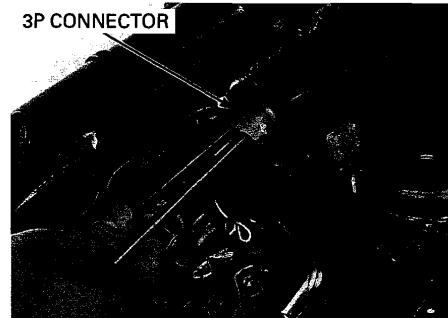
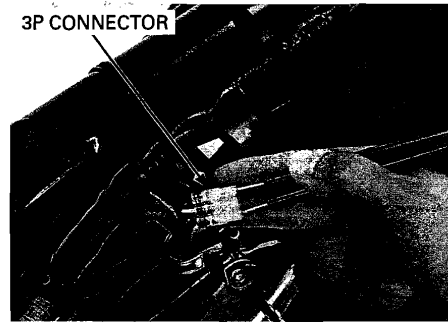

20. ELECTRIC STARTER

SYSTEM LOCATION.....	20-2	STARTER MOTOR.....	20-6
SYSTEM DIAGRAM.....	20-2	STARTER RELAY SWITCH.....	20-15
SERVICE INFORMATION	20-3	DIODE.....	20-16
TROUBLESHOOTING	20-4		

SYSTEM LOCATION

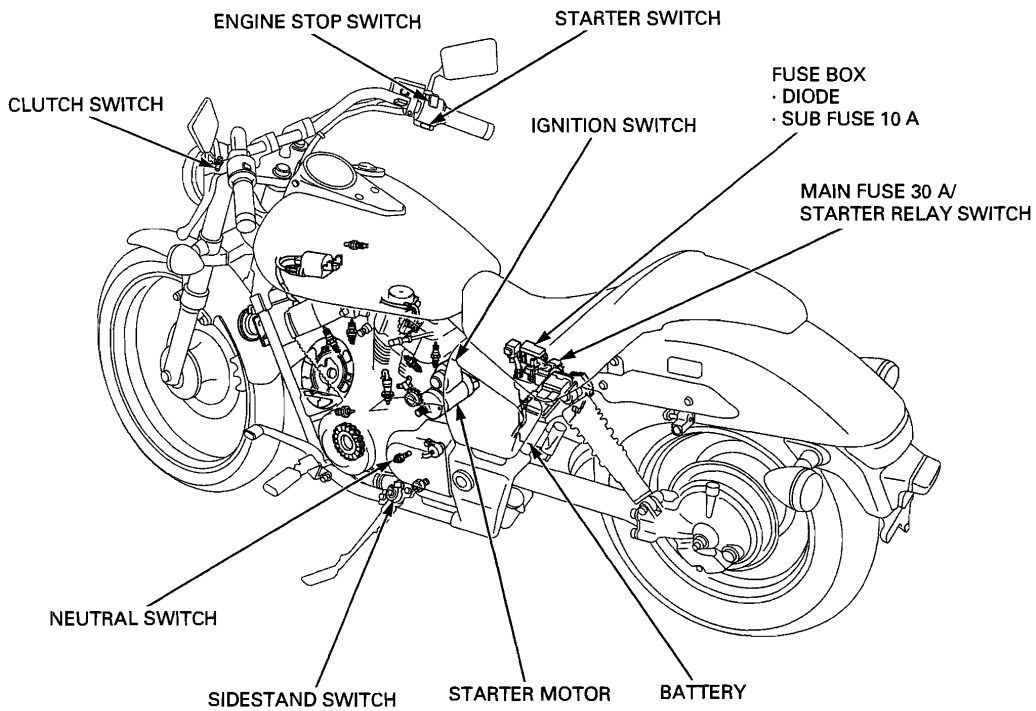

SYSTEM DIAGRAM

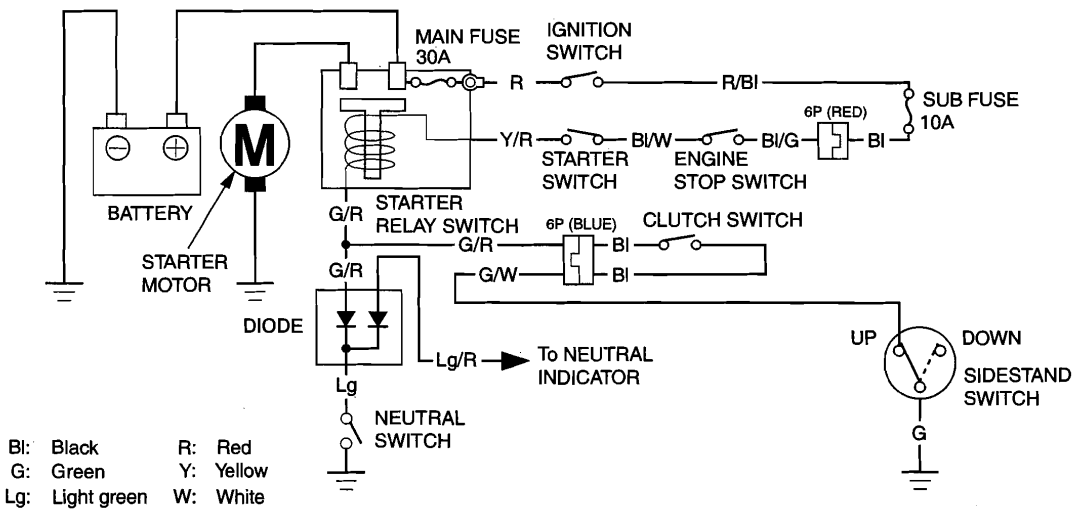

SERVICE INFORMATION**GENERAL****NOTICE**

- If the current is kept flowing through the starter motor to turn it while the engine is not cranking over, the starter motor may be damaged.
- Always turn the ignition switch to OFF before servicing the starter motor. The motor could suddenly start, causing serious injury.
- The starter motor can be serviced with the engine in the frame.
- When checking the starter system, always follow the steps in the troubleshooting flow chart (page 20-4).
- A weak battery may be unable to turn the starter motor quickly enough, or supply adequate ignition current.
- Refer to the following components information:
 - Ignition switch (page 21-16)
 - Engine stop switch (page 21-17)
 - Starter switch (page 21-17)
 - Neutral switch (page 21-19)
 - Sidestand switch (page 21-20)
 - Clutch switch (page 21-19)

SPECIFICATION

ITEM	STANDARD	Unit: mm (in)
		SERVICE LIMIT
Starter motor brush length	12.5 (0.49)	6.5 (0.26)

TORQUE VALUES

Starter motor cable terminal nut	10 N·m (1.0 kgf·m, 7 lbf·ft)
Starter motor assembly bolt	4.9 N·m (0.5 kgf·m, 3.6 lbf·ft)
Negative brush screw	3.7 N·m (0.4 kgf·m, 2.7 lbf·ft)

TROUBLESHOOTING

Starter motor does not turn

1. Fuse Inspection

Check for blown main fuse 30 A or sub fuse 10 A.

Is the fuse blown?

YES - Replace the fuse.

NO - GO TO STEP 2.

2. Battery Inspection

Make sure the battery is fully charged and in good condition (page 18-6).

Is the battery in good condition?

YES - GO TO STEP 3.

NO - Charge or replace the battery.

3. Starter Relay Switch Operation

Check the starter relay switch operation.

You should hear the relay "CLICK" when the starter switch button is depressed.

Is there a "CLICK"?

YES - GO TO STEP 4.

NO - GO TO STEP 5.

4. Starter Motor Inspection

Apply battery voltage directly to the starter motor and check the operation.

Does the starter motor turn?

YES -

- Poorly connected starter motor cable
- Faulty starter relay switch (page 20-15)

NO - Faulty starter motor (page 20-6).

5. Relay Coil Ground Lines Inspection

Disconnect the starter relay switch connector, and check the relay coil ground lines as below for continuity:

1. Green/red terminal - diode - neutral switch line (with the transmission in neutral and clutch lever released).

2. Green/red terminal - clutch switch - sidestand switch line (in any gear except neutral, and with the clutch lever pulled in and the sidestand up.

Is there continuity?

NO -

- Faulty neutral switch (page 21-19)
- Faulty diode (page 20-16)
- Faulty clutch switch (page 21-19)
- Faulty sidestand switch (page 21-20)
- Loose or poor contact connector
- Open circuit in wire harness

YES - GO TO STEP 6.

6. Starter Relay Voltage Inspection

Connect the starter relay switch connector.

With the ignition switch to ON and engine stop switch button "O" and the starter switch button pushed, measure the voltage at the starter relay switch connector (between Yellow/red (+) and body ground (-)).

Is there battery voltage?

NO -

- Faulty ignition switch (page 21-16)
- Faulty starter switch (page 21-17)
- Faulty engine stop switch (page 21-17)
- Loose or poor contact connector
- Open circuit in wire harness

YES - GO TO STEP 7.

7. Starter Relay Switch Continuity Inspection

Connect the starter relay switch connector.

Turn the ignition switch to ON and the engine stop switch "O", check for continuity at the starter relay switch terminals when the starter switch button is pushed.

Is there continuity?

NO – Faulty starter relay switch.

YES – Loose or poor contact starter relay switch connector.

The starter motor turns when the transmission is in neutral, but does not turn with the transmission in any position except neutral, with the sidestand up and the clutch lever pulled in.

1. Clutch Switch Inspection

Check the clutch switch operation (page 21-19).

Is the clutch switch operation normal?

NO – Faulty clutch switch.

YES – GO TO STEP 2.

2. Sidestand Switch Inspection

Check the sidestand switch operation (page 21-20).

Is the sidestand switch operation normal?

NO – Faulty sidestand switch (page 21-20).

YES – • Open circuit in wire harness
• Loose or poor contact connector

Starter motor turns slowly

- Low battery voltage
- Poorly connected battery terminal cable
- Poorly connected starter motor cable
- Faulty starter motor
- Poorly connected battery ground cable

Starter motor turns, but engine does not turn

- Starter motor is running backwards
 - Case assembled improperly
 - Terminals connected improperly
- Faulty starter clutch
- Damaged or faulty starter idle gear and/or reduction gear

Starter relay switch "Clicks", but engine does not turn over

- Crankshaft does not turn due to engine problems

STARTER MOTOR

REMOVAL

Disconnect the battery negative (-) cable (page 18-6).

Open the terminal cover and remove the terminal nut.
Disconnect the starter motor cable.

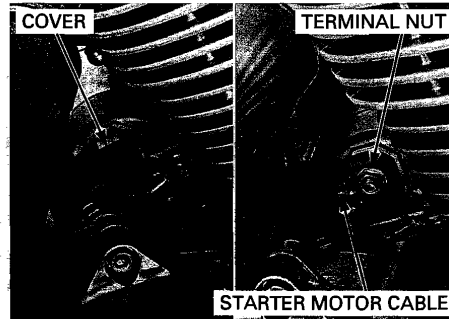

Remove the bolts and ground cable.
Remove the starter motor from the crankcase.

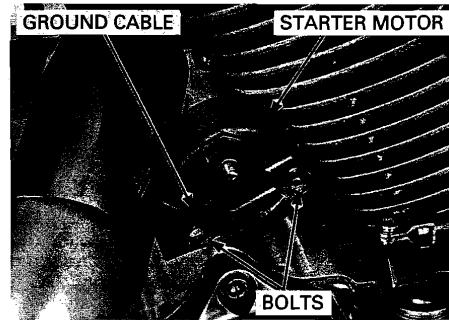

Remove the O-ring from the starter motor.

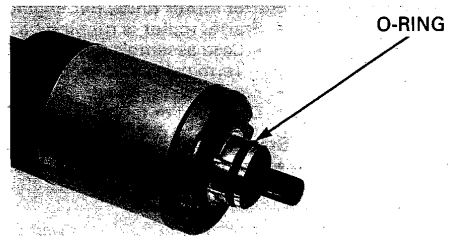

DISASSEMBLY/INSPECTION

Remove the assembly bolts and O-rings.

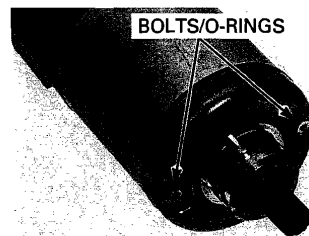

Remove the front cover and O-ring.

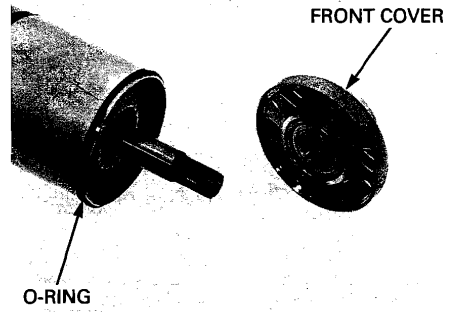

Remove the starter motor case and O-ring.
Remove the armature from the rear cover.

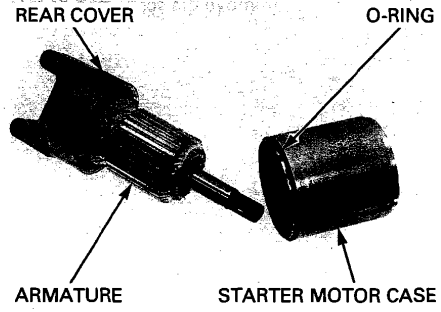

Remove the brushes and springs from the brush holder.
Remove the stopper from the rear cover.

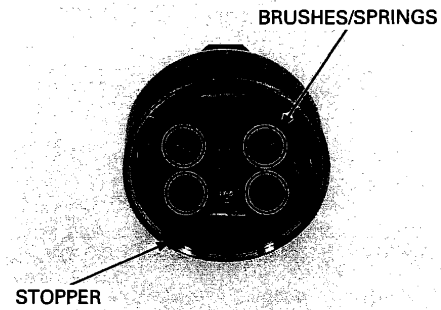

Check for continuity between starter motor cable terminal and positive brushes.
There should be continuity.

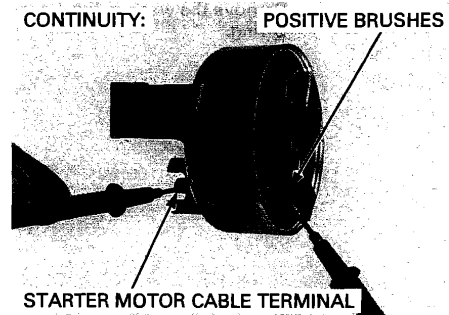

ELECTRIC STARTER

Check for continuity between positive brushes and rear cover.
There should be no continuity.

Check for continuity between negative brushes and rear cover.
There should be continuity.

Check for continuity between positive and negative brushes.
There should be no continuity.

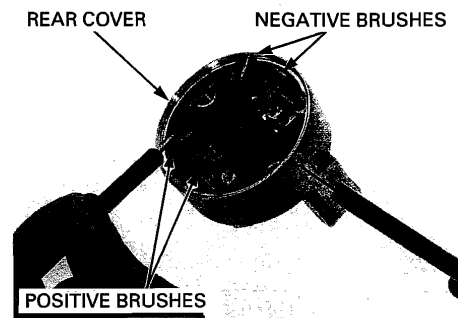

Remove the screw and negative brushes.

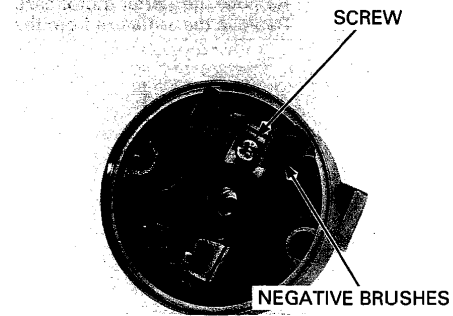

Remove the terminal nut.

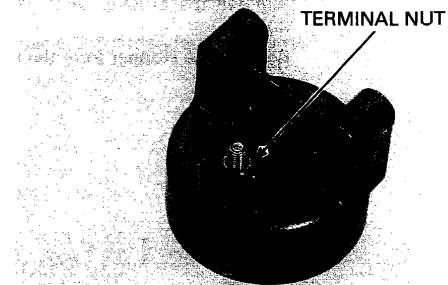

Remove the washer, insulator, terminal stopper and O-ring.

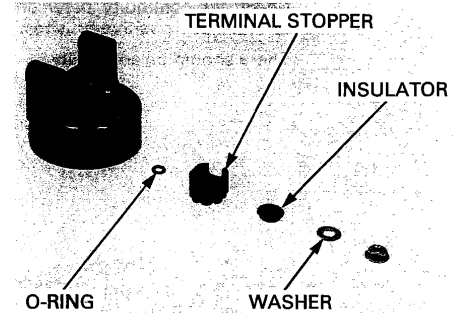

Remove the terminal bolt, positive brushes and brush holder.
Check the brush holder for crack or damage.

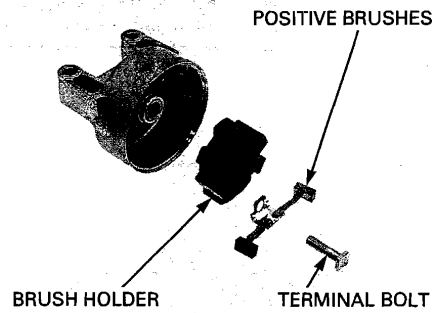

INSPECTION

Measure each brush length.

SERVICE LIMIT: 6.5 mm (0.26 in)

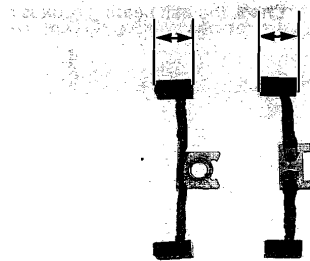

Check the commutator for damage or abnormal wear.
Do not use emery or sand paper on the commutator. Check the commutator bar for discoloration.
Clean the metallic debris off between commutator bars.
Replace the armature with a new one if necessary.

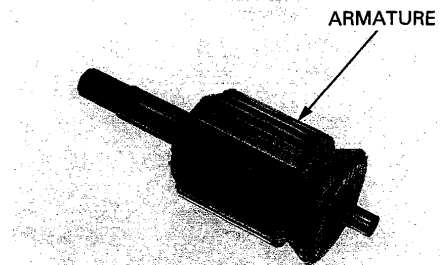

Check for continuity between pairs of commutator bars.
There should be continuity.

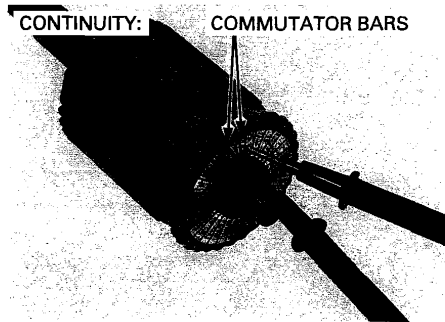

ELECTRIC STARTER

Check for continuity between each individual commutator bar and the armature shaft. There should be no continuity.

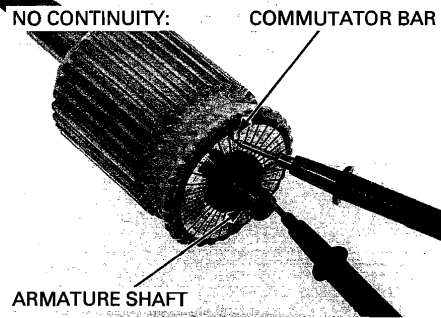

Check the dust seal and ball bearing for wear or damage. Check the ball bearing rotates smoothly.

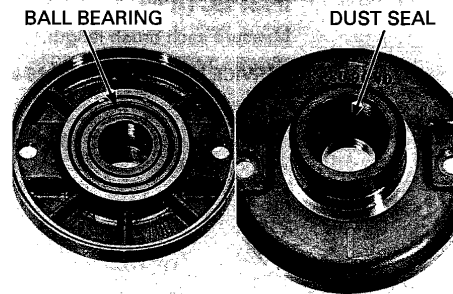

Check the bushing of the rear cover for wear or damage.

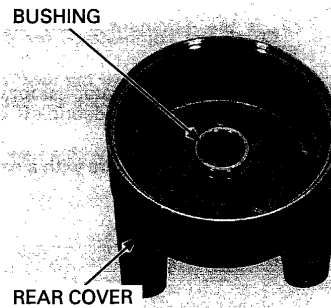

ASSEMBLY

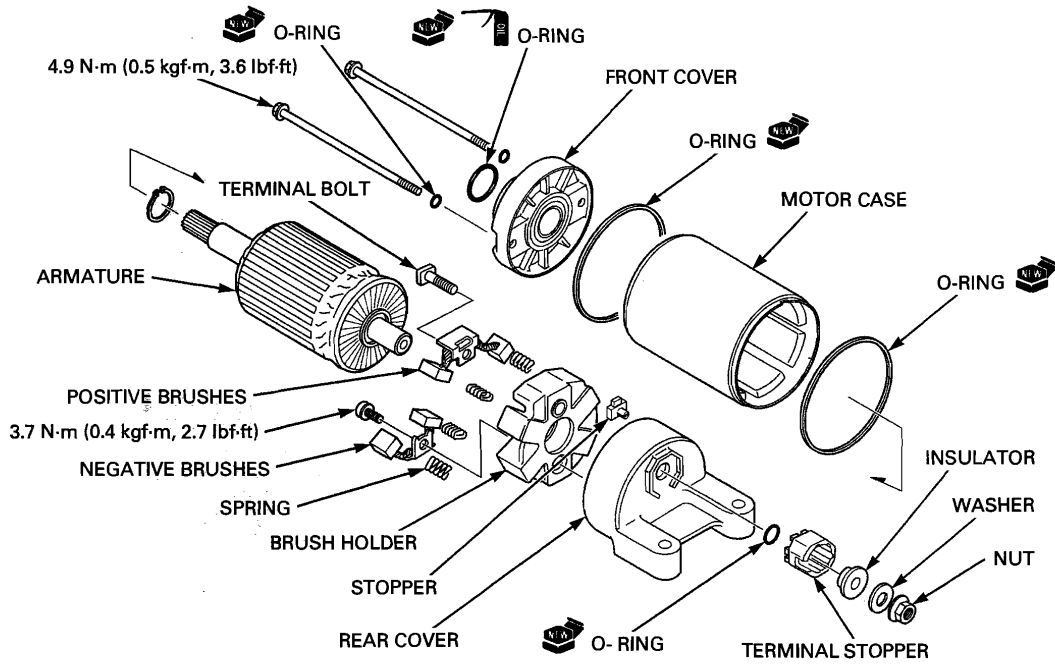

Install the brush holder, positive brushes and terminal bolt.

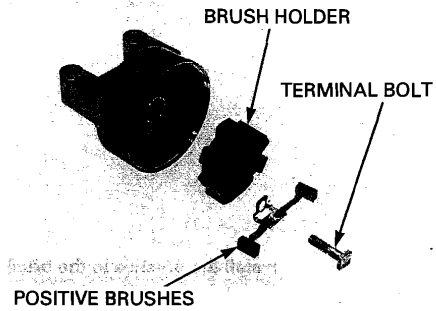

Install a new O-ring, terminal stopper, insulator and washer.

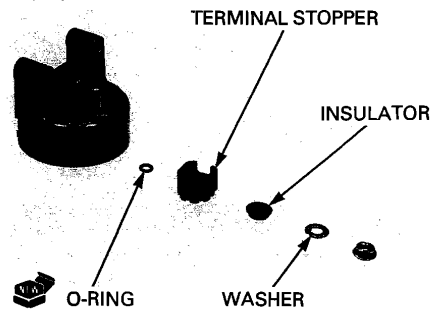

ELECTRIC STARTER

Install and tighten the terminal nut securely.

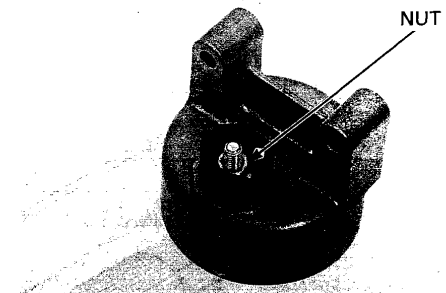

Install the negative brushes and tighten the screw to the specified torque.

TORQUE: 3.7 N-m (0.4 kgf-m, 2.7 lbf-ft)

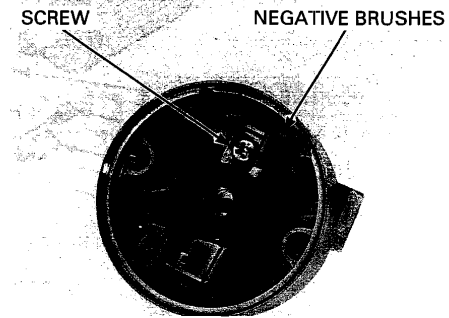

Install the brush springs to the brush holder grooves.

Install the stopper to the rear cover.

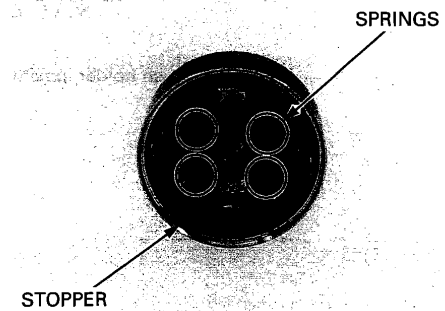

Install the brushes to the brush holder.

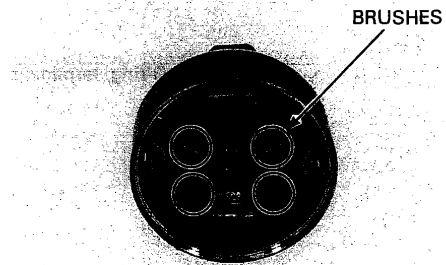

Install the armature to the rear cover assembly.

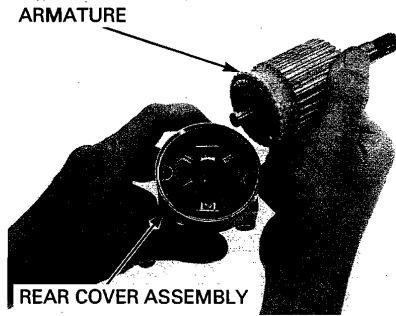

Install a new O-ring to the starter motor case.
Install the starter motor case with its groove with the stopper on the rear cover assembly.

NOTICE

The coil may be damaged if the magnet pulls the armature against the case.

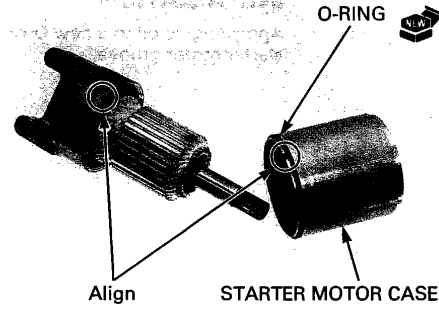

Install a new O-ring to the starter motor case.
Install the front cover to the starter motor case.

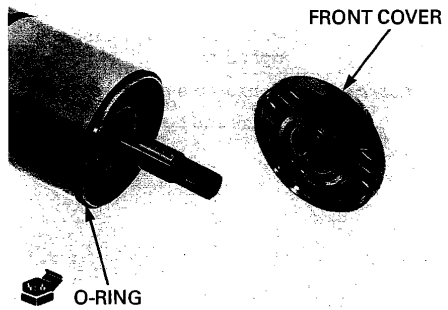

Align the index marks on the front cover, starter motor case and rear cover.

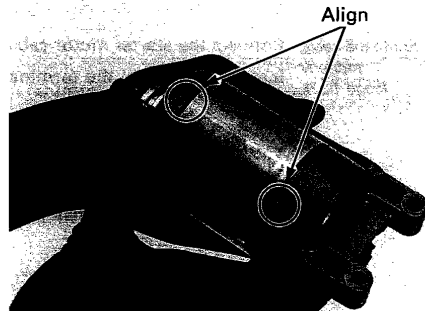

ELECTRIC STARTER

Install new O-rings to the assembly bolts.
Install and tighten the assembly bolts to the specified torque.

TORQUE: 4.9 N·m (0.5 kgf·m, 3.6 lbf·ft)

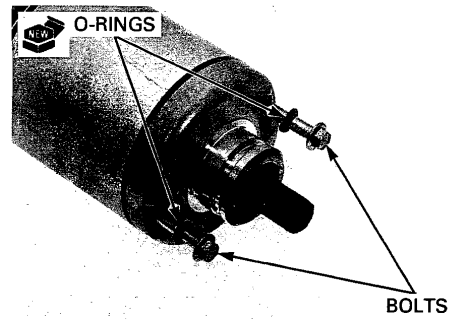

INSTALLATION

Apply engine oil to a new O-ring and install it to the starter motor groove.

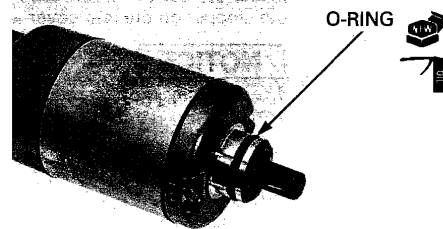

Install the starter motor onto the crankcase from the right side.

Route the cable properly (page 1-22).

Connect the ground cable.
Install and tighten the bolts securely.

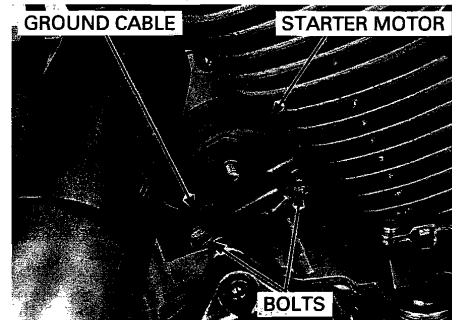

Route the cable properly (page 1-22).

Connect the starter motor cable.
Install and tighten the terminal nut to the specified torque.

TORQUE: 10 N·m (1.0 kgf·m, 7 lbf·ft)

Close the terminal cover.
Connect the battery negative (-) cable (page 18-6).

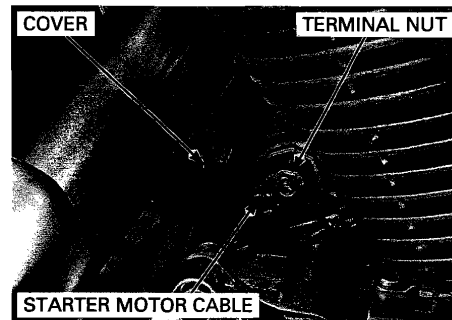

STARTER RELAY SWITCH

INSPECTION

Remove the following:

- Right side cover (page 3-3)
- Fuse box/turn signal relay (page 19-8)

Shift the transmission into neutral.

Turn the ignition switch to ON with the engine stop switch at "O".

Push the starter switch button.

The coil is normal if the starter relay switch clicks.

If you do not hear the switch "CLICK", inspect the relay switch using the procedure below.

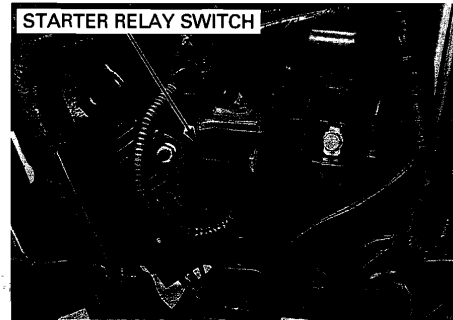

GROUND LINE

Disconnect the starter relay switch 4P connector. Check for continuity between the Green/red wire (ground line) terminal and ground.

If there is continuity when the transmission is in neutral or when the clutch is disengaged and the sidestand is retracted, the ground circuit of the relay coil is normal. (In neutral, there is a slight resistance due to the diode.)

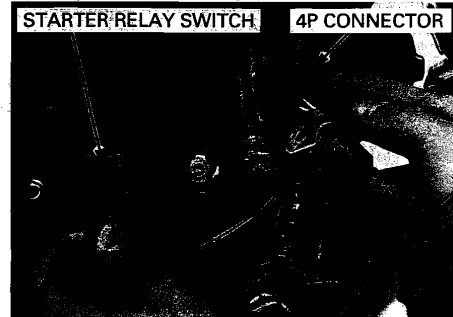

STARTER RELAY VOLTAGE

Connect the starter relay switch 4P connector.

Shift the transmission into neutral.

Turn the ignition switch to ON with the engine stop switch at "O".

Measure the voltage between the yellow/red wire terminal (+) and ground (-).

If the battery voltage appears when the starter switch button is pushed, the power supply circuit of the relay coil is normal.

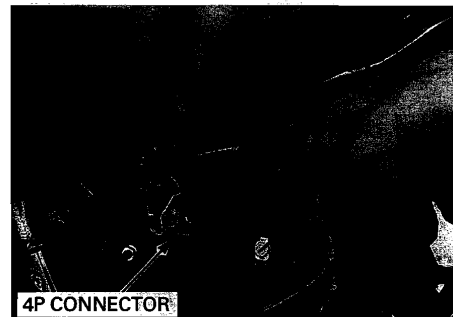

ELECTRIC STARTER

OPERATION CHECK

Remove the starter relay switch (page 20-16).

Connect a fully charged 12 V battery to the relay switch as shown.

There should be continuity between the cable terminals while the battery is connected, and no continuity when the battery is disconnected.

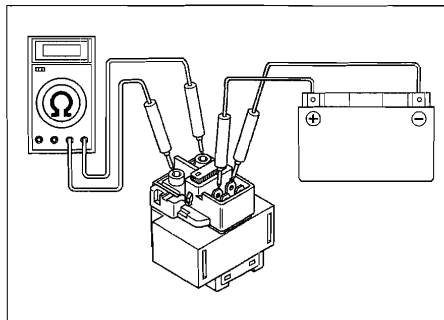

REMOVAL/INSTALLATION

Remove the following:

- Right side cover (page 3-3)
- Fuse box/turn signal relay (page 19-8)

Turn the ignition switch to OFF.

Disconnect the battery negative (-) cable (page 18-6).

Disconnect the starter relay 4P connector.

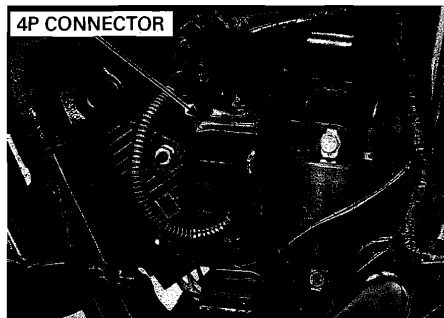

Remove the socket bolts and cables.

Remove the starter relay switch.

Installation is in the reverse order of removal.

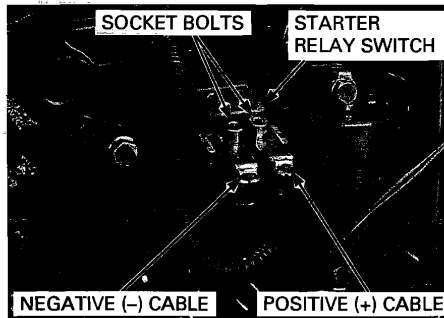

DIODE

INSPECTION

Remove the right side cover (page 3-3).

Open the fuse box cover and remove the diode.

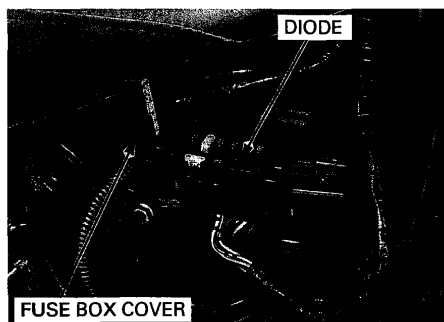

Check for continuity between the diode terminals.
When there is continuity, a small resistance value
will register.

If there is continuity in one direction, the diode is
normal.

DIODE

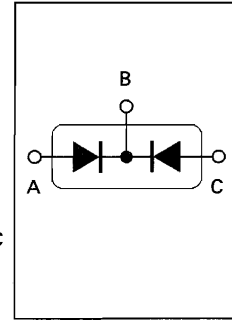
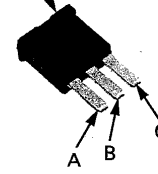

21. LIGHTS/METERS/SWITCHES

SYSTEM LOCATION.....	21-2	OIL PRESSURE INDICATOR	21-15
SERVICE INFORMATION	21-3	IGNITION SWITCH	21-16
HEADLIGHT.....	21-5	HANDLEBAR SWITCH	21-17
TURN SIGNAL LIGHT.....	21-6	BRAKE LIGHT SWITCH.....	21-18
BRAKE/TAIL LIGHT	21-7	CLUTCH SWITCH	21-19
LICENSE LIGHT.....	21-8	NEUTRAL SWITCH.....	21-19
SPEEDOMETER/VS SENSOR.....	21-9	SIDESTAND SWITCH.....	21-20
COOLANT TEMPERATURE INDICATOR/ ECT SENSOR SWITCH	21-12	HORN	21-21
FAN MOTOR SWITCH	21-14	TURN SIGNAL RELAY	21-21

LIGHTS/METERS/SWITCHES
SYSTEM LOCATION

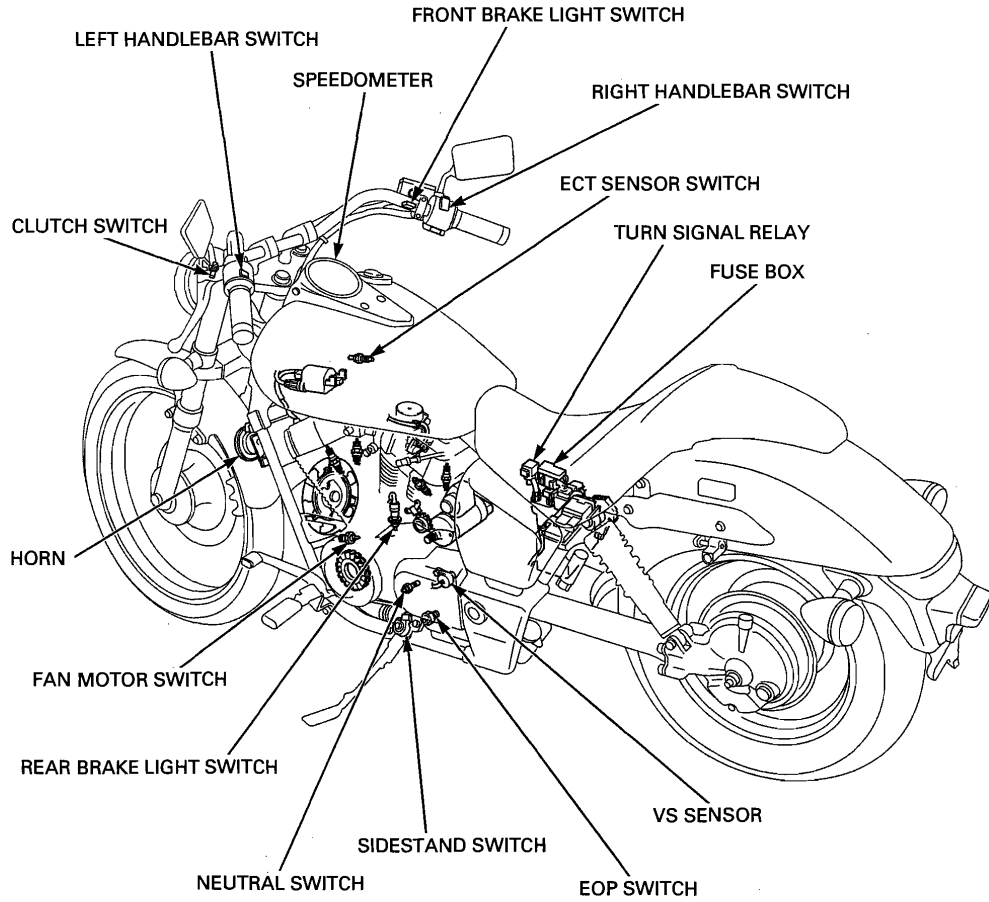

SERVICE INFORMATION**GENERAL****NOTICE**

- Note the following when replacing the halogen headlight bulb.
 - Wear clean gloves while replacing the bulb. Do not put fingerprints on the headlight bulb, as they may create hot spots on the bulb and cause it to fail.
 - If you touch the bulb with your bare hands, clean it with a cloth moistened with alcohol to prevent its early failure.
- Be sure to install the dust cover after replacing the bulb.
- A halogen headlight bulb becomes very hot while the headlight is on, and remains hot for a while after it is turned off. Be sure to let it cool down before servicing.
- Check the battery condition before performing any inspection that requires proper battery voltage.
- A continuity test can be made with the switches installed on the motorcycle.
- The following color codes used are indicated throughout this section.

Bu = Blue G = Green Lg = Light Green R = Red
 Bl = Black Gr = Gray O = Orange W = White
 Br = Brown Lb = Light Blue Y = Yellow

SPECIFICATIONS

ITEM		SPECIFICATIONS
Bulbs	Headlight	12 V – 60/55 W
	Brake/taillight	12 V – 21/5 W
	License light	12 V – 5 W
	Front turn signal/position light	12 V – 21/5 W x 2
	Rear turn signal light	12 V – 21 W x 2
	Instrument light	LED x 6
	Turn signal indicator	LED
	High beam indicator	LED
	Neutral indicator	LED
	Oil pressure indicator	LED
	Coolant temperature indicator	LED
Fuse	Main fuse	30 A
	Sub fuse	10 A x 5, 20 A x 1
ECT sensor switch	Start to close (ON)	112 – 118°C (234 – 244°F)
	Stop to open (OFF)	108°C (226°F) minimum
Fan motor switch	Start to close (ON)	103 – 107°C (217 – 225°F)
	Stop to open (OFF)	94 – 98°C (201 – 208°F)

TORQUE VALUES

ECT sensor switch	7 N·m (0.7 kgf·m, 5.2 lbf·ft)	Apply sealant to the threads
Fan motor switch	18 N·m (1.8 kgf·m, 13 lbf·ft)	
Ignition switch mounting bolt	12 N·m (1.2 kgf·m, 9 lbf·ft)	
Ignition switch cover screw	1 N·m (0.1 kgf·m, 0.7 lbf·ft)	
Neutral switch	12 N·m (1.2 kgf·m, 9 lbf·ft)	
Sidestand switch bolt	10 N·m (1.0 kgf·m, 7 lbf·ft)	ALOC bolt; replace with a new one
Horn mounting bolt	21 N·m (2.1 kgf·m, 15 lbf·ft)	
Speedometer mounting socket bolt	10 N·m (1.0 kgf·m, 7 lbf·ft)	
EOP switch terminal screw	1.9 N·m (0.2 kgf·m, 1.4 lbf·ft)	
Headlight unit mounting bolt	4.1 N·m (0.4 kgf·m, 3.0 lbf·ft)	
Brake/tail light mounting nut	6.3 N·m (0.6 kgf·m, 4.6 lbf·ft)	
VS sensor mounting bolt	9.8 N·m (1.0 kgf·m, 7.2 lbf·ft)	

TOOL

Inspection test harness
07GMJ-ML80100

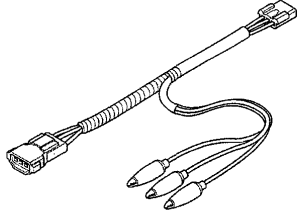

HEADLIGHT

BULB REPLACEMENT

Remove the bolts, collars and headlight unit from the headlight case.

Disconnect the headlight 3P connector.

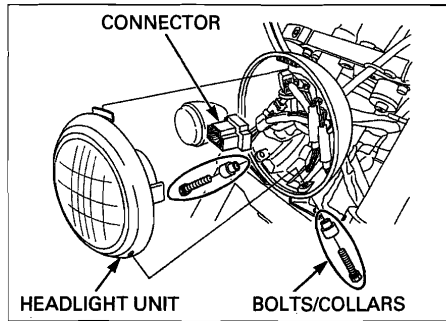

Remove the dust cover.

Unhook the retainer and remove the bulb.

NOTICE

Avoid touching the halogen headlight bulb. Finger prints can create hot spots that cause a bulb to break.

Install a new bulb, aligning its tabs with the grooves in the headlight unit.

Hook the retainer.

Install the dust cover with its "TOP" mark facing up.

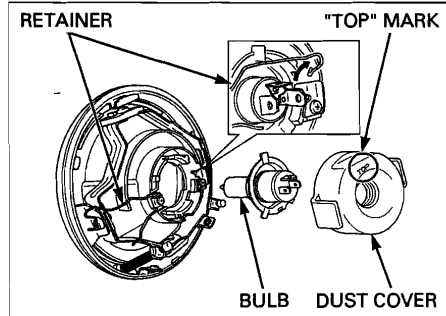

Connect the headlight 3P connector.

Install the headlight unit into the headlight case by aligning the headlight unit hook with the headlight case tab.

Install the collars and bolts.

Tighten the bolts to the specified torque.

TORQUE: 4.1 N-m (0.4 kgf-m, 3.0 lbf-ft)

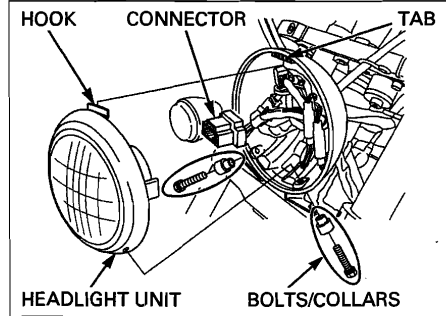

HEADLIGHT CASE REMOVAL/INSTALLATION

Remove the following:

- Headlight unit (page 21-5)
- Front turn signal light (page 21-6)

Release the wire harnesses from the clamps. Remove the wire harnesses from the headlight case.

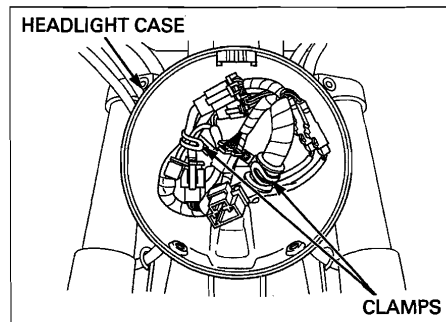

LIGHTS/METERS/SWITCHES

Remove the nuts, bolts and headlight case from the brackets.

Route the wire harnesses properly (page 1-22).

Install the headlight case in the reverse order of removal.

Adjust the headlight aim (page 4-22).

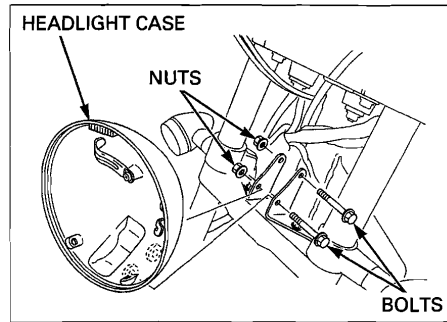

TURN SIGNAL LIGHT

BULB REPLACEMENT

Remove the screw and turn signal light lens. While pushing the bulb in, turn it counterclockwise to remove it, and replace it with a new one.

Make sure the lens gasket is installed in position and is in good condition, and replace it with a new one if necessary.

Install the lens, aligning its slot with the tab of the turn signal light, and tighten the screw.

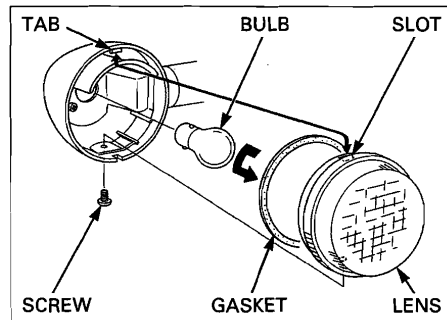

REMOVAL/INSTALLATION

FRONT

Remove the headlight unit (page 21-5).

Disconnect the turn signal 3P connectors.

- Light blue: Right turn signal connector
- Orange: Left turn signal connector

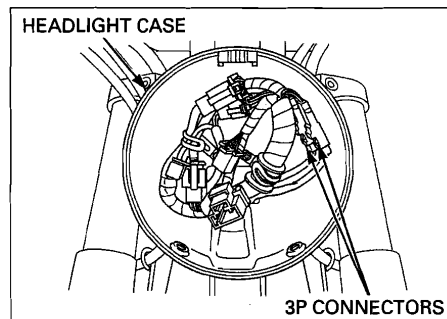

Remove the bolt, collar and turn signal light.

Installation is in the reverse order of removal.

Route the turn signal wire properly (page 1-22).

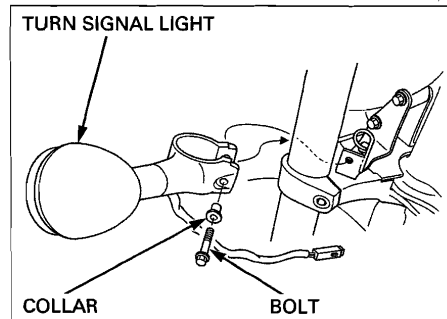

REAR

Remove the rear frame/rear fender A (page 3-7).

Release the turn signal light wire from the clamps of the rear frame.

Remove the bolt and turn signal light from the rear frame.

Install the turn signal light, aligning its tab with the rear frame slot and tighten the bolt.

Install the rear frame/rear fender A (page 3-7).

Route the turn signal light wire properly (page 1-22).

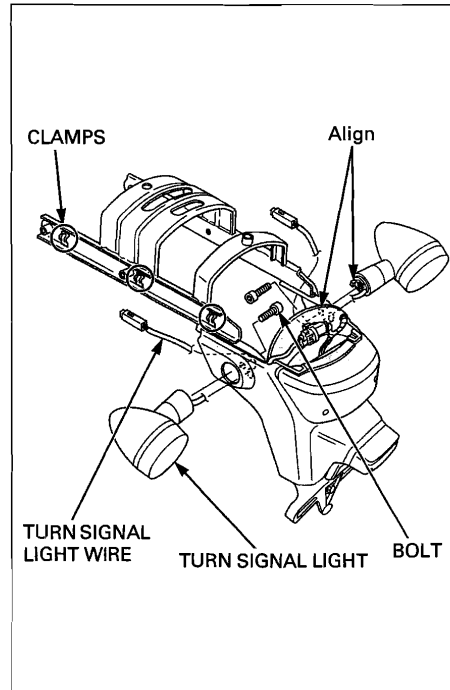

BRAKE/TAIL LIGHT

BULB REPLACEMENT

Remove the screws.

Remove the brake/tail light lens while pushing it down and release its tabs from the rear fender A.

While pushing in the bulb, turn it counterclockwise to remove it, and replace it.

Make sure that the lens gasket is installed in position and is in good condition, and replace it with a new one if necessary.

Install the removed parts in the reverse order of removal.

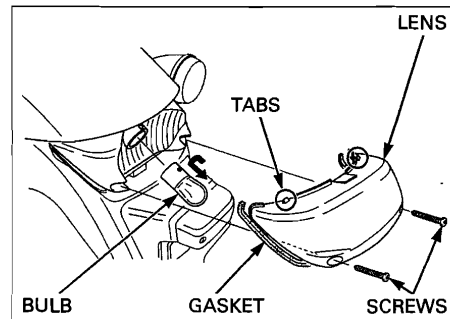

REMOVAL/INSTALLATION

Remove the rear frame/rear fender A (page 3-7).
Release the brake/tail/license light wire from the clamps of the rear frame.
Disconnect the license light 2P connector and remove it from the rear fender A.
Remove the nuts, collars and brake/tail light.

Route the wires properly (page 1-22).

Installation is in the reverse order of removal.

TORQUE:

Brake/tail light mounting nut:
6.3 N·m (0.6 kgf·m, 4.6 lbf·ft)

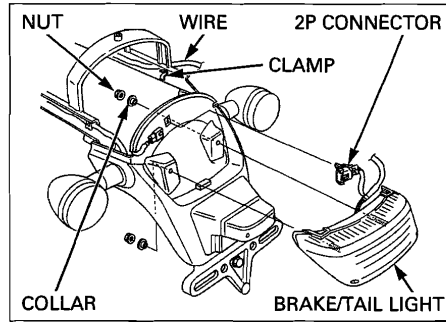

LICENSE LIGHT

BULB REPLACEMENT

Remove the screws and license light cover.
Remove the bulb and replace it.
Make sure that the lens gasket is installed in position and is in good condition, and replace it with a new one if necessary.
Install the removed parts in the reverse order of removal.

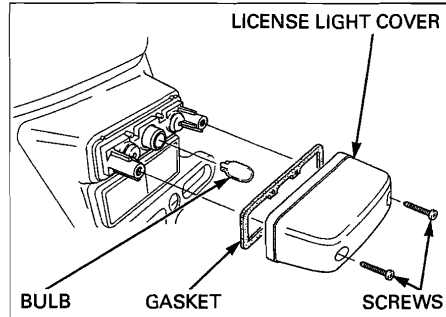

REMOVAL/INSTALLATION

Remove the rear frame/rear fender A (page 3-7).
Disconnect the license light 2P connector.
Remove the nuts, collars, clamp and license light.

Route the wires properly (page 1-22).

Installation is in the reverse order of removal.

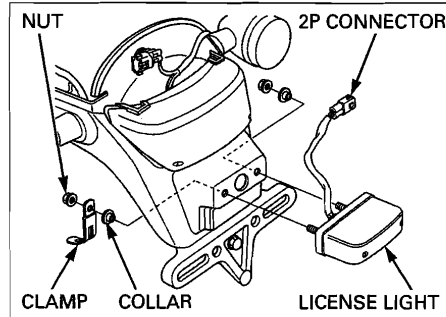

SPEEDOMETER/VS SENSOR

POWER/GROUND LINE INSPECTION

Remove the speedometer assembly (page 21-10).

POWER INPUT LINE

Measure the voltage between the Brown wire terminal (+) of the speedometer 12P connector and ground (-).

There should be battery voltage with the ignition switch turned to ON.

If there is no voltage, check the following:

- Open circuit in the Brown wire
- Blown sub fuse 10 A (METER, TAIL)

GROUND LINE

Check for continuity between the Green/black wire terminal and ground.

There should be continuity at all times.

If there is no continuity, check for an open circuit in the Green/black wire.

BACK-UP VOLTAGE LINE

Check this line if the odometer/trip meter does not function.

Measure the voltage between the Pink wire terminal (+) and ground (-).

There should be battery voltage at all times.

If there is no voltage, check the following:

- Open circuit in the Pink wire
- Blown sub fuse 10 A (ODOMETER)
- Open circuit in the Red wire

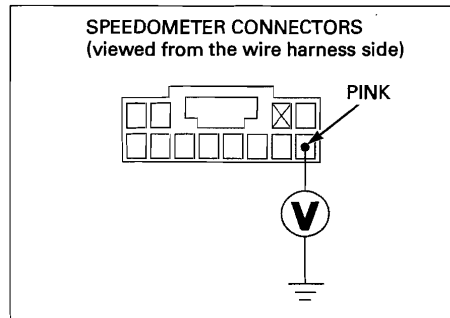
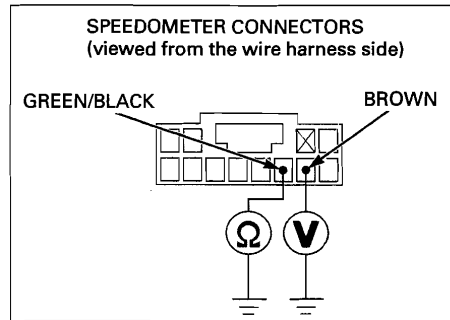

SPEEDOMETER INSPECTION

Speedometer does not operate

Check that the indicators function properly.

If they do not function, check the power/ground line (page 21-9).

Remove the speedometer assembly (page 21-10).

Support the motorcycle securely and raise the rear wheel off the ground.

Shift the transmission into neutral and turn the ignition switch to ON.

Measure the voltage between the Black/yellow (+) and Green/black (-) wire terminals of the speedometer connector.

Slowly turn the rear wheel by hand.

There should be 0 V to 5 V pulse voltage.

- If pulse voltage appears, replace the speedometer.
 - If pulse voltage does not appear, check the following:
 - Black/yellow wire for an open or short circuit.
 - Green/black wire for an open circuit.
- If the wires are OK, check the VS sensor (page 21-11).

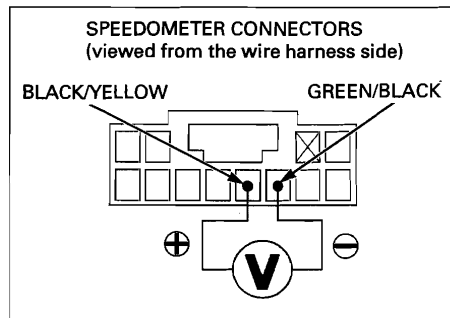

**SPEEDOMETER REMOVAL/
INSTALLATION**

Remove the bolts and speedometer assembly from the fuel tank.

Slide the dust cover and disconnect the speedometer 12P connector.

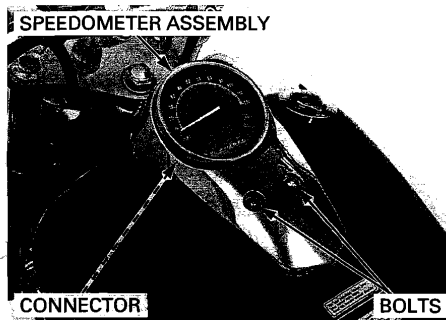

Remove the screws, switch cover and trip meter reset switch.

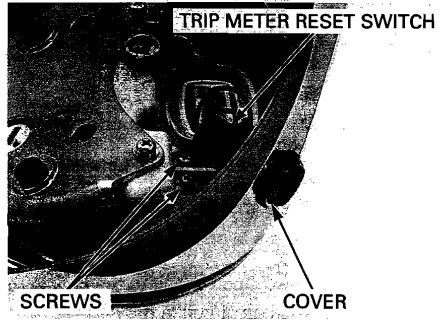

Remove the screws, clamp, speedometer and O-ring.

Check the O-ring is in good condition, replace it if necessary.

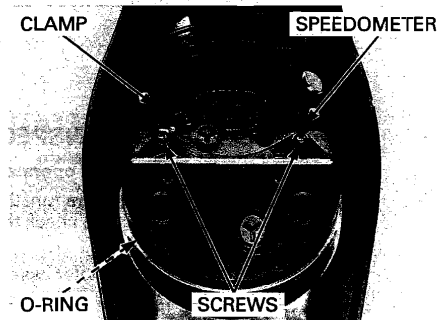

Install the removed parts into the speedometer cover in the reverse order of removal.

NOTE:
Install the reset switch with its boss facing down.

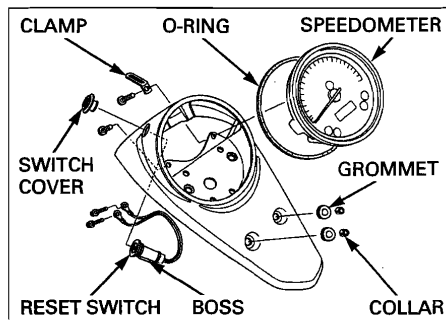

Connect the speedometer 12P connector and install the dust cover.

Install the speedometer assembly on the fuel tank, aligning the fuel tank tab with the meter slot.

Install and tighten the bolts to the specified torque.

TORQUE: 10 N·m (1.0 kgf·m, 7 lbf·ft)

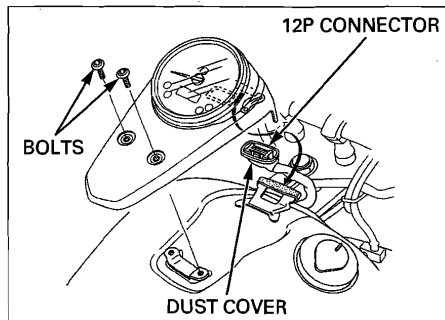

VS SENSOR INSPECTION

Remove the seat (page 3-3).

Disconnect the VS sensor 3P (Natural) connector.

Turn the ignition switch to ON and measure the voltage at 3P (Natural) connector of the wire harness side.

CONNECTION: Brown (+) – Green/Black (-)

STANDARD: Battery voltage

There should be battery voltage.

If there is no voltage, check for an open circuit in the Brown and Green/black wires.



Support the motorcycle securely and raise the rear wheel off the ground.

Connect the test harness between the VS sensor 3P (Natural) connector.

TOOL:

Inspection test harness 07GMJ-ML80100

Measure the voltage between the Red clip (+) and White clip (-).

CONNECTION: Red clip (+) – White clip (-)

STANDARD: Repeat 0 to 5 V

Shift the transmission into neutral and turn the ignition switch to ON.

Slowly turn the rear wheel by hand.

If pulse voltage does not appear, replace the VS sensor.

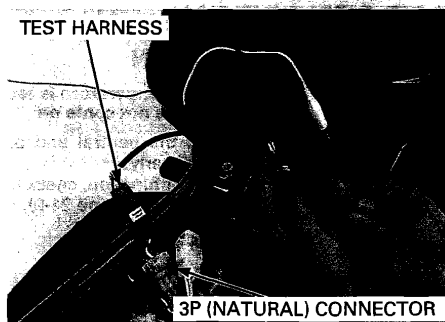

VS SENSOR REPLACEMENT

Remove the following:

- Seat (page 3-3)
- Left side cover (page 3-3)
- Left crankcase rear cover (page 3-5)

Disconnect the VS sensor 3P (Natural) connector.

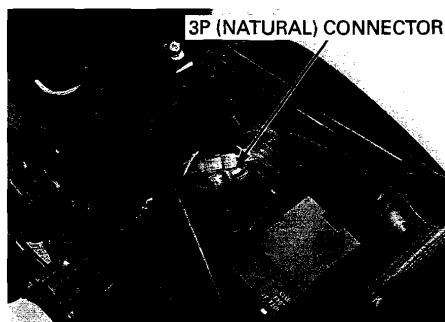

LIGHTS/METERS/SWITCHES

Release the VS sensor wire from the clamps and wire bands.

Remove the bolt and VS sensor from the crankcase.

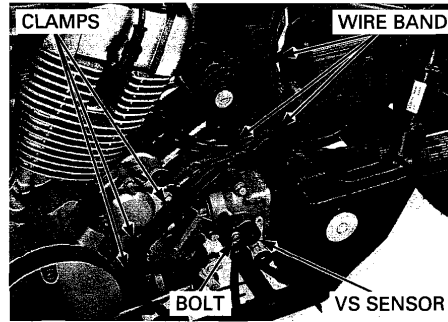

Coat a new O-ring with engine oil and install it into the VS sensor groove.

Route the VS sensor wire properly (page 1-22).

Install the VS sensor and mounting bolt.

Tighten the mounting bolt to the specified torque.

TORQUE: 9.8 N-m (1.0 kgf-m, 7.2 lbf-ft)

Install the removed parts in the reverse order of removal.

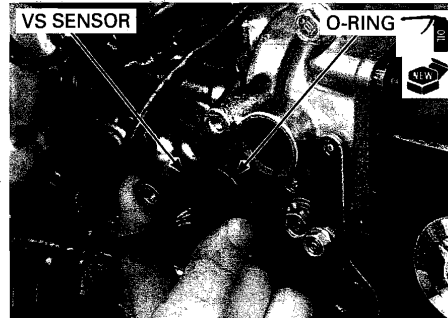

COOLANT TEMPERATURE INDICATOR/ECT SENSOR SWITCH

INSPECTION

The coolant temperature is too high, but the indicator does not come on

Check that the neutral and oil pressure indicators function properly.

If they do not function, check the power input line of the speedometer (page 21-9).

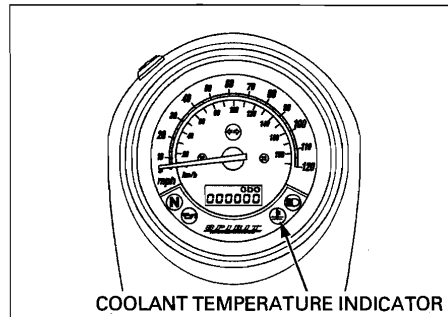

Remove the steering side covers (page 3-5).

Disconnect the ECT sensor switch connector and ground it.

Turn the ignition switch to ON and check the indicator.

- If the indicator comes on, inspect the ECT sensor switch.
- If the indicator does not come on, check for an open circuit in the Green/blue wire. If the wire is OK, replace the speedometer (page 21-10).

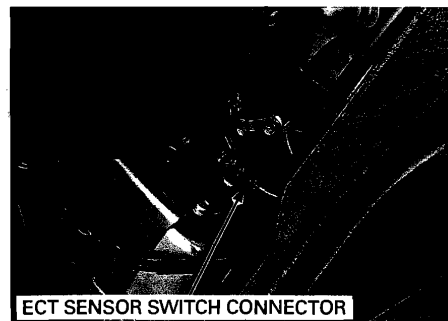

The coolant temperature is low but the indicator comes on.

Disconnect the ECT sensor switch connector. Turn the ignition switch to ON and check the indicator.

- If the indicator does not come on, inspect the ECT sensor switch.
- If the indicator comes on, check for a short circuit in the Green/blue wire. If the wire is OK, replace the speedometer (page 21-10).

ECT SENSOR SWITCH INSPECTION

Drain the coolant from the cooling system (page 7-7).

Remove the ECT sensor switch (page 21-13).

Wear insulated gloves and adequate eye protection. Keep flammable materials away from the burner.

Heat the coolant (1 : 1 mixture with distilled water) with an electric heating element.

Suspend the ECT sensor switch in heated coolant and check the continuity through the switch as the coolant heats up.

NOTE:

- Soak the ECT sensor switch in coolant up to its threads with at least 40 mm (1.6 in) from the bottom of the pan to the bottom of the switch.
- Keep temperature constant for 3 minutes before testing. A sudden change of temperature will result in incorrect readings. Do not let the thermometer or ECT sensor switch touch the pan.

Start to close (ON)	112 – 118°C (234 – 244°F)
Stop to open (OFF)	Below 108°C (226°F)

Replace the ECT sensor switch if it is out of specifications.

Install the ECT sensor switch (page 21-13).

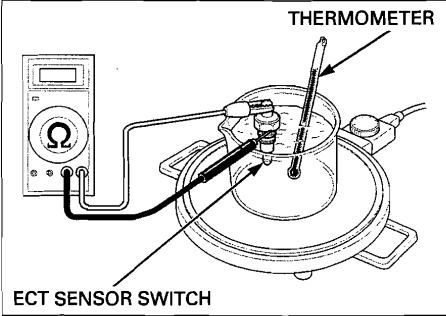

ECT SENSOR SWITCH REPLACEMENT

Drain the coolant from the cooling system (page 7-7).

Remove the steering side covers (page 3-5).

Disconnect the ECT sensor switch connector. Remove the ECT sensor switch from the thermostat housing.

Do not apply sealant to the thread head.

Apply sealant to the threads of a new ECT sensor switch.

Install and tighten the ECT sensor switch.

TORQUE: 7 N-m (0.7 kgf-m, 5.2 lbf-ft)

Fill and bleed the cooling system (page 7-7).

Install the steering side covers (page 3-5).

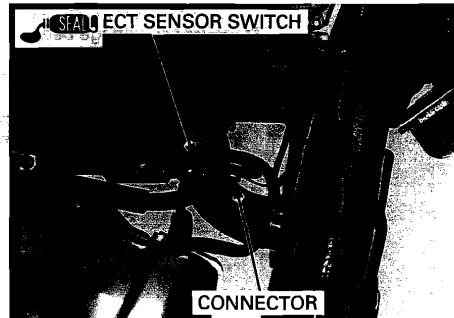

FAN MOTOR SWITCH

INSPECTION

The coolant temperature is low but the fan motor does not stop

Disconnect the connector from the fan motor switch and turn the ignition switch to ON.

- If the fan motor does not stop, check for a short circuit in the Black wire.
- If the fan motor stops, replace the fan motor switch.

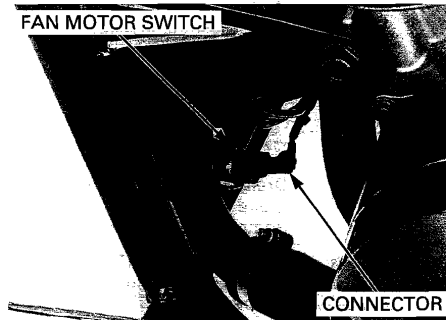

The coolant temperature indicator comes on but the fan motor does not start

Before testing, check for a blown sub fuse 20 A (FAN).

Disconnect the connector from the fan motor switch and ground it.

Turn the ignition switch to ON and check the fan motor.

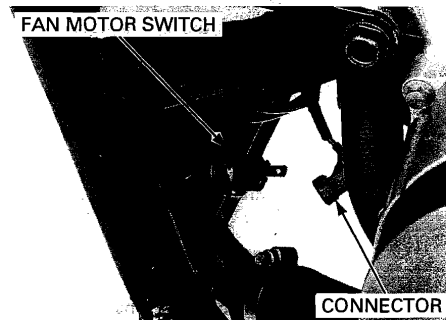

- If the motor starts, replace the fan motor switch.
- If the fan motor does not start, remove the steering side covers (page 3-5) and disconnect the fan motor 2P (Natural) connector.
Measure the voltage between the Black/blue wire and ground.
 - If there is battery voltage, replace the fan motor (page 7-11).
 - If there is no voltage, check for an open circuit in the Green and Black/blue wires.

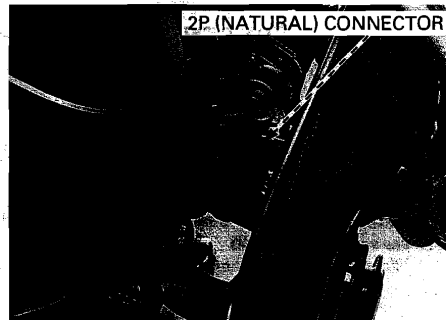

REPLACEMENT

Drain the coolant (page 7-7).
 Disconnect the connector from the fan motor switch.
 Remove the fan motor switch from the radiator.
 Install a new O-ring into the fan motor switch groove.
 Install and tighten the fan motor switch.
TORQUE: 18 N-m (1.8 kgf-m, 13 lbf-ft)
 Connect the connector to the fan motor switch.
 Fill and bleed the cooling system (page 7-7).

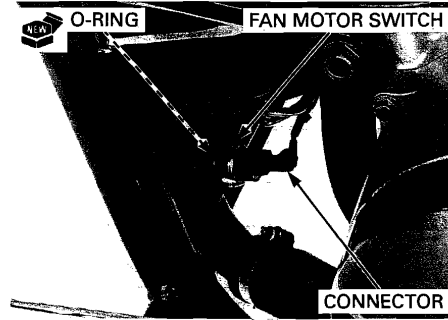

OIL PRESSURE INDICATOR

INSPECTION

Indicator does not come on with the ignition switch turned to ON

Check that the neutral and coolant temperature indicators function properly.
 If they do not function properly, check the power input line of the speedometer (page 21-9).

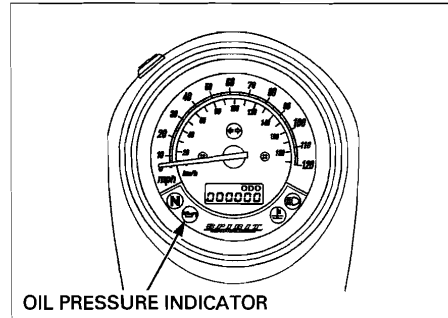

Remove the left crankcase rear cover (page 3-5).
 Remove the rubber cap, and disconnect the EOP switch wire by removing the terminal screw.
 Ground the wire terminal.
 Turn the ignition switch to ON and check the oil pressure indicator.

- If the indicator comes on, replace the EOP switch.
- If the indicator does not come on, check for an open circuit in the Blue/red wire. If the wire is OK, replace the speedometer (page 21-10).

Indicator stays on while the engine is running

Remove the rubber cap, and disconnect the EOP switch wire by removing the terminal screw.
 Check for continuity between the wire terminal and ground.

- If there is, check for a short circuit in the Blue/red wire.
- If there is no continuity, check the oil pressure (page 5-5).
 If the oil pressure is normal, replace the EOP switch.

After inspection, connect the EOP switch wire and tighten the terminal screw.

TORQUE: 1.9 N-m (0.2 kgf-m, 1.4 lbf-ft)

Install the rubber cap properly.
 Install the left crankcase rear cover (page 3-5).

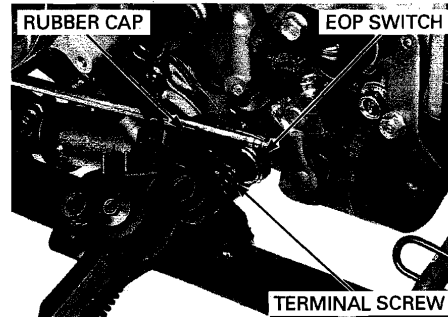

IGNITION SWITCH

INSPECTION

Remove the seat (page 3-3).

Disconnect the ignition switch 2P (Black) and 1P (Natural) connectors.

Check for continuity between the switch side connector terminals in each switch position. Continuity should exist between the color coded wires as shown in the chart.

	FAN	IG	BAT1
ON	○—○	○—○	○—○
OFF			
COLOR	Bw/O	R/BI	R

REMOVAL/INSTALLATION

Remove the following:

- Seat (page 3-3)
- Left side cover (page 3-3)

Disconnect the ignition switch 2P (Black) and 1P (Natural) connectors.

Release the wire from the wire band.

Remove the screw and ignition switch cover.

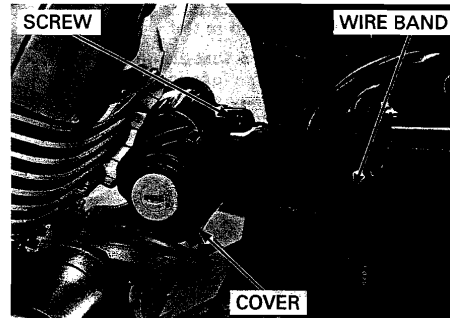
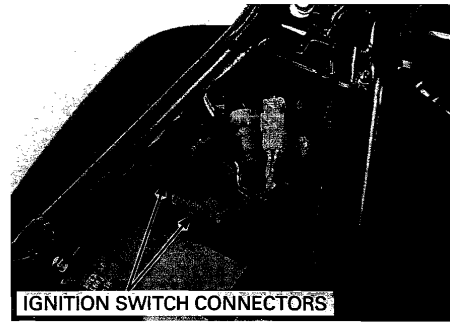

Remove the bolts and ignition switch assembly. Remove the bolts, ignition switch, collar and switch base from the stay.

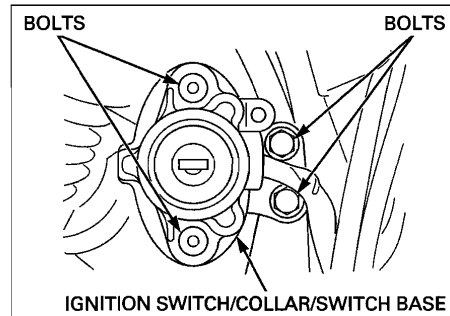

The ignition switch mounting bolt heads are broken by tighten them to the specified torque.

Install the switch base, ignition switch and collar to the stay.

Tighten new bolts to the specified torque.

TORQUE: 12 N·m (1.2 kgf·m, 9 lbf·ft)

Install the ignition switch assembly to the frame. Install the ignition switch cover and tighten the screw.

TORQUE: 1 N·m (0.1 kgf·m, 0.7 lbf·ft)

Route the ignition switch wire properly (page 1-22). Connect the ignition switch 2P (Black) and 1P (Natural) connectors.

Install the following:

- Left side cover (page 3-3)
- Seat (page 3-3)

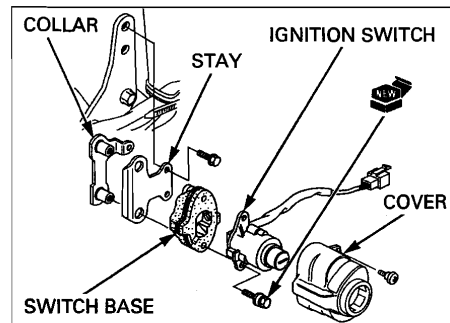

HANDLEBAR SWITCH

Remove the headlight unit (page 21-5).

Disconnect the following connectors:

- Left handlebar switch 6P (Blue)
- Left handlebar switch 6P (Black)
- Right handlebar switch 6P (Red)
- Dimmer switch 2P (Black)
- Turn signal light 3P (Light blue) and 3P (Orange)

Check for continuity between the connector terminals in each switch position. Continuity should exist between the color coded wires as shown in the charts.

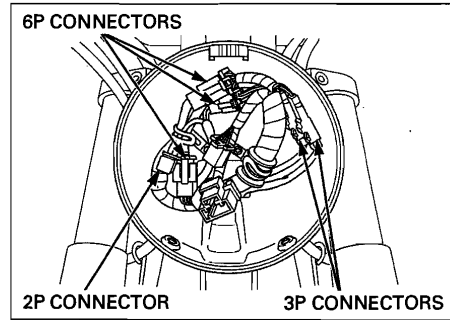

RIGHT HANDLEBAR SWITCH

ENGINE STOP SWITCH

	IG	BAT2
⊗		
⊙	○	○
COLOR	Bl/W	Bl/G

STARTER SWITCH

	ST	IG	BAT4	HL
FREE			○	○
PUSH	○	○		
COLOR	Y/R	Bl/W	Bl/R	Bu/W

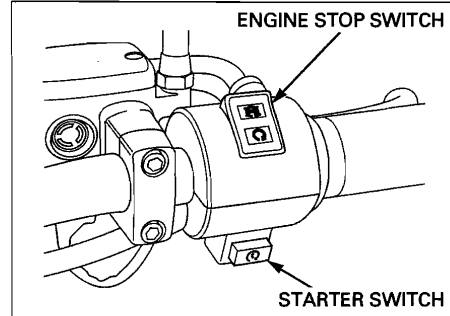

LEFT HANDLEBAR SWITCH

TURN SIGNAL SWITCH

	W	R	L	PO	PR	PL
R	○	○		○	○	○
N				○	○	○
L	○		○	○	○	
COLOR	Gr	Lb	O	Br	Lb/W	O/W

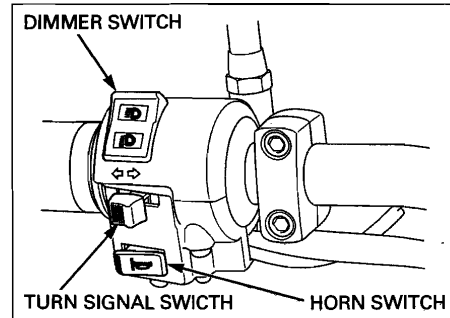

HORN SWITCH

	Ho	BAT3
FREE		
PUSH	○	○
COLOR	Lg	W/G

DIMMER SWITCH

	HL	Lo	Hi
Lo	○	○	
(N)	○	○	○
Hi	○		○
COLOR	Bu/W	W	Bu

BRAKE LIGHT SWITCH

FRONT

Disconnect the brake light switch connectors and check for continuity between the switch terminals.

There should be continuity with the brake lever squeezed and no continuity with the lever released.

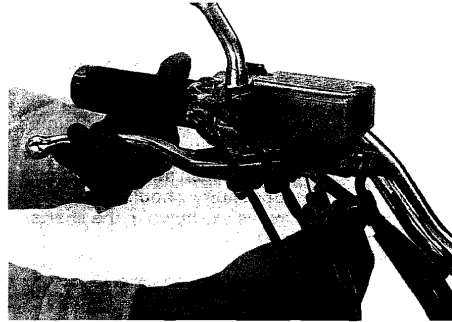

REAR

Remove the steering side covers (page 3-5).

Disconnect the rear brake light switch 3P (Light gray) connector and check for continuity between the switch side connector terminals.

There should be continuity with the brake pedal depressed and no continuity with the pedal released.

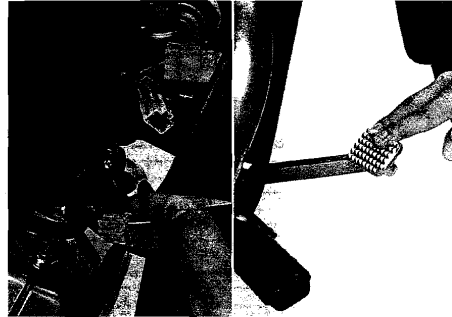

REAR BRAKE LIGHT SWITCH REMOVAL/INSTALLATION

Remove the steering side covers (page 3-5).

Remove the wire band and disconnect the rear brake light switch 3P (Light gray) connector.

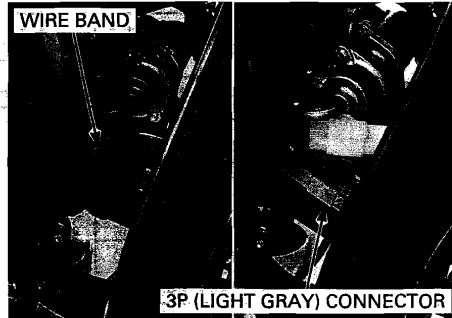

Unhook the return spring and remove the rear brake light switch.

Route the wire properly (page 1-22).

Installation is in the reverse order of removal. Adjust the rear brake light switch (page 4-22).

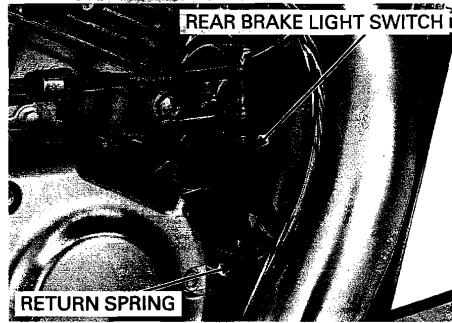

CLUTCH SWITCH

Disconnect the clutch switch wire connectors and check for continuity between the switch terminals.

There should be continuity with the clutch lever squeezed and no continuity with the lever released.

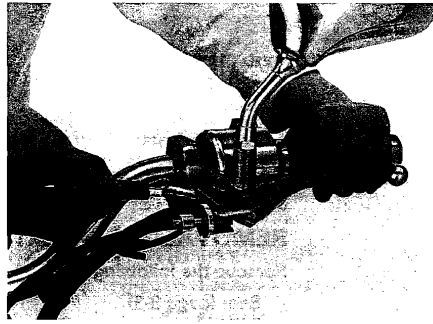

NEUTRAL SWITCH

Remove the left crankcase rear cover (page 3-5).

INSPECTION

Disconnect the neutral switch connector. Check for continuity between the switch terminal and engine ground.

There should be continuity when the transmission is in neutral, and no continuity when the transmission is in gear except neutral.

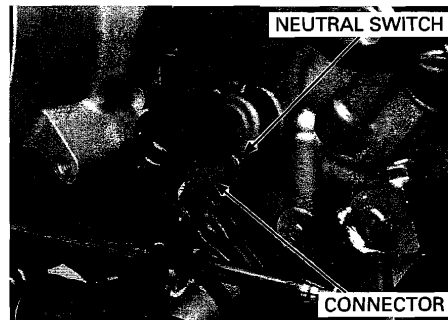

REPLACEMENT

Disconnect the neutral switch connector. Remove the neutral switch with the sealing washer from the crankcase.

Install the neutral switch with a new sealing washer and tighten it.

TORQUE: 12 N·m (1.2 kgf·m, 9 lbf·ft)

Connect the neutral switch connector.

Install the left crankcase rear cover (page 3-5).

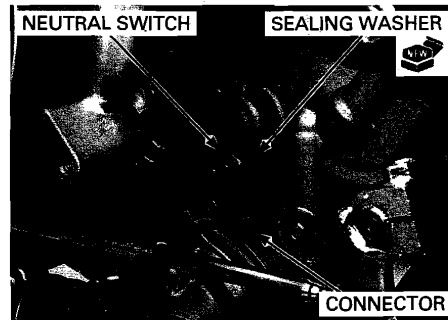

SIDESTAND SWITCH

INSPECTION

Remove the seat (page 3-3).

Disconnect the sidestand switch 2P (Green) connector.

Check for continuity between the switch side connector terminals.

There should be continuity with the sidestand retracted and no continuity with the sidestand lowered.

REMOVAL/INSTALLATION

Remove the following:

- Seat (page 3-3)
- Left side cover (page 3-3)
- Left crankcase rear cover (page 3-5)

Support the motorcycle securely.

Disconnect the sidestand switch 2P (Green) connector.

Release the sidestand switch wire from the wire bands and clamps.

2P (GREEN) CONNECTOR

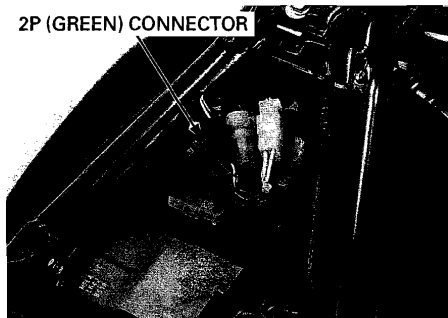

WIRE BANDS

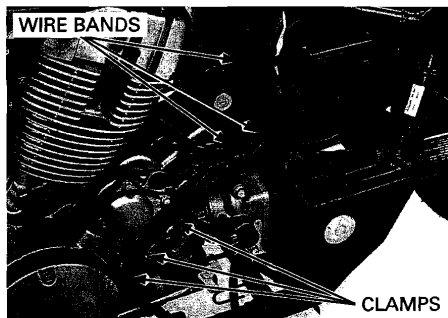

CLAMPS

BOLT

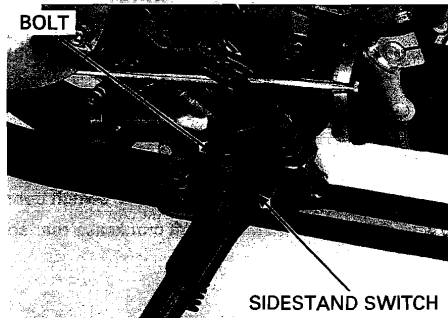

SIDESTAND SWITCH

Remove the bolt and sidestand switch.

Do not reuse the sidestand switch bolt.

Install the sidestand switch by aligning its pin with the sidestand hole and switch groove with the bracket pin.

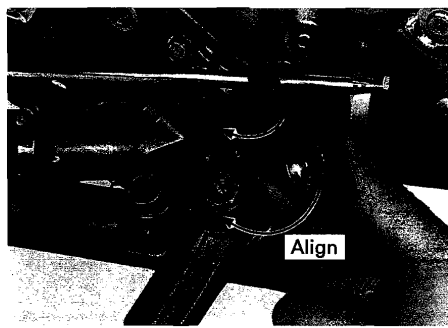

Align

Install a new sidestand switch bolt.
Tighten the bolt to the specified torque.

TORQUE: 10 N-m (1.0 kgf-m, 7 lbf-ft)

Route the sidestand switch wire properly (page 1-22).

Install the removed parts in the reverse order of removal.

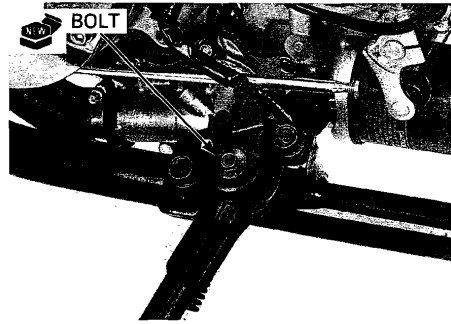

HORN

INSPECTION

Disconnect the connectors from the horn.
Connect a 12 V battery to the horn terminals.

The horn is normal if it sounds when the 12 V battery is connected across the horn terminals.

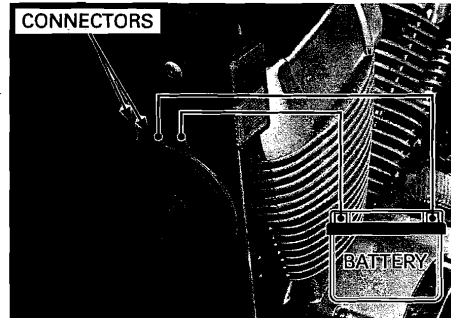

REMOVAL/INSTALLATION

Disconnect the connectors from the horn.

Remove the bolt and horn.

Install the horn to the frame, aligning its flat with the horn stay.

Install and tighten the bolt to the specified torque.

TORQUE: 21 N-m (2.1 kgf-m, 15 lbf-ft)

Connect the connectors.

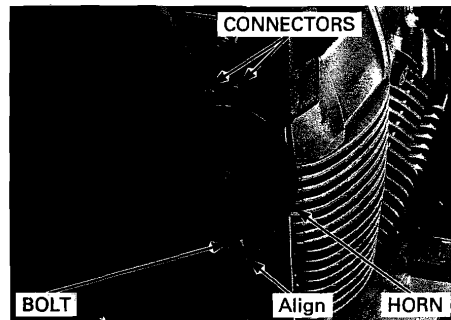

TURN SIGNAL RELAY

Turn signal light does not blink

Remove the right side cover (page 3-3).

Remove the turn signal relay from the stay.
Slide the rubber cap and disconnect the connector.
Connect the White/green and Gray wire terminals of the wire harness side connector with a jumper wire.
Turn the ignition switch to ON and check the turn signal lights by operating the turn signal switch.

- If the light does not come on, check for an open circuit in the White/green and Gray wires.
- If the light comes on, check the connector terminals for loose or poor contact.
If the connector terminals are OK, replace the turn signal relay.

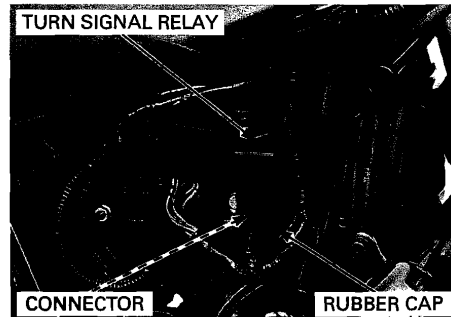

22. WIRING DIAGRAMS

**WIRING DIAGRAM
(49 states /Canada type) 22-3**

WIRING DIAGRAM (California type) 22-4

WIRING DIAGRAMS

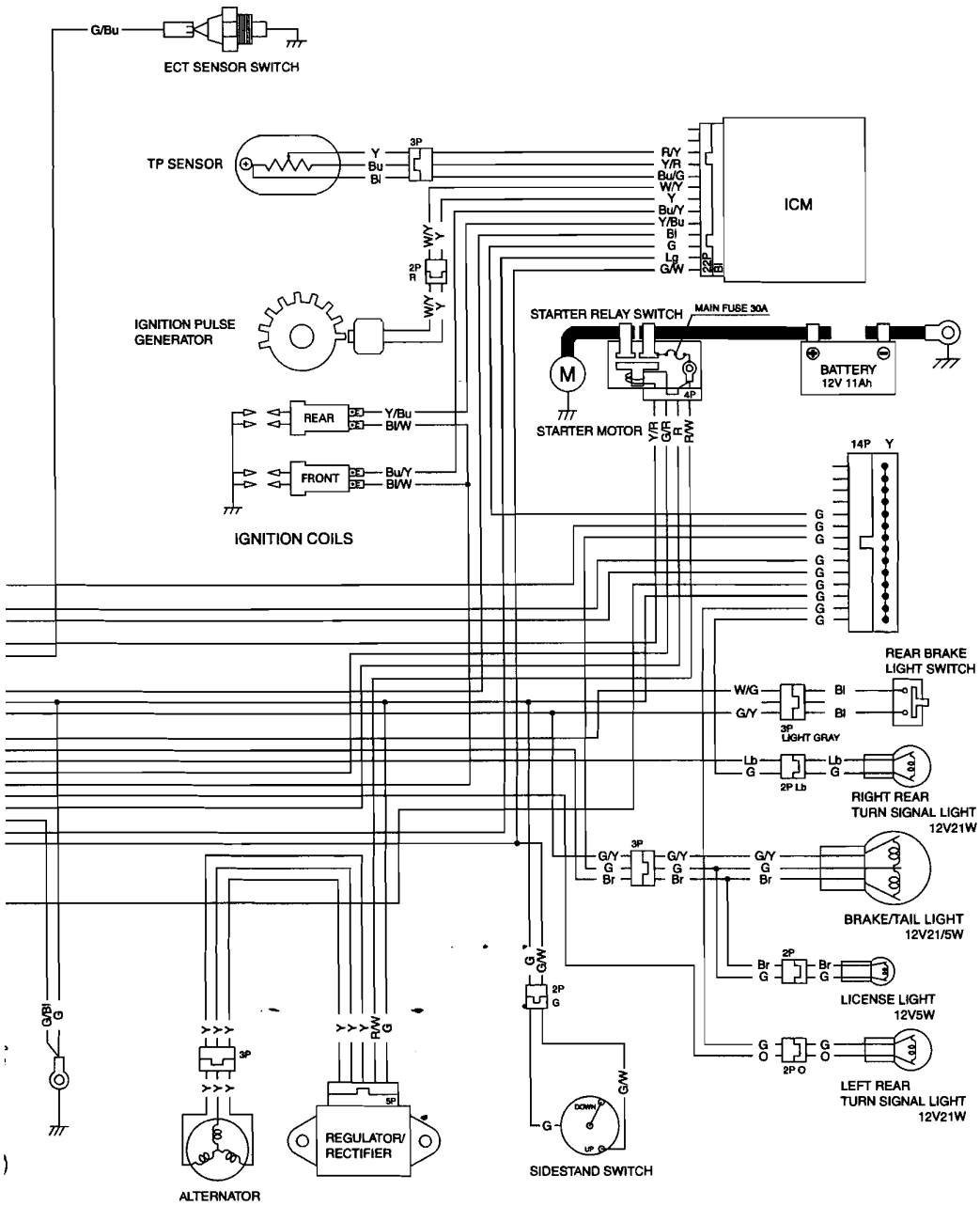

TRAL SWITCH

- | | | | |
|----|--------|----|-------------|
| BI | BLACK | Br | BROWN |
| Y | YELLOW | O | ORANGE |
| Bu | BLUE | Lb | LIGHT BLUE |
| G | GREEN | Lg | LIGHT GREEN |
| R | RED | P | PINK |
| W | WHITE | Gr | GRAY |

0030Z-MFE-6700

STARTER SWITCH

	ST	IG	BAT4	HL
FREE				
PUSH				

SWITCH

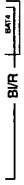

SIGNAL RELAY

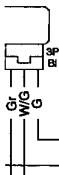

FUEL CUT-OFF SOLENOID VALVE

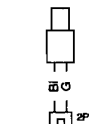

IGNITION SWITCH

	FAN	IG	BATT	KEY
1				KEY ON
2				KEY OFF

- BI BLACK
- Y YELLOW
- Bu BLUE
- G GREEN
- R RED
- W WHITE
- Br BROWN
- O ORANGE
- Lb LIGHT BLUE
- Lg LIGHT GREEN
- P PINK
- Gr GRAY

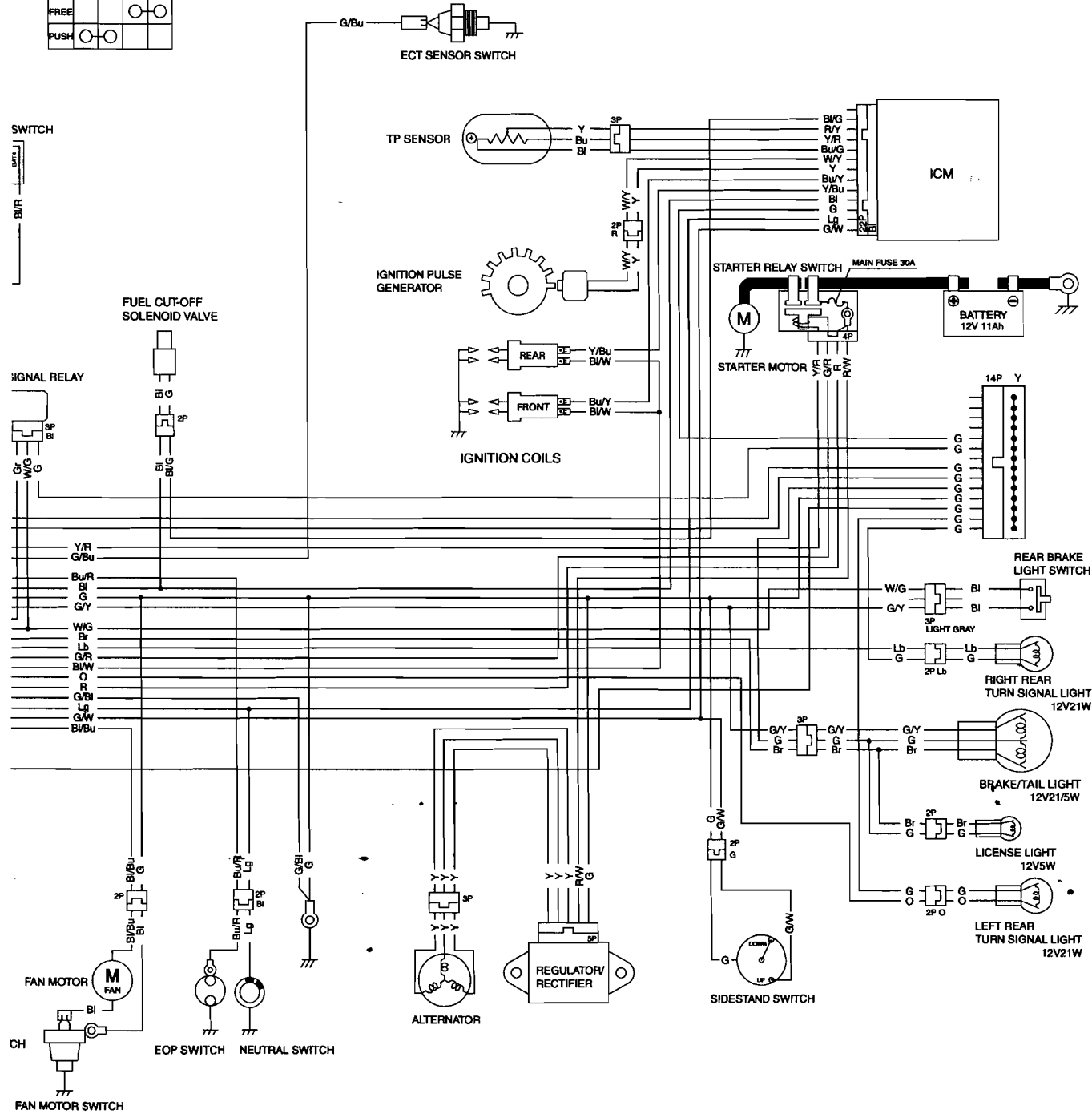

0030Z-MFE-7700

23. TROUBLESHOOTING

**ENGINE DOES NOT START OR IS HARD
TO START 23-2**

ENGINE LACKS POWER 23-3

**POOR PERFORMANCE AT LOW AND
IDLE SPEED 23-5**

**POOR PERFORMANCE AT
HIGH SPEED 23-6**

POOR HANDLING 23-7

ENGINE DOES NOT START OR IS HARD TO START

1. Fuel Line Inspection

Check fuel flow to carburetor.

Does fuel reach the carburetor?

- NO** – • Clogged fuel line and strainer
• Clogged fuel tank breather
• Sticking float valve
• Pinched fuel valve vacuum hose

YES – GO TO STEP 2.

2. Spark Plug Inspection

Remove and inspect spark plugs.

Is the spark plug wet?

- YES** – • Flooded carburetor
• SE valve ON position (open)
• Throttle valve open
• Dirty air cleaner

NO – GO TO STEP 3.

3. Spark Test

Perform spark test.

Is there weak or no spark?

- YES** – • Faulty spark plug
• Fouled spark plug
• Loose or disconnected ignition system wires
• Faulty ignition pulse generator
• Faulty ignition coil
• Faulty ICM
• Faulty engine stop switch

NO – GO TO STEP 4.

4. Cylinder Compression

Test cylinder compression.

Is the compression low?

- YES** – • Valve stuck open
• Worn cylinder and piston rings
• Damaged cylinder head gasket
• Seized valve
• Improper valve timing

NO – GO TO STEP 5.

5. Engine Starting Condition

Start engine by following normal procedure.

Does the engine start then stops?

- YES** – • Improper choke operation
• Incorrectly adjusted carburetor
• Leaking carburetor insulator or intake manifold
• Improper ignition timing (Faulty ICM, ignition pulse generator or TP sensor)
• Contaminated fuel

ENGINE LACKS POWER**1. Drive Train Inspection**

Raise wheel off the ground and spin it by hand.

Does the wheel spin freely?

- NO** - • Brake dragging
• Worn or damaged wheel bearings
• Final gear bearing damaged

YES - GO TO STEP 2.

2. Tire Pressure Inspection

Check tire pressure.

Are the tire pressures low?

- YES** - • Faulty tire valve
• Punctured tire

NO - GO TO STEP 3.

3. Clutch Inspection

Accelerate rapidly from low to second.

Does the engine speed change accordingly when the clutch is engaged?

- NO** - • Clutch slipping
• Worn clutch discs/plates
• Warped clutch discs/plates
• Weak clutch spring
• Additive in engine oil

YES - GO TO STEP 4.

4. Engine Performance Inspection

Accelerate lightly.

Does the engine speed increase?

- NO** - • SE valve ON position (open)
• Dirty air cleaner
• Restricted fuel flow
• Clogged muffler
• Clogged fuel tank breather
• Faulty TP sensor

YES - GO TO STEP 5.

5. Spark Plug Inspection

Remove and inspect spark plugs.

Is the spark plug fouled or discolored?

- NO** - • Plugs not serviced frequently enough
• Incorrect spark plug heat range
• Incorrect spark plug gap

YES - GO TO STEP 6.

6. Engine Oil Inspection

Check oil level and condition.

Is there correct level and good condition?

- NO** - • Oil level too high
• Oil level too low
• Contaminated oil

YES - GO TO STEP 7.

7. Ignition Timing Inspection

Check ignition timing.

Is the ignition timing correct?

- NO** – • Faulty ICM
• Faulty ignition pulse generator
• Faulty TP sensor

YES – GO TO STEP 8.

8. Cylinder Compression Inspection

Test cylinder compression.

Is the compression low?

- YES** – • Valve clearance too small
• Valve stuck open
• Worn cylinder and piston rings
• Damaged cylinder head gasket
• Improper valve timing

NO – GO TO STEP 9.

9. Carburetor Inspection

Check carburetor for clogs.

Is the carburetor clogged?

YES – Carburetor not serviced frequently enough.

NO – GO TO STEP 10.

10. Lubrication Inspection

Remove cylinder head cover and inspect lubrication.

Is the valve train lubricated properly?

- NO** – • Clogged oil passage
• Clogged oil orifice

YES – GO TO STEP 11.

11. Over Heating Inspection

Check for engine over heating.

Is the engine over heating?

- YES** – • Coolant level too low
• Fan motor not working
• Thermostat stuck closed
• Excessive carbon build-up in combustion chamber
• Use of poor quality fuel
• Wrong type of fuel
• Clutch slipping

NO – GO TO STEP 12.

12. Engine Knocking Inspection

Accelerate or run at high speed.

Is there knocking?

- YES** – • Worn piston and cylinder
• Wrong type of fuel
• Excessive carbon build-up in combustion chamber
• Ignition timing too advance (Faulty ICM)
• Lean fuel mixture
• Faulty TP sensor

NO – Engine does not knock.

POOR PERFORMANCE AT LOW AND IDLE SPEED**1. Pilot Screw Inspection**

Check carburetor pilot screw adjustment.

Is the adjustment correct?

NO - See page 6-25

YES - GO TO STEP 2.

2. Intake Air Leak Inspection

Check the carburetor insulator and intake manifold for leaks.

Are these leaks?

YES -

- Loose insulator bands
- Damaged insulator
- Faulty O-ring

NO - GO TO STEP 3.

3. Spark Test

Perform spark test.

Is there weak or intermittent spark?

YES -

- Faulty spark plug
- Fouled spark plug
- Loose or disconnected ignition system wires
- Faulty ignition pulse generator
- Faulty ignition coil
- Faulty engine stop switch
- Faulty ICM

NO - GO TO STEP 4.

4. Ignition Timing Inspection

Check ignition timing.

Is the ignition timing correct?

NO -

- Faulty ICM
- Faulty ignition pulse generator
- Faulty TP sensor

POOR PERFORMANCE AT HIGH SPEED

1. Fuel Line Inspection

Disconnect fuel line at carburetor.

Does fuel flow freely?

- NO** - • Restricted fuel line and strainer
• Restricted fuel tank breather
• Faulty fuel valve vacuum hose

YES - GO TO STEP 2.

2. Spark Plug Inspection

Remove and inspect the spark plug.

Is the spark plug in good condition?

- NO** - • Plug not serviced frequently enough
• Incorrect spark plug heat range
• Incorrect spark plug gap
• Faulty SE valve
• Air cleaner dirty

YES - GO TO STEP 3.

3. Carburetor Inspection

Check carburetor for clogging.

Is the carburetor clogged?

YES - Carburetor not serviced frequently enough.

NO - GO TO STEP 4.

4. Ignition Timing Inspection

Check ignition timing.

Is the ignition timing correct?

- NO** - • Faulty ICM
• Faulty ignition pulse generator
• Faulty TP sensor

YES - GO TO STEP 5.

5. Valve Timing Inspection

Check valve timing.

Is the valve timing correct?

NO - Cam sprockets not installed properly.

YES - GO TO STEP 6.

6. Valve Spring Inspection

Check valve springs.

Is the valve spring free length within specification?

NO - Faulty valve spring.

YES - GO TO STEP 7.

7. Camshaft Inspection

Remove and inspect the camshaft.

Is the cam lobe height within specification?

NO - Faulty camshaft.

YES - Camshaft is OK

POOR HANDLING**Steering is heavy**

- Steering top thread too tight
- Damaged steering head bearings
- Low tire pressure

Either wheel is wobbling

- Excessive wheel bearing play
- Bent rim
- Improperly installed wheel hub
- Excessively worn swingarm pivot bearings
- Bent frame

Motorcycle pulls to one side

- Front and rear wheels not aligned
- Bent fork
- Bent swingarm
- Bent axle
- Bent frame

AIR CLEANER.....	4-7	EMISSION CONTROL SYSTEMS.....	1-39
AIR CLEANER HOUSING.....	6-6	ENGINE & FRAME TORQUE VALUES.....	1-13
ALTERNATOR CHARGING COIL.....	18-9	ENGINE IDLE SPEED.....	4-15
ALTERNATOR/STARTER CLUTCH SPECIFICATIONS.....	1-9	ENGINE INSTALLATION.....	8-7
BATTERY.....	18-6	ENGINE OIL.....	4-12
BATTERY/CHARGING SYSTEM SPECIFICATIONS.....	1-12	ENGINE OIL FILTER.....	4-13
BRAKE FLUID.....	4-19	ENGINE REMOVAL.....	8-4
BRAKE FLUID REPLACEMENT/AIR BLEEDING.....	17-5	EVAP CONTROL SYSTEM (California type only) FUEL SYSTEM.....	6-30
BRAKE LIGHT SWITCH LIGHTS/METERS/SWITCHES.....	21-18	MAINTENANCE.....	4-17
MAINTENANCE.....	4-22	EXHAUST SYSTEM.....	3-8
BRAKE PAD/DISC.....	17-7	FAN MOTOR SWITCH.....	21-14
BRAKE PEDAL.....	16-17	FINAL DRIVE ASSEMBLY.....	14-17
BRAKE SHOES/PADS WEAR.....	4-20	FINAL DRIVE DISASSEMBLY/INSPECTION.....	14-8
BRAKE SYSTEM.....	4-20	FINAL DRIVE INSTALLATION.....	14-22
BRAKE/TAIL LIGHT.....	21-7	FINAL DRIVE OIL.....	4-18
CABLE & HARNESS ROUTING.....	1-22	FINAL DRIVE REMOVAL.....	14-7
CAMSHAFT INSTALLATION.....	9-26	FINAL DRIVE SPECIFICATIONS.....	1-10
CAMSHAFT REMOVAL.....	9-8	FLYWHEEL/STARTER CLUTCH.....	12-5
CARBURETOR ASSEMBLY.....	6-15	FORK.....	15-19
CARBURETOR DISASSEMBLY/INSPECTION.....	6-9	FRONT BRAKE CALIPER.....	17-13
CARBURETOR INSTALLATION.....	6-21	FRONT FENDER.....	3-6
CARBURETOR REMOVAL.....	6-7	FRONT WHEEL.....	15-13
CHARGING SYSTEM INSPECTION.....	18-7	FRONT WHEEL/SUSPENSION/STEERING SPECIFICATIONS.....	1-11
CHOKE OPERATION.....	4-6	FUEL LINE.....	4-5
CLUTCH INSTALLATION.....	11-18	FUEL SYSTEM SPECIFICATIONS.....	1-7
CLUTCH REMOVAL.....	11-7	FUEL TANK.....	3-4
CLUTCH SWITCH.....	21-19	GEARSHIFT LINKAGE.....	11-14
CLUTCH SYSTEM.....	4-22	GENERAL SPECIFICATIONS.....	1-5
CLUTCH/GEARSHIFT LINKAGE SPECIFICATIONS.....	1-9	HANDLEBAR.....	15-6
COMPONENT LOCATION		HANDLEBAR SWITCH.....	21-17
ALTERNATOR/STARTER CLUTCH.....	12-2	HEADLIGHT.....	21-5
CLUTCH/GEARSHIFT LINKAGE.....	11-2	HEADLIGHT AIM.....	4-22
CRANKSHAFT/TRANSMISSION.....	13-2	HIGH ALTITUDE ADJUSTMENT.....	6-26
CYLINDER HEAD/VALVE.....	9-2	HORN.....	21-21
CYLINDER/PISTON.....	10-2	HYDRAULIC BRAKE SPECIFICATIONS.....	1-11
ENGINE REMOVAL/INSTALLATION.....	8-2	ICM.....	19-9
FINAL DRIVE.....	14-2	IGNITION COIL.....	19-8
FRONT WHEEL/SUSPENSION/STEERING.....	15-2	IGNITION SWITCH.....	21-16
FUEL SYSTEM.....	6-2	IGNITION SYSTEM INSPECTION.....	19-5
HYDRAULIC BRAKE.....	17-2	IGNITION SYSTEM SPECIFICATIONS.....	1-12
REAR WHEEL/BRAKE/SUSPENSION.....	16-2	IGNITION TIMING.....	19-9
COOLANT REPLACEMENT.....	7-6	INTAKE MANIFOLD.....	6-23
COOLANT TEMPERATURE INDICATOR/ ECT SENSOR SWITCH.....	21-12	LEFT CRANKCASE REAR COVER.....	3-5
COOLING SYSTEM.....	4-15	LICENSE LIGHT.....	21-8
COOLING SYSTEM SPECIFICATIONS.....	1-7	LIGHTS/METERS/SWITCHES SPECIFICATIONS.....	1-12
CRANKCASE ASSEMBLY.....	13-49	LUBRICATION & SEAL POINTS.....	1-19
CRANKCASE BEARING REPLACEMENT.....	13-47	LUBRICATION SYSTEM DIAGRAM.....	5-2
CRANKCASE BREATHER.....	4-8	LUBRICATION SYSTEM SPECIFICATIONS.....	1-7
CRANKCASE SEPARATION.....	13-9	MAIN JOURNAL BEARING.....	13-16
CRANKPIN BEARING.....	13-13	MAINTENANCE SCHEDULE.....	4-4
CRANKSHAFT/CONNECTING ROD.....	13-10	MASTER CYLINDER.....	17-8
CRANKSHAFT/TRANSMISSION SPECIFICATIONS.....	1-10	MODEL IDENTIFICATION.....	1-2
CYLINDER COMPRESSION.....	9-6	NEUTRAL SWITCH.....	21-19
CYLINDER HEAD ASSEMBLY.....	9-22	NUTS, BOLTS, FASTENERS.....	4-24
CYLINDER HEAD COVER INSTALLATION.....	9-31	OIL PRESSURE INDICATOR.....	21-15
CYLINDER HEAD COVER REMOVAL.....	9-6	OIL PRESSURE INSPECTION.....	5-5
CYLINDER HEAD DISASSEMBLY.....	9-15	OIL PUMP.....	5-6
CYLINDER HEAD INSTALLATION.....	9-24	OUTPUT GEAR.....	13-28
CYLINDER HEAD REMOVAL.....	9-14	OXIDATION CATALYTIC CONVERTER PROTECTION FROM UNBURNED GASOLINE (California type only).....	2-2
CYLINDER HEAD/VALVE SPECIFICATIONS.....	1-8	PILOT SCREW ADJUSTMENT.....	6-25
CYLINDER/PISTON INSTALLATION.....	10-9	PRIMARY DRIVE GEAR.....	11-12
CYLINDER/PISTON REMOVAL.....	10-4	RADIATOR COOLANT.....	4-15
CYLINDER/PISTON SPECIFICATIONS.....	1-8	RADIATOR RESERVE TANK.....	7-17
DIODE.....	20-16	RADIATOR/COOLING FAN.....	7-11
ELECTRIC STARTER SPECIFICATIONS.....	1-12	REAR BRAKE.....	16-14

INDEX

REAR FENDER.....	3-6	SYSTEM DIAGRAM	
REAR WHEEL.....	16-6	BATTERY/CHARGING SYSTEM.....	18-2
REAR WHEEL/BRAKE/SUSPENSION		ELECTRIC STARTER.....	20-2
SPECIFICATIONS.....	1-11	IGNITION SYSTEM.....	19-2
REGULATOR/RECTIFIER.....	18-8	SYSTEM FLOW PATTERN.....	7-2
RIGHT CRANKCASE COVER INSTALLATION.....	11-21	SYSTEM LOCATION	
RIGHT CRANKCASE COVER REMOVAL.....	11-5	BATTERY/CHARGING SYSTEM.....	18-2
SEAT.....	3-3	ELECTRIC STARTER.....	20-2
SECONDARY AIR SUPPLY SYSTEM		IGNITION SYSTEM.....	19-2
FUEL SYSTEM.....	6-28	LIGHTS/METERS/SWITCHES.....	21-2
MAINTENANCE.....	4-16	SYSTEM TESTING.....	7-5
SERVICE INFORMATION		THERMOSTAT.....	7-8
ALTERNATOR/STARTER CLUTCH.....	12-3	THERMOSTAT HOUSING.....	7-9
BATTERY/CHARGING SYSTEM.....	18-3	THROTTLE OPERATION.....	4-5
CLUTCH/GEARSHIFT LINKAGE.....	11-3	TP SENSOR.....	19-10
COOLING SYSTEM.....	7-3	TRANSMISSION.....	13-20
CRANKSHAFT/TRANSMISSION.....	13-3	TROUBLESHOOTING	
CYLINDER HEAD/VALVE.....	9-3	ALTERNATOR/STARTER CLUTCH.....	12-3
CYLINDER/PISTON.....	10-3	BATTERY/CHARGING SYSTEM.....	18-5
ELECTRIC STARTER.....	20-3	CLUTCH/GEARSHIFT LINKAGE.....	11-4
ENGINE REMOVAL/INSTALLATION.....	8-3	COOLING SYSTEM.....	7-4
FINAL DRIVE.....	14-3	CRANKSHAFT/TRANSMISSION.....	13-8
FRAME/BODY PANELS/EXHAUST SYSTEM.....	3-2	CYLINDER HEAD/VALVE.....	9-5
FRONT WHEEL/SUSPENSION/STEERING.....	15-3	CYLINDER/PISTON.....	10-3
FUEL SYSTEM.....	6-3	ELECTRIC STARTER.....	20-4
HYDRAULIC BRAKE.....	17-3	ENGINE DOES NOT START OR IS HARD	
IGNITION SYSTEM.....	19-3	TO START.....	23-2
LIGHTS/METERS/SWITCHES.....	21-3	ENGINE LACKS POWER.....	23-3
LUBRICATION SYSTEM.....	5-3	FINAL DRIVE.....	14-6
MAINTENANCE.....	4-2	FRAME/BODY PANELS/EXHAUST SYSTEM.....	3-2
REAR WHEEL/BRAKE/SUSPENSION.....	16-3	FRONT WHEEL/SUSPENSION/STEERING.....	15-5
SERVICE RULES.....	1-2	FUEL SYSTEM.....	6-4
SHOCK ABSORBER.....	16-21	HYDRAULIC BRAKE.....	17-4
SIDE COVER.....	3-3	IGNITION SYSTEM.....	19-4
SIDESTAND.....	4-23	LUBRICATION SYSTEM.....	5-4
SIDESTAND SWITCH.....	21-20	POOR HANDLING.....	23-7
SPARK PLUG.....	4-9	POOR PERFORMANCE AT HIGH SPEED.....	23-6
SPEEDOMETER/VISOR SENSOR.....	21-9	POOR PERFORMANCE AT LOW AND	
STANDARD TORQUE VALUES.....	1-13	IDLE SPEED.....	23-5
STARTER MOTOR.....	20-6	REAR WHEEL/BRAKE/SUSPENSION.....	16-5
STARTER RELAY SWITCH.....	20-15	TURN SIGNAL LIGHT.....	21-6
STATOR INSTALLATION.....	12-11	TURN SIGNAL RELAY.....	21-21
STATOR REMOVAL.....	12-4	VALVE CLEARANCE.....	4-10
STEERING HEAD BEARINGS.....	4-26	VALVE GUIDE REPLACEMENT.....	9-18
STEERING SIDE COVER.....	3-5	VALVE SEAT INSPECTION/REFACING.....	9-19
STEERING STEM.....	15-28	WATER PUMP.....	7-16
SUB AIR CLEANER.....	4-8	WHEELS/TIRES.....	4-25
SUSPENSION.....	4-24	WIRING DIAGRAM	
SWINGARM.....	16-22	49 states/Canada type.....	22-3
		California type.....	22-4